

CHEVROLET

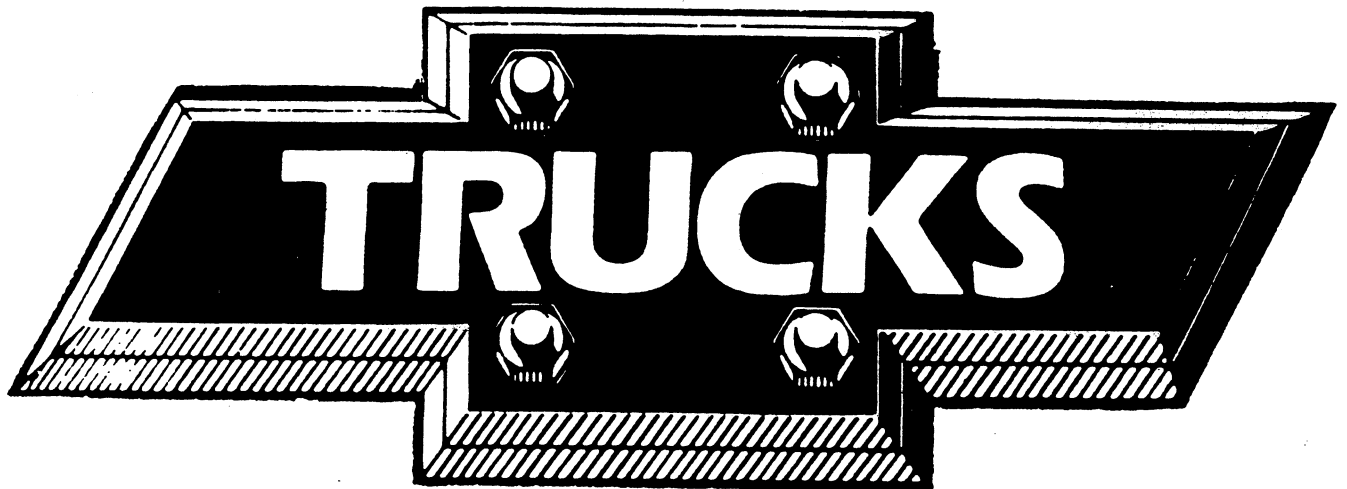

1988

C/K PICKUP

PICKUP MODEL SELECTOR

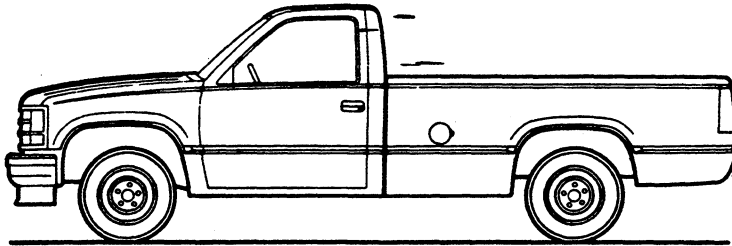

FLEETSIDE/WIDESIDE

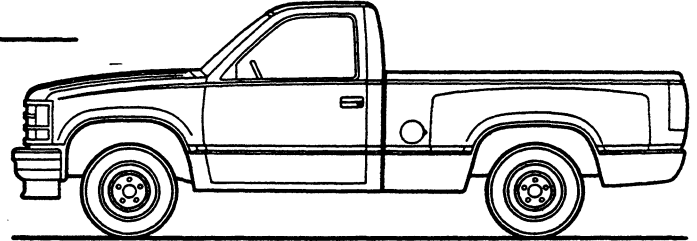

SPORTSIDE

REGULAR CAB

SERIES	MODEL NUMBER		BODY ORDERING CODE			
			GASOLINE MODELS		DIESEL MODELS	
	6½' BOX	8' BOX	FLEETSIDE/ WIDESIDE	SPORTSIDE	FLEETSIDE/ WIDESIDE	SPORTSIDE
C1500	C10703	C10903	E63	*E62	E63/B3J	—
C2500	—	C20903	E63	—	E63/B3J	—
C3500	—	C30903	E63	—	E63/B3J	—
K1500 (4X4)	K10703	K10903	E63	*E62	E63/B3J	—
K2500 (4X4)	—	K20903	E63	—	E63/B3J	—
K3500 (4X4)	—	K30903	E63	—	E63/B3J	—

*Available on C/K 10703 models only.

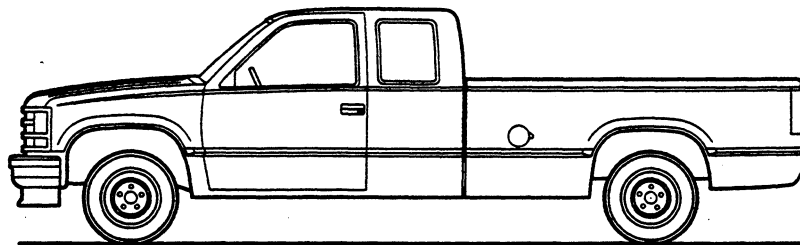

EXTENDED CAB

SERIES	MODEL NUMBER	BODY ORDERING CODE 8' FLEETSIDE/WIDESIDE BOX	
		GASOLINE MODELS	DIESEL MODELS
C1500	C10953	E63	E63/B3J
C2500	C20953	E63	E63/B3J
C3500	C30953	E63	E63/B3J
K1500 (4X4)	K10953	E63	E63/B3J
K2500 (4X4)	K20953	E63	E63/B3J
K3500 (4X4)	K30953	E63	E63/B3J

GASOLINE**C/K PICKUP—2-Wheel Drive****C1500 REGULAR CABS
C1500 EXTENDED CABS****STANDARD SPECIFICATIONS**

(See Gray Tab Section for Specification Details)

Series	C1500 Regular Cab	C1500 Extended Cab
Engine	4.3 Liter, 262 EFI V6	
Base Equip.	11"; 124 sq. in.	
Clutch	Oiled-paper Element	
Air Filter	Throwaway Type	
Oil Filter	Single; Aluminized	
Exhaust System	See Engine & Cooling Section for specific model applications	
Emission Control Systems		
Suspension, Front	Independent; Coil Springs	
Capacity	2950 lb.	3600 lb.
Springs @ Ground	1475-1800 lb. ea.	1750-1800 lb. ea.
Shock Absorbers	25mm dia.	
Suspension, Rear	Salisbury Axle; Hypoid Drive; Two-stage Multi-leaf Springs	
Axle Capacity	3750 lb.	
Axle Ratio	2.73	
Springs @ Ground	1875 lb. ea.	
Shock Absorbers	25mm dia.	
Brakes	Hydraulic; Self-adjusting	
Front	Disc; 11.57" Rotor	
Rear	Drum; 10" x 2.25"	
Booster	Single Diaphragm	Dual Diaphragm
Parking	Cable to Rear Wheels	
Electrical	12 Volt; Negative Ground	
Battery—Freedom Type	525 CCA♦ @ 0°F.	
—Reserve Capacity	90 min. @ 80°F.	
Delcotron Generator	85 amp.	
Frame	Carbon Steel; 36,-39,000 psi	
Section Modulus	2.70	3.42
Fuel Tank (nominal capacity)	25 gal.	
Steering Gear Type	Integral Power	
Transmission	5-Speed Manual (w/Overdrive)	
Shift Location	Floor	
Tires	(5) P205/75R15	(5) P235/75R15
Wheels	(5) Disc	(5) Disc
Size	15" x 6"	15" x 7"

♦CCA-Cold Cranking Amps

C/K PICKUP—2-Wheel Drive

DIESEL

**C1500 REGULAR CABS
C1500 EXTENDED CABS**

STANDARD SPECIFICATIONS

(See Gray Tab Section for Specification Details)

Series	▲C1500 Regular Cab	C1500 Extended Cab
Engine	6.2 Liter, 379 Cu. In. V8 Diesel	
Base Equip.	12"; 150 sq. in.	
Clutch	Poly-wrapped, Oiled-paper Element	
Air Filter	Throwaway Type	
Oil Filter	Single; Aluminized	
Exhaust System	See Engine & Cooling Section for specific model applications	
Emission Control Systems		
Suspension, Front	Independent; Coil Springs	
Capacity	2950 lb.	3600 lb.
Springs @ Ground	1500 lb. ea.	1800 lb. ea.
Shock Absorbers	25mm dia.	
Suspension, Rear	Salisbury Axle; Hypoid Drive; Two-stage Multi-leaf Springs	
Axle Capacity	3750 lb.	
Axle Ratio	3.08	
Springs @ Ground	1875 lb. ea.	
Shock Absorbers	25mm dia.	
Brakes	Hydraulic, Self-adjusting	
Front	Disc; 11.86" Rotor	
Rear	Drum; 11" x 2"	
Booster	Dual Diaphragm	
Parking	Cable to Rear Wheels	
Electrical	12 Volt; Negative Ground	
Battery—Freedom Type	Two; 540 CCA♦ ea. @ 0°F.	
—Reserve Capacity	115 min. ea. @ 80°F	
Delcotron Generator	66 amp.	
Engine Block Heater	600 watts, 120 volts	
Frame	Carbon Steel; 36,-39,000 psi	
Section Modulus	2.70	3.42
Fuel Tank (nominal capacity)	25 gal.	
Steering Gear Type	Integral Power	
Transmission	4-Speed Manual (SM 465)	
Shift Location	Floor	
Tires	(5) P235/75R15	
Wheels	(5) Disc	
Size	15" x 6"	

▲Available on C10903 model only.

♦CCA-Cold Cranking Amps

GASOLINE

C/K PICKUP—2-Wheel Drive

**C2500 REGULAR CABS
C2500 EXTENDED CABS**

STANDARD SPECIFICATIONS

(See Gray Tab Section for Specification Details)

Series	C2500 Regular Cab	C2500 Extended Cab
Engine	4.3 Liter, 262 EFI V6 11"; 124 sq. in. Oiled-paper Element Throwaway Type Single; Aluminized See Engine & Cooling Section for specific model applications	
Base Equip.		
Clutch		
Air Filter		
Oil Filter		
Exhaust System		
Emission Control Systems	See Engine & Cooling Section for specific model applications	
Suspension, Front	Independent; Coil Springs	
Capacity	3150 lb.	3600 lb.
Springs @ Ground	1700-1900 lb. ea.	
Shock Absorbers	32mm dia.	
Suspension, Rear	Salisbury Axle; Hypoid Drive; Two-stage Multi-leaf Springs	
Axle Capacity	4800 lb.	
Axle Ratio	3.42	
Springs @ Ground	2400 lb. ea.	
Shock Absorbers	32mm dia.	
Brakes	Hydraulic, Self-adjusting	
Front	Disc; 11.57" Rotor	
Rear	Drum; 11.15" x 2.75"	
Booster	Dual Diaphragm	
Parking	Cable to Rear Wheels	
Electrical	12 Volt; Negative Ground	
Battery—Freedom Type	525 CCA♦ @ 0°F.	
—Reserve Capacity	90 min. @ 80°F.	
Delcotron Generator	85 amp.	
Frame	Carbon Steel; 36,-39,000 psi	
Section Modulus	2.70	3.42
Fuel Tank (nominal capacity)	25 gal.	
Steering Gear Type	Integral Power	
Transmission	5-Speed Manual (w/Overdrive)	
Shift Location	Floor	
Tires	(4) LT225/75R16D (8PR)	
Wheels	(4) Disc	
Size	16" x 6.5"	

♦CCA-Cold Cranking Amps

C/K PICKUP—2-Wheel Drive

DIESEL

C2500 REGULAR CABS C2500 EXTENDED CABS

STANDARD SPECIFICATIONS

(See Gray Tab Section for Specification Details)

Series	C2500 Regular Cab	C2500 Extended Cab
Engine	6.2 Liter, 379 Cu. In. V8 Diesel	
Base Equip.	12"; 150 sq. in.	
Clutch	Poly-wrapped, Oiled-paper Element	
Air Filter	Throwaway Type	
Oil Filter	Standard	
Oil Cooler	Single; Aluminized	
Exhaust System	See Engine & Cooling Section for specific model applications	
Emission Control Systems		
Suspension, Front	Independent; Coil Springs	
Capacity	3400 lb.	3600 lb.
Springs @ Ground	1700-1800 lb. ea.	
Shock Absorbers	32mm dia.	
Suspension, Rear	Salisbury Axle; Hypoid Drive; Two-stage Multi-leaf Springs	
Axle Capacity	4800 lb.	
Axle Ratio	3.42	
Springs, Main @ Ground	2400 lb. ea.	
Shock Absorbers	32mm dia.	
Brakes	Hydraulic, Self-adjusting	
Front	Disc; 11.57" Rotor	
Rear	Drum; 11.15" x 2.75"	
Booster	Hydraulic Power	
Parking	Cable to Rear Wheels	
Electrical	12 Volt; Negative Ground	
Battery—Freedom Type	Two: 570 CCA♦ ea. @ 0°F.	
—Reserve Capacity	90 min. ea. @ 80°F.	
Delcotron Generator	85 amp.	
Engine Block Heater	600 watts, 120 volts	
Frame	Carbon Steel; 36,-39,000 psi	
Section Modulus	2.70	3.42
Fuel Tank (nominal capacity)	25 gal.	
Steering Gear Type	Integral Power	
Transmission	4-Speed Manual (SM 465)	
Shift Location	Floor	
Tires	(4) LT 225/75R16D (8PR)	
Wheels	(4) Disc	
Size	16" x 6.5"	

♦CCA-Cold Cranking Amps

GASOLINE

C/K PICKUP—2-Wheel Drive

**C3500 REGULAR CABS
C3500 EXTENDED CABS**

STANDARD SPECIFICATIONS

(See Gray Tab Section for Specification Details)

Series	C3500 Regular Cab	C3500 Extended Cab
Engine		
Base Equip.	5.7 Liter, 350 EFI V8	
Clutch	12"; 150 sq. in.	
Air Filter	Oiled-paper Element	
Oil Filter	Throwaway Type	
Exhaust System	Single; Stainless Steel	
Emission Control Systems	See Engine & Cooling Section for specific model applications	
Suspension, Front	Independent; Coil Springs	
Capacity	3800 lb.	
Springs @ Ground	1800-1900 lb. ea.	
Shock Absorbers	32mm	
Suspension, Rear	Salisbury Axle; Hypoid Drive; Two-stage Multi-leaf Springs	
Axle Capacity	6000 lb.	
Axle Ratio	3.42	
Springs @ Ground	3000 lb. ea.	
Shock Absorbers	32mm dia.	
Brakes	Hydraulic, Self-adjusting	
Front	Disc; 12.5" rotor	
Rear	Drum; 13" x 2.5"	
Booster	Dual Diaphragm	
Parking	Cable to Rear Wheels	
Electrical	12 Volt; Negative Ground	
Battery—Freedom Type	525 CCA♦ ea. @ 0°F.	
—Reserve Capacity	90 min. @ 80°F.	
Delcotron Generator	85 amp.	
Frame	Carbon Steel; 36,-39,000 psi	
Section Modulus	5.38	6.21
Fuel Tank (Nominal Capacity)	25 gal.	
Steering Gear Type	Integral Power	
Transmission	4-Speed Manual (SM 465)	
Shift Location	Floor	
Tires	(4) LT 245/75R16E (10PR)	
Wheels	(4) Disc	
Size	16" x 6.5"	

♦CCA-Cold Cranking Amps

C/K PICKUP—2-Wheel Drive

DIESEL

**C3500 REGULAR CABS
C3500 EXTENDED CABS**

STANDARD SPECIFICATIONS

(See Gray Tab Section for Specification Details)

Series	C3500 Regular Cab	C3500 Extended Cab
Engine	6.2 Liter, 379 Cu. In. V8 Diesel	
Base Equip.	12"; 150 sq. in.	
Clutch	Poly-wrapped, Oiled-paper Element	
Air Filter	Throwaway type	
Oil Filter	Standard	
Oil Cooler	Single; Aluminized	
Exhaust System	See Engine & Cooling Section for specific model applications	
Emission Control Systems		
Suspension, Front	Independent; Coil Springs	
Capacity	3800 lb.	
Springs @ Ground	1900 lb. ea.	
Shock Absorbers	32mm	
Suspension, Rear	Salisbury Axle; Hypoid Drive; Two-stage Multi-leaf Springs	
Axle Capacity	6000 lb.	
Axle Ratio	3.73	
Springs @ Ground	3000 lb. ea.	
Shock Absorbers	32mm dia.	
Brakes	Hydraulic, Self-adjusting	
Front	Disc; 12.5" rotor	
Rear	Drum; 13" x 2.5"	
Booster	Hydraulic Power	
Parking	Cable to Rear Wheels	
Electrical	12 Volt; Negative Ground	
Battery—Freedom Type	Two; 570 CCA♦ ea. @ 0°F.	
—Reserve Capacity	90 min. @ 80°F.	
Delcotron Generator	85 amp.	
Engine Block Heater	600 watts, 120 volts	
Frame	Carbon Steel; 36,-39,000 psi	
Section Modulus	5.38	6.21
Fuel Tank (Nominal Capacity)	25 gal.	
Steering Gear Type	Integral Power	
Transmission	4-Speed Manual (SM 465)	
Shift Location	Floor	
Tires	(4) LT245/75R16E (10PR)	
Wheels	(4) Disc	
Size	16" x 6.5"	

♦CCA-Cold Cranking Amps

GASOLINE

C/K PICKUP—4-Wheel Drive

**K1500 REGULAR CABS
K1500 EXTENDED CABS**

STANDARD SPECIFICATIONS

(See Gray Tab Section for Specification Details)

Series	K1500 Regular Cab	K1500 Extended Cab
Engine		
Base Equip.	4.3 Liter, 262 EFI V6	
Clutch	11"; 124 sq. in.	
Air Filter	Oiled-paper Element	
Oil Filter	Throwaway Type	
Exhaust System	Single; Aluminized	
Emission Control Systems	See Engine & Cooling Section for specific model applications	
Suspension, Front	Independent; Torsion Bars	
Capacity—117.5" WB	3350 lb.	—
—131.5" WB	3450 lb.	—
—155.5" WB	—	3925 lb.
Axle Ratio	3.42	
Springs @ Ground	1800-1963 lb. ea.	
Shock Absorbers	25mm dia.	
Suspension, Rear	Salisbury Axle; Hypoid Drive; Two-stage Multi-leaf Springs	
Axle Capacity	3750 lb.	
Axle Ratio	3.42	
Springs @ Ground	1875 lb. ea.	
Shock Absorbers	25mm dia.	
Brakes	Hydraulic; Self-adjusting	
Front	Disc; 11.57" Rotor	
Rear	Drum; 10" x 2.25"	
Booster	Single Diaphragm	Dual Diaphragm
Parking	Cable to Rear Wheels	
Electrical	12 Volt; Negative Ground	
Battery—Freedom Type	525 CCA♦ @ 0°F.	
—Reserve Capacity	90 min. @ 80°F.	
Delcotron Generator	85 amp.	
Frame	Carbon Steel; 36,-39,000 psi	
Section Modulus	3.46	4.30
Fuel Tank (nominal capacity)	25 gal.	
Steering Gear Type	Integral Power	
Transmission	5-Speed Manual (w/Overdrive)	
Shift Location	Floor	
Transfer Case	New Process 241 2-Speed	
Shift Lever	Single Lever	
Tires	(5) LT225/75R16C (6PR)	(5) LT245/75R16C (6PR)
Wheels	(5) Disc	
Size	16" x 6.5"	

♦CCA-Cold Cranking Amps

C/K PICKUP—4-Wheel Drive

DIESEL

**K1500 REGULAR CABS
K1500 EXTENDED CABS**

STANDARD SPECIFICATIONS

(See Gray Tab Section for Specification Details)

Series	▲K1500 Regular Cab	K1500 Extended Cab
Engine	6.2 Liter, 379 Cu. In. V8 Diesel	
Base Equip.	12"; 150 sq. in.	
Clutch	Poly-wrapped Oiled-paper Element	
Air Filter	Throwaway Type	
Oil Filter	Dual; Aluminized	
Exhaust System	See Engine & Cooling Section for specific model applications	
Emission Control Systems		
Suspension, Front	Independent; Torsion Bars	
Capacity — 131.5" WB	3450 lb.	—
— 155.5" WB	—	3925 lb.
Axle Ratio	3.42	
Springs @ Ground	1930 lb. ea.	
Shock Absorbers	25mm dia.	
Suspension, Rear	Salisbury Axle; Hypoid Drive; Two-stage Multi-leaf Springs	
Axle Capacity	3750 lb.	
Axle Ratio	3.42	
Springs @ Ground	1875 lb. ea.	
Shock Absorbers	25mm dia.	
Brakes	Hydraulic, Self-adjusting	
Front	Disc; 11.86" Rotor	
Rear	Drum; 11" x 2"	
Booster	Dual Diaphragm	
Parking	Cable to Rear Wheels	
Electrical	12 Volt; Negative Ground	
Battery — Freedom Type	Two 550 CCA♦ ea. @ 0°F.	
— Reserve Capacity	115 min. ea. @ 80°F.	
Delcotron Generator	66 amp.	
Engine Block Heater	600 watts, 120 volts	
Frame	Carbon Steel; 36,-39,000 psi	
Section Modulus	3.46	4.30
Fuel Tank (nominal capacity) ..	25 gal.	
Steering Gear Type	Integral Power	
Transmission	4-Speed Manual (SM 465)	
Shift Location	Floor	
Transfer Case	New Process 241 2-Speed	
Shift Lever	Single Lever	
Tires	(5) LT225/75R16C (6PR)	(5) LT245/75R16C (6PR)
Wheels	(5) Disc	
Size	16" x 6"	

▲Available on K10903 model only.

♦CCA-Cold Cranking Amps

GASOLINE**C/K PICKUP—4-Wheel Drive****K2500 REGULAR CABS
K2500 EXTENDED CABS****STANDARD SPECIFICATIONS**

(See Gray Tab Section for Specification Details)

Series	K2500 Regular Cab	K2500 Extended Cab
Engine		
Base Equip.	4.3 Liter, 262 EFI V6	
Clutch	11"; 124 sq. in.	
Air Filter	Oiled-paper Element	
Oil Filter	Throwaway Type	
Exhaust System	Single; Aluminized	
Emission Control Systems	See Engine & Cooling Section for specific model applications	
Suspension, Front	Independent; Torsion Bars	
Capacity	3925 lb.	
Axle Ratio	3.42	
Springs @ Ground	1875-1963 lb. ea.	
Shock Absorbers	32mm dia.	
Suspension, Rear	Salisbury Axle; Hypoid Drive; Two-stage Multi-leaf Springs	
Axle Capacity	4800 lb.	
Axle Ratio	3.42	
Springs @ Ground	2400 lb. ea.	
Shock Absorbers	32mm dia.	
Brakes	Hydraulic, Self-adjusting	
Front	Disc; 11.57" Rotor	
Rear	Drum; 11.15" x 2.75"	
Booster	Dual Diaphragm	
Parking	Cable to Rear Wheels	
Electrical	12 Volt; Negative Ground	
Battery—Freedom Type	525 CCA♦ @ 0°F.	
— Reserve Capacity	90 min. @ 80°F.	
Delcotron Generator	85 amp.	
Frame	Carbon Steel; 36,-39,000 psi	
Section Modulus	3.46	4.30
Fuel Tank (nominal capacity)	25 gal.	
Steering Gear Type	Integral Power	
Transmission	5-Speed Manual (w/Overdrive)	
Shift Location	Floor	
Transfer Case	New Process 241 2-Speed	
Shift Lever	Single Lever	
Tires	(4) LT225/75R16D (8PR)	(4) LT 245/75R16C (6PR)
Wheels	(4) Disc	
Size	16" x 6.5"	

♦CCA-Cold Cranking Amps

C/K PICKUP—4-Wheel Drive

DIESEL

**K2500 REGULAR CABS
K2500 EXTENDED CABS**

STANDARD SPECIFICATIONS

(See Gray Tab Section for Specification Details)

Series	K2500 Regular Cab	K2500 Extended Cab
Engine Base Equip.	6.2 Liter, 379 Cu. In. V8 Diesel	
Clutch	12"; 150 sq. in.	
Air Filter	Poly-wrapped, Oiled-paper Element	
Oil Filter	Throwaway Type	
Oil Cooler	Standard	
Exhaust System	Single; Aluminized	
Emission Control Systems	See Engine & Cooling Section for specific model applications	
Suspension, Front	Independent; Torsion Bars	
Capacity	3925 lb.	
Axle Ratio	3.42	
Springs @ Ground	1875-1963 lb. ea.	
Shock Absorbers	32mm dia.	
Suspension, Rear	Salisbury Axle; Hypoid Drive; Two-stage Multi-leaf Springs	
Axle Capacity	4800 lb.	
Axle Ratio	3.42	
Springs, Main @ Ground	2400 lb. ea.	
Shock Absorbers	32mm dia.	
Brakes	Hydraulic, Self-adjusting	
Front	Disc; 11.57" Rotor	
Rear	Drum; 11.15" x 2.75"	
Booster	Hydraulic Power	
Parking	Cable to Rear Wheels	
Electrical	12 Volt; Negative Ground	
Battery—Freedom Type	Two: 570 CCA♦ ea. @ 0°F.	
—Reserve Capacity	90 min. ea. @ 80°F.	
Delcotron Generator	85 amp.	
Engine Block Heater	600 watts, 120 volts	
Frame	Carbon Steel; 36,-39,000 psi	
Section Modulus	3.46	4.30
Fuel Tank (nominal capacity) ..	25 gal.	
Steering Gear Type	Integral Power	
Transmission	4-Speed Manual (SM 465)	
Shift Location	Floor	
Transfer Case	New Process 241 2-Speed	
Shift Lever	Single Lever	
Tires	(4) LT 225/75R16D (8PR)	(4) LT245/75R16C (6PR)
Wheels	(4) Disc	
Size	16" x 6.5"	

♦CCA-Cold Cranking Amps

GASOLINE

C/K PICKUP—4-Wheel Drive

**K3500 REGULAR CABS
K3500 EXTENDED CABS**

STANDARD SPECIFICATIONS

(See Gray Tab Section for Specification Details)

Series	K3500 Regular Cab	K3500 Extended Cab
Engine	5.7 Liter, 350 EFI V8	
Base Equip.	12"; 150 sq. in.	
Clutch	Oiled-paper Element	
Air Filter	Throwaway Type	
Oil Filter	Single; Stainless Steel	
Exhaust System	See Engine & Cooling Section for specific model applications	
Emission Control Systems		
Suspension, Front	Independent; Torsion Bars	
Capacity	4250 lb.	
Axle Ratio	3.42	
Springs @ Ground	1875-2125 lb. ea.	
Shock Absorbers	32mm	
Suspension, Rear	Salisbury Axle; Hypoid Drive; Two-stage Multi-leaf Springs	
Axle Capacity	6000 lb.	
Axle Ratio	3.42	
Springs @ Ground	3000 lb. ea.	
Shock Absorbers	32mm dia.	
Brakes	Hydraulic, Self-adjusting	
Front	Disc; 12.5" rotor	
Rear	Drum; 13" x 2.5"	
Booster	Dual Diaphragm	
Parking	Cable to Rear Wheels	
Electrical	12 Volt; Negative Ground	
Battery—Freedom Type	525 CCA♦ ea. @ 0°F.	
—Reserve Capacity	90 min. @ 80°F.	
Delcotron Generator	85 amp.	
Frame	Carbon Steel; 36,-39,000 psi	
Section Modulus	5.61	6.48
Fuel Tank (Nominal Capacity)	25 gal.	
Steering Gear Type	Integral Power	
Transmission	4-Speed Manual (SM 465)	
Shift Location	Floor	
Transfer Case	New Process 241 2-Speed	
Shift Lever	Single Lever	
Tires	(4) LT 245/75R16E (10PR)	
Wheels	(4) Disc	
Size	16" x 6.5"	

♦CCA-Cold Cranking Amps

C/K PICKUP—4-Wheel Drive

DIESEL

**K3500 REGULAR CABS
K3500 EXTENDED CABS**

STANDARD SPECIFICATIONS

(See Gray Tab Section for Specification Details)

Series	K3500 Regular Cab	K3500 Extended Cab
Engine	6.2 Liter, 379 Cu. In. V8 Diesel	
Base Equip.	12"; 150 sq. in.	
Clutch	Poly-wrapped, Oiled-paper Element	
Air Filter	Throwaway type	
Oil Filter	Standard	
Oil Cooler	Single; Aluminized	
Exhaust System	See Engine & Cooling Section for specific model applications	
Emission Control Systems		
Suspension, Front	Independent; Torsion Bars	
Capacity	4250 lb.	
Axle Ratio	3.73	
Springs @ Ground	1875-2125 lb. ea.	
Shock Absorbers	32mm	
Suspension, Rear	Salisbury Axle; Hypoid Drive; Two-stage Multi-leaf Springs	
Axle Capacity	6000 lb.	
Axle Ratio	3.73	
Springs @ Ground	3000 lb. ea.	
Shock Absorbers	32mm dia.	
Brakes	Hydraulic, Self-adjusting	
Front	Disc; 12.5" rotor	
Rear	Drum; 13" x 2.5"	
Booster	Hydraulic Power	
Parking	Cable to Rear Wheels	
Electrical	12 Volt; Negative Ground	
Battery—Freedom Type	Two; 570 CCA♦ ea. @ 0°F.	
—Reserve Capacity	90 min. @ 80°F.	
Delcotron Generator	85 amp.	
Engine Block Heater	600 watts, 120 volts	
Frame	Carbon Steel; 36,-39,000 psi	
Section Modulus	5.61	6.48
Fuel Tank (Nominal Capacity)	25 gal.	
Steering Gear Type	Integral Power	
Transmission	4-Speed Manual (SM 465)	
Shift Location	Floor	
Transfer Case	New Process 241 2-Speed	
Shift Lever	Single Lever	
Tires	(4) LT245/75R16E (10PR)	
Wheels	(4) Disc	
Size	16" x 6.5"	

♦CCA-Cold Cranking Amps

GASOLINE

C/K PICKUP

C1500-3500 SERIES FLEETSIDE/WIDESIDE PICKUP

Body Ordering Codes:

Regular Cab—E63

Extended Cab—E63

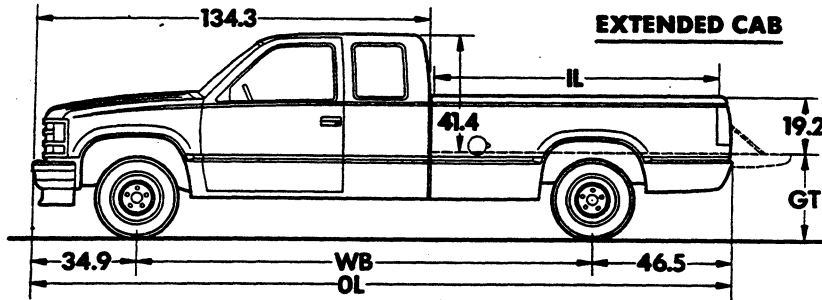

Sign Panel Area (side)
 Regular Cab—17" x 48½"
 Extended Cab—17" x 77½"

REGULAR CAB

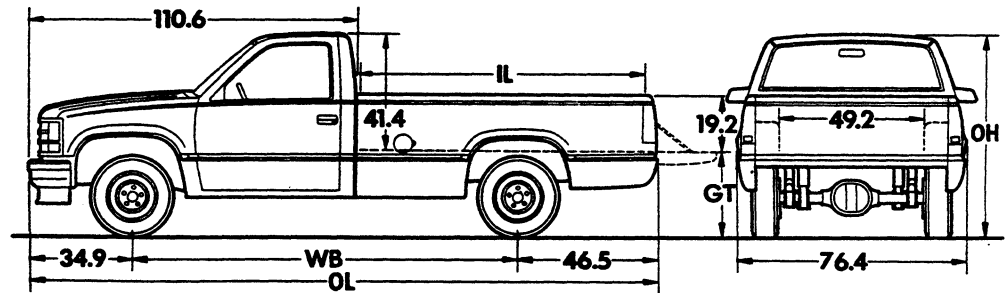

Model	Wheelbase (in)	Body-Payload Weight Distribution*	
		% Front	% Rear
C1	117.5	1	99
C1-3	131.5	4	96
C1-3	155.5	3	97

*Estimate based on water-level loading.

Series	Ground Clearance (in)*	
	Front	Rear
C1 (03)	6.1	7.5
C1 (53)	7.2	7.1
C2 (03)	7.8	7.8
C2 (53)	7.9	7.7
C3 (03)	8.4	8.1
C3 (53)	8.4	8.0

Model	Engine No. Cyl.	Dimensions (in)*					Curb Weight (lb)			Model Weight (lb)*			Payload (lb)▲
		WB	IL	OL	OH	GT	Front	Rear	Total	Front	Rear	Total	

C1500 SERIES

C10703	6	117.5	78.7	194.1	70.4	29.0	2131	1524	3655	2351	1754	4105	1541
C10903	6	131.5	97.6	212.9	70.4	29.0	2170	1559	3729	2416	1763	4179	1465
C10953	6	155.5	97.6	236.9	70.5	29.0	2369	1705	4074	2644	1880	4524	1896

C2500 SERIES

C20903	6	131.5	97.6	212.9	73.0	31.6	2245	1688	3933	2491	1892	4383	3276
C20953	6	155.5	97.6	236.9	73.0	31.6	2415	1809	4224	2690	1984	4674	2964

C3500 SERIES

C30903	8	131.5	97.6	212.9	75.5	34.0	2425	1868	4293	2671	2072	4743	4169
C30953	8	155.5	97.6	236.9	75.5	34.0	2603	1959	4562	2878	2134	5012	3879

*Dimensions with standard equipment, unloaded. *Model Weight includes Curb Weight plus occupants (standard seating capacity x 150 lb.).

▲Total Model Weight may vary as much as ±50 lbs. to allow for production build variation.

▲With standard equipment.

C/K PICKUP

C2500-3500 SERIES FLEETSIDE/WIDESIDE PICKUP

DIESEL

Body Ordering Codes:

Regular Cab—E63

Extended Cab—E63

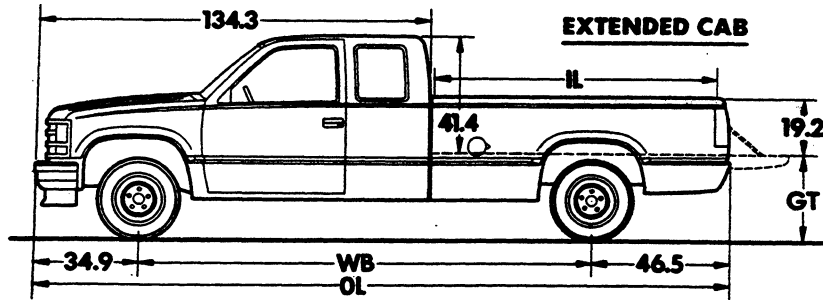

Sign Panel Area (side)
 Regular Cab—17" x 48½"
 Extended Cab—17" x 77½"

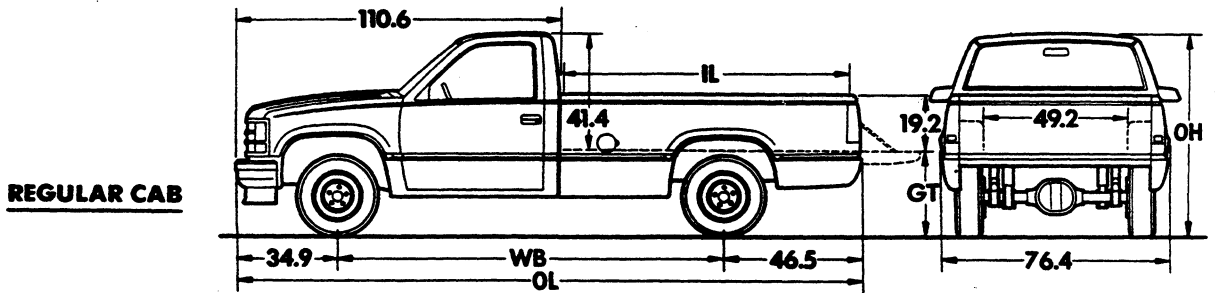

EXTENDED CAB
REGULAR CAB

Sign Panel Area (side)
 Regular Cab—17" x 48½"
 Extended Cab—17" x 77½"

Model	Wheelbase (in)	Body—Payload Weight Distribution*	
		% Front	% Rear
C1	131.5	4	96
C2-3	131.5	4	96
C2-3	155.5	3	97

*Estimate based on water-level loading.

Series	Ground Clearance (in)*	
	Front	Rear
C1 (03)	6.1	7.5
C1 (53)	7.2	7.1
C2 (03)	7.8	7.8
C2 (53)	7.9	7.7
C3 (03)	8.4	8.1
C3 (53)	8.4	8.0

Model	Engine No. Cyl.	Dimensions (in)*					Curb Weight (lb)			Model Weight (lb)*			Payload (lb)▲
		WB	IL	OL	OH	GT	Front	Rear	Total	Front	Rear	Total	

C1500 SERIES

C10903	8	131.5	97.6	212.9	70.4	29.0							
C10953	8	131.5	97.6	236.9	70.5	29.0							

C2500 SERIES

C20903	8	131.5	97.6	212.9	73.0	31.6	2637	1703	4340	2883	1907	4790	2403
C20953	8	155.5	97.6	236.9	73.0	31.6	2807	1825	4632	3082	2000	5082	2088

C3500 SERIES

C30903	8	131.5	97.6	212.9	75.5	34.0	2820	1883	4703	3066	2087	5153	3513
C30953	8	155.5	97.6	236.9	75.5	34.0	2999	1974	4973	3274	2149	5423	3214

★Dimensions with standard equipment, unloaded. *Model Weight includes Curb Weight plus occupants (standard seating capacity x 150 lb.). Total Model Weight may vary as much as ±50 lbs. to allow for production build variation.

▲With standard equipment.

C/K PICKUP

GASOLINE

K1500-3500 SERIES FLEETSIDE/WIDESIDE PICKUP

Body Ordering Codes:

Regular Cab—E63

Extended Cab—E63

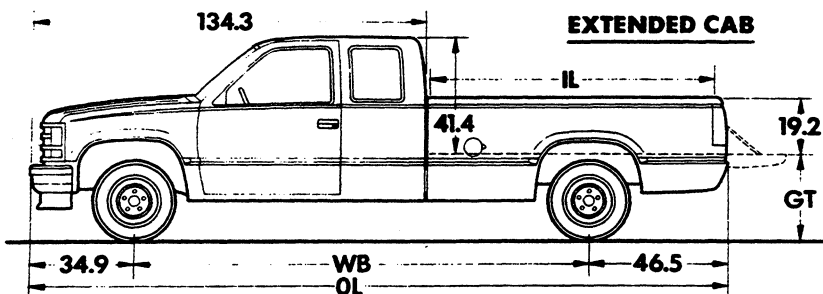

Sign Panel Area (side)
 Regular Cab—17" x 48½"
 Extended Cab—17" x 77½"

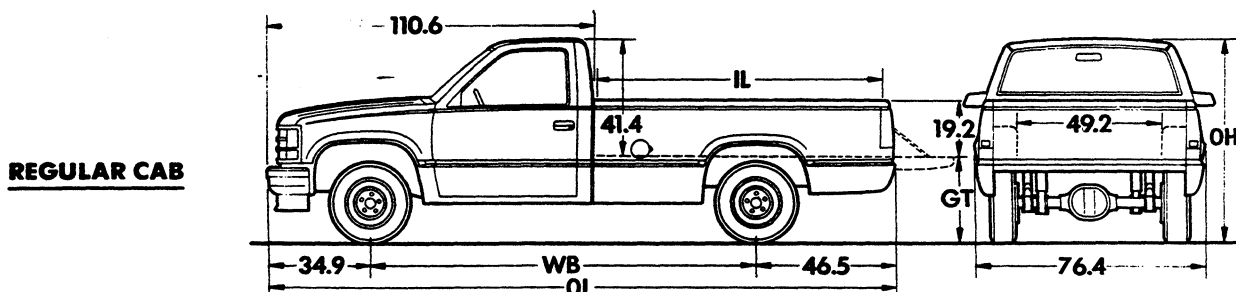

Model	Wheelbase (in)	Body-Payload Weight Distribution*	
		% Front	% Rear
K1	117.5	1	99
K1-3	131.5	4	96
K1-3	155.5	3	97

*Estimate based on water-level loading.

Series	Ground Clearance (in)*	
	Front	Rear
K1 (03)	8.6	9.0
K1 (53)	9.2	9.6
K2 (03)	8.7	7.7
K2 (53)	9.2	8.2
K3 (03)	7.8	8.1
K3 (53)	7.7	8.1

Model	Engine No. Cyl.	Dimensions (in)*					Curb Weight (lb)			Model Weight (lb)*			Payload (lb)▲
		WB	IL	OL	OH	GT	Front	Rear	Total	Front	Rear	Total	

K1500 SERIES

K10703	6	117.5	78.4	194.1	73.8	32.3	2431	1666	4097	2651	1896	4547	1506
K10903	6	131.5	97.6	212.9	73.8	32.3	2486	1692	4178	2732	1896	4628	1425
K10953	6	155.5	97.6	236.9	73.9	32.3	2695	1826	4521	2970	2001	4971	1648

K2500 SERIES

K20903	6	131.5	97.6	212.9	74.3	32.9	2524	1761	4285	2770	1965	4735	2913
K20953	6	155.5	97.6	236.9	74.5	32.9	2708	1872	4580	2983	2047	5030	2597

K3500 SERIES

K30903	8	131.5	97.6	212.9	75.8	34.4	2755	1928	4683	3001	2132	5133	3790
K30953	8	155.5	97.6	236.9	76.0	34.4	2934	2026	4960	3209	2201	5410	3493

★Dimensions with standard equipment, unloaded. *Model Weight includes Curb Weight plus occupants (standard seating capacity x 150 lb). Total Model Weight may vary as much as ±50 lbs. to allow for production build variation.

▲With standard equipment.

C/K PICKUP

K2500-3500 SERIES FLEETSIDE/WIDESIDE PICKUP

DIESEL

Body Ordering Codes:

Regular Cab—E63

Extended Cab—E63

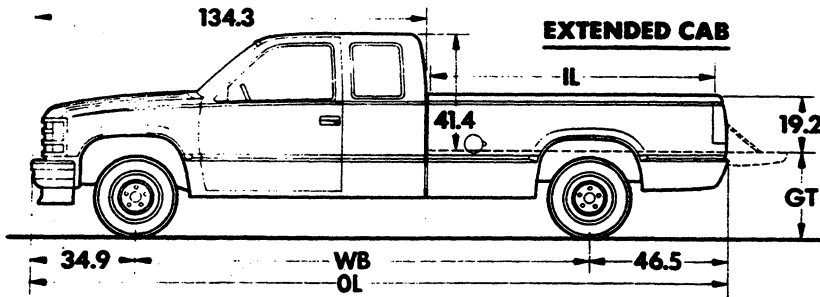

Sign Panel Area (side)
 Regular Cab—17" x 48½"
 Extended Cab—17" x 77½"

REGULAR CAB

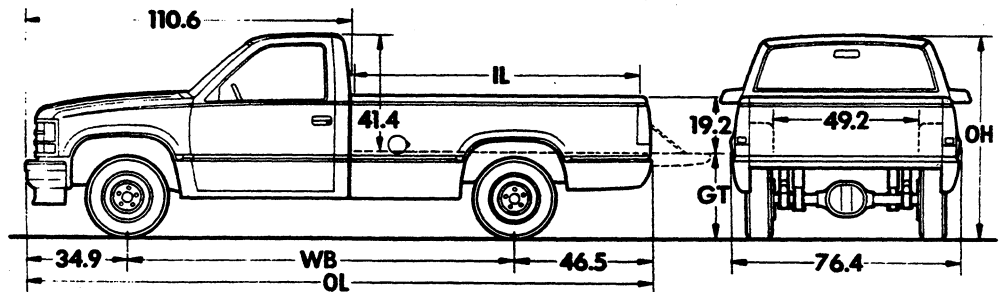

Sign Panel Area (side)
 Regular Cab—17" x 48½"
 Extended Cab—17" x 77½"

Model	Wheelbase (in)	Body—Payload Weight Distribution*	
		% Front	% Rear
K1	131.5	4	96
K2-3	131.5	4	96
K2-3	155.5	3	97

*Estimate based on water-level loading.

Series	Ground Clearance (in)*	
	Front	Rear
K1 (03)	8.6	9.0
K1 (53)	9.2	9.6
K2 (03)	8.7	7.7
K2 (53)	9.2	8.2
K3 (03)	7.8	8.1
K3 (53)	7.7	8.1

Model	Engine No. Cyl.	Dimensions (in)*					Curb Weight (lb)			Model Weight (lb)*			Payload (lb)▲	
		WB	IL	OL	OH	GT	Front	Rear	Total	Front	Rear	Total		
K1500 SERIES														
K10903	8	131.5	97.6	212.9	73.8	32.3								
K10953	8	155.5	97.6	236.9	73.9	32.3								
K2500 SERIES														
K20903	8	131.5	97.6	212.9	74.3	32.9	2916	1776	4692	3162	1980	5142	2403	
K20953	8	155.5	97.6	236.9	74.5	32.9	3100	1888	4988	3375	2063	5438	2088	
K3500 SERIES														
K30903	8	131.5	97.6	212.9	75.8	34.4	3150	1943	5093	3396	2147	5543	3513	
K30953	8	155.5	97.6	236.9	76.0	34.4	3330	2041	5371	3605	2216	5821	3214	

*Dimensions with standard equipment, unloaded. *Model Weight includes Curb Weight plus occupants (standard seating capacity x 150 lb). Total Model Weight may vary as much as ±50 lbs. to allow for production build variation.

▲With standard equipment.

GASOLINE

C/K PICKUP
C1500-K1500 SPORTSIDE PICKUP

Body Ordering Code—E62

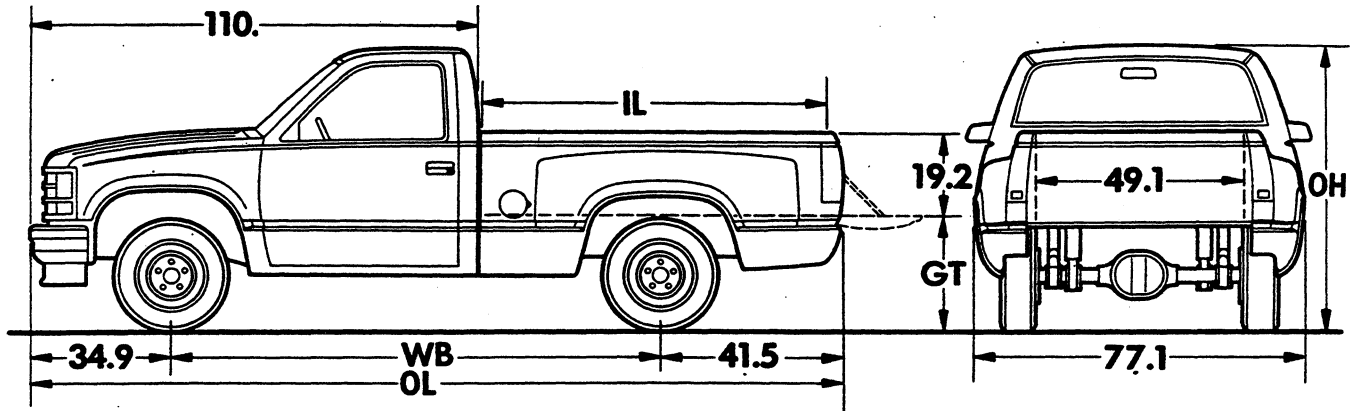

Sign Panel Area (side)

17" x 48 3/4"

Model	Wheelbase (in.)	Body—Payload Weight Distribution*	
		% Front	% Rear
C-K1	117.5	1	99

*Estimate based on water-level loading.

Series	Ground Clearance (in.)*	
	Front	Rear
C1	7.5	7.2
K1	7.2	7.1

Model	Engine No. Cyl.	Dimensions (in)*					Curb Weight (lb)			Model Weight (lb)*			Payload (lb)▲
		WB	IL	OL	OH	GT	Front	Rear	Total	Front	Rear	Total	

C1500 SERIES

C10703	6	117.5	78.4	194.0	70.4	29.0	2134	1568	3702	2354	1798	4152	1494
---------------	---	-------	------	-------	------	------	------	------	------	------	------	------	------

K1500 SERIES

K10703	6	117.5	78.4	194.0	73.8	32.4	2434	1710	4144	2654	1940	4594	1459
---------------	---	-------	------	-------	------	------	------	------	------	------	------	------	------

★ Dimensions with standard equipment, unloaded. *Model Weight includes Curb Weight plus occupants (standard seating capacity x 150 lb.). Total Model Weight may vary as much as ± 50 lbs. to allow for production build variation.
 ▲ With standard equipment.

NOTES

C/K PICKUP
POWER TEAMS
ALL STATES EXCEPT CALIFORNIA
C/K1500 SERIES

✓ POWER TEAMS (MUST ORDER ENGINE, TRANSMISSION AND REAR AXLE)
 (Consult GVWR Selector and Tire Chart to insure tire capacity and availability)

ENGINE	TRANSMISSION			AXLES				GVWR	
	4-SP	5-SP	AUTO	2.73	3.08	3.42	3.73		
W/NA5 STANDARD EMISSION EQUIPMENT									
-C10703-C10903									
LB4 V6 4.3 Liter (262 Cu In)-EFI	#MM4	MM5	MX1		GQ1	GU4	GU6	—	52/5600
			MX0		—	GQ1	GU6	—	52/5600
L03 V8 5.0 Liter (305 Cu In)-EFI		MM5			—	GQ1	GU6	—	52/5600
			MX1/O		GQ1	GU4	GU6	—	52/5600
L05 V8 5.7 Liter (350 Cu In)-EFI	#MM4	MM5			—	GQ1	GU6	—	52/5600
			MX0		GQ1	GU4	GU6	@GT4	52/5600
-C10953									
LB4 V6 4.3 Liter (262 Cu In)-EFI	MM4	MM5	MX1		GQ1	GU4	GU6	—	6000
			MX0		—	GQ1	GU6	—	6000
L03 V8 5.0 Liter (305 Cu In)-EFI		MM5	MX1/O		GQ1	GU4	GU6	—	6000
					—	GQ1	GU6	—	6000
L05 V8 5.7 Liter (350 Cu In)-EFI	MM4	MM5	MX0		GQ1	GU4	GU6	@GT4	6000
					—	GQ1	GU6	—	6000
-K10703-K10903									
LB4 V6 4.3 Liter (262 Cu In)-EFI	MM4	MM5	MX1/O		—	—	*GQ1	%GT4	5600
					—	—	*GQ1	GT4	5600
L03 V8 5.0 Liter (305 Cu In)-EFI		MM5	MX1/O		—	—	*GQ1	GT4	5600
L05 V8 5.7 Liter (350 Cu In)-EFI	MM4	MM5	MX0		—	—	GQ1	%GT4	5600
-K10953									
LB4 V6 4.3 Liter (262 Cu In)-EFI	MM4	MM5	MX1/O		—	—	GQ1	%GT4	6200
					—	—	GQ1	GT4	6200
L03 V8 5.0 Liter (305 Cu In)-EFI		MM5	MX1/O		—	—	GQ1	GT4	6200
L05 V8 5.7 Liter (350 Cu In)-EFI	MM4	MM5	MX0		—	—	GQ1	%GT4	6200
W/NA6 HIGH ALTITUDE EMISSION EQUIPMENT									
-C10703-C10903									
LB4 V6 4.3 Liter (262 Cu In)-EFI	#MM4	MM5	MX1		—	GQ1	GU6	—	52/5600
			MX0		—	—	GQ1	@GT4	52/5600
L03 V8 5.0 Liter (305 Cu In)-EFI		MM5	MX1/O		—	GQ1	GU6	—	52/5600
					—	GQ1	GU6	—	52/5600
L05 V8 5.7 Liter (350 Cu In)-EFI	#MM4	MM5			—	GQ1	GU6	—	52/5600
			MX0		GQ1	GU4	GU6	@GT4	52/5600
-C10953									
LB4 V6 4.3 Liter (262 Cu In)-EFI	MM4				—	—	GQ1	—	6000
			MX0		—	—	GQ1	@GT4	6000
			MX1		—	GQ1	GU6	—	6000
L03 V8 5.0 Liter (305 Cu In)-EFI		MM5	MX1/O		—	GQ1	GU6	—	6000
L05 V8 5.7 Liter (350 Cu In)-EFI	MM4	MM5			—	GQ1	GU6	—	6000
			MX0		GQ1	GU4	GU6	@GT4	6000

*N/A LT 265/75R16C Tires
 #N/A C10703 Model
 @Reqs KC4 Eng Oil Cooler and V02 H.D. Cooling
 %Reqs KC4 Eng Oil Cooler; w/MX1 or MX0 Also Reqs V02 H.D. Cooling

C/K PICKUP
POWER TEAMS
ALL STATES EXCEPT CALIFORNIA
C/K1500 SERIES

POWER TEAMS (MUST ORDER ENGINE, TRANSMISSION AND REAR AXLE)
 (Consult GVWR Selector and Tire Chart to insure tire capacity and availability)

ENGINE	TRANSMISSION				AXLES					GVWR
	4-SP	5-SP	AUTO		2.73	3.08	3.42	3.73	4.10	
W/NA6 HIGH ALTITUDE EMISSION EQUIPMENT										
-K10703-K10903										
LB4 V6 4.3 Liter (262 Cu In)-EFI	MM4	MM5	MX1/0		—	—	*GQ1	%GT4	—	5600
L03 V8 5.0 Liter (305 Cu In)-EFI		MM5	MX1/0		—	—	*GQ1	GT4	—	5600
L05 V8 5.7 Liter (350 Cu In)-EFI	MM4	MM5	MX0		—	—	GQ1	%GT4	—	5600
-K10953										
LB4 V6 4.3 Liter (262 Cu In)-EFI	MM4	MM5	MX1/0		—	—	GQ1	%GT4	—	6200
L03 V8 5.0 Liter (305 Cu In)-EFI		MM5			—	—	GQ1	GT4	—	6200
			MX1/0		—	—	GQ1	GT4	GT5	6200
L05 V8 5.7 Liter (350 Cu In)-EFI	MM4	MM5			—	—	GQ1	%GT4	—	6200
			MX0		—	—	GQ1	@GT4	@GT5	6200

CALIFORNIA ONLY
C/K1500 SERIES

ENGINE	TRANSMISSION				AXLES					GVWR
	4-SP	5-SP	AUTO		2.73	3.08	3.42	3.73	4.10	
W/YF5 CALIFORNIA EMISSION REQUIREMENTS										
-C10703-C10903										
LB4 V6 4.3 Liter (262 Cu In)-EFI	#MM4	MM5	MX0		—	GQ1	GU6	—	—	52/5600
L03 V8 5.0 Liter (305 Cu In)-EFI			MX0		GQ1	GU4	GU6	—	—	52/5600
L05 V8 5.7 Liter (350 Cu In)-EFI			MX0		GQ1	GU4	GU6	@GT4	—	52/5600
-C10953										
LB4 4.3 Liter (262 Cu In)-EFI	MM4	MM5	MX0		—	GQ1	GU6	—	—	6000
L03 V8 5.0 Liter (305 Cu In)-EFI			MX0		GQ1	GU4	GU6	—	—	6000
L05 V8 5.7 Liter (350 Cu In)-EFI			MX0		GQ1	GU4	GU6	@GT4	—	6000
-K10703-K10903										
LB4 V6 4.3 Liter (262 Cu In)-EFI	MM4	MM5	MX0		—	—	*GQ1	%GT4	—	5600
L03 V8 5.0 Liter (305 Cu In)-EFI			MX0		—	—	*GQ1	GT4	—	5600
L05 V8 5.7 Liter (350 Cu In)-EFI			MX0		—	—	GQ1	@GT4	—	5600
-K10953										
LB4 V6 4.3 Liter (262 Cu In)-EFI	MM4	MM5	MX0		—	—	GQ1	%GT4	—	6200
L03 V8 5.0 Liter (305 Cu In)-EFI			MX0		—	—	GQ1	GT4	—	6200
L05 V8 5.7 Liter (350 Cu In)-EFI			MX0		—	—	GQ1	@GT4	—	6200

%Reqs KC4 Eng Oil Cooler; w/MX1 or MX0 Also
 Reqs V02 H.D. Cooling
 #N/A C10703
 *N/A LT265/75R16C Tires
 @Req KC4 Eng Oil Cooler and V02 H.D. Cooling

**C/K PICKUP
POWER TEAMS
ALL STATES EXCEPT CALIFORNIA
C/K2500 SERIES**

POWER TEAMS (MUST ORDER ENGINE, TRANSMISSION AND REAR AXLE)
(Consult GVWR Selector and Tire Chart to insure tire capacity and availability)

ENGINE	TRANSMISSION				AXLES			GVWR
	4-SP	5-SP	AUTO		3.42	3.73	4.10	
W/NA5 STANDARD EMISSION EQUIPMENT								
-C20903-C20953								
LB4 V6 4.3 Liter (262 Cu In)-EFI	MM4	MM5	MX1		GQ1	%GT4	—	7200
			MX0		GQ1	@GT4	@GT5	7200
L03 V8 5.0 Liter (305 Cu In)-EFI		MM5			GQ1	GT4	—	7200
			MX1/0		GQ1	GT4	GT5	7200
L05 V8 5.7 Liter (350 Cu In)-EFI	MM4	MM5			GQ1	GT4	—	7200
			MX0		GQ1	@GT4	@GT5	7200
LH6 Diesel 6.2 Liter V8 (379 Cu In) (Reqs B3J)	MM4		MX0		GQ1	GT4	—	7200
-K20903-K20953								
LB4 V6 4.3 Liter (262 Cu In)-EFI	MM4	MM5	MX1		GQ1	%GT4	—	7200
			MX0		GQ1	@GT4	@GT5	7200
L03 V8 5.0 Liter (305 Cu In)-EFI		MM5			GQ1	GT4	—	7200
			MX1/0		GQ1	GT4	GT5	7200
L05 V8 5.7 Liter (350 Cu In)-EFI	MM4	MM5			GQ1	GT4	—	7200
			MX0		GQ1	@GT4	@GT5	7200
LH6 Diesel 6.2 Liter V8 (379 Cu In) (Reqs B3J)	MM4		MX0		GQ1	GT4	GT5	7200
					GQ1	GT4	—	7200
W/NA6 HIGH ALTITUDE EMISSION EQUIPMENT								
-C20903-C20953								
LB4 V6 4.3 Liter (262 Cu In)-EFI	MM4	MM5	MX1		—	%GQ1	—	7200
			MX0		—	@GQ1	@GT5	7200
L03 V8 5.0 Liter (305 Cu In)-EFI		MM5			GQ1	GT4	GT5	7200
			MX1/0		GQ1	GT4	—	7200
L05 V8 5.7 Liter (350 Cu In)-EFI	MM4	MM5			GQ1	GT4	—	7200
			MX0		GQ1	@GT4	@GT5	7200
LH6 Diesel 6.2 Liter V8 (379 Cu In) (Reqs B3J)	MM4				—	GQ1	GT5	7200
			MX0		GQ1	GT4	—	7200
-K20903-K20953								
LB4 V6 4.3 Liter (262 Cu In)-EFI	MM4	MM5	MX1		GQ1	%GT4	—	7200
			MX0		—	@GQ1	@GT5	7200
L03 V8 5.0 Liter (305 Cu In)-EFI		MM5			GQ1	GT4	—	7200
			MX1/0		GQ1	GT4	GT5	7200
L05 V8 5.7 Liter (350 Cu In)-EFI	MM4	MM5			GQ1	GT4	—	7200
			MX0		GQ1	@GT4	@GT5	7200
LH6 Diesel 6.2 Liter V8 (379 Cu In) (Reqs B3J)	MM4				GQ1	GT4	—	7200
			MX0		GQ1	GT4	GT5	7200

**CALIFORNIA ONLY
C/K2500 SERIES**

ENGINE	TRANSMISSION				AXLES			GVWR
	4-SP	5-SP	AUTO		3.42	3.73	4.10	
W/YF5 CALIFORNIA EMISSION REQUIREMENTS								
-C20903-C20953-K20903-K20953								
LB4 V6 4.3 Liter (262 Cu In)-EFI	MM4	MM5			GQ1	%GT4	—	7200
			MX0		GQ1	@GT4	@GT5	7200
L03 V8 5.0 Liter (305 Cu In)-EFI			MX0		GQ1	GT4	GT5	7200
			MX0		GQ1	@GT4	@GT5	7200

%Reqs KC4 Eng Oil Cooler; w/MX1 or MX0 Also Req V02 H.D. Cooling
@Reqs KC4 Eng Oil Cooler and V02 H.D. Cooling

**C/K PICKUP
POWER TEAMS
ALL STATES
C/K3500 SERIES**

POWER TEAMS (MUST ORDER ENGINE, TRANSMISSION AND REAR AXLE)
(Consult GVWR Selector and Tire Chart to insure tire capacity and availability)

ENGINE	TRANSMISSION		AXLES				GVWR
	4-SP	AUTO	3.42	3.73	4.10	4.56	
W/NA5 STANDARD, NA6 HIGH ALTITUDE OR YF5 CALIFORNIA EMISSIONS							
-C30903-C30953							
L05 V8 5.7 Liter (350 Cu In)-EFI	MM4		GQ1	§GT4	§GT5	—	8600
		MX1	—	*GQ1	*GT5	*HC4	8600
#L19 V8 7.4 Liter (454 Cu In)-EFI	MM4	%MX1	—	—	§GQ1	§§HC4	#10000
		MX1	GQ1	GT4	@GT5	—	#8600
LL4 Diesel 6.2 Liter V8 (379 Cu In)(Reqs B3J)	MM4	%MX1	—	GQ1	§GT5	§§HC4	#10000
		MX1	—	GQ1	GT5	—	8600
MM4	MX1		—	—	GQ1	HC4	8600
		%MX1	—	—	GQ1	HC4	#10000
-K30903-K30953							
L05 V8 5.7 Liter (350 Cu In)-EFI	MM4		GQ1	§GT4	§GT5	—	8600
		MX1	—	*GQ1	*GT5	*HC4	8600
#L19 V8 7.4 Liter (454 Cu In)-EFI	MM4	MX1	GQ1	GT4	@GT5	—	8600
		%MX1	—	GQ1	GT5	—	8600
LL4 Diesel 6.2 Liter V8 (379 Cu In)(Reqs B3J)	MM4		—	GQ1	GT5	—	8600
		MX1	—	GQ1	GT5	HC4	8600

§Reqs KC4 Eng Oil Cooler
%Reqs V02 H.D. Cooling
#N/A G80 Locking Differential
*Reqs KC4 Eng Oil Cooler and V02 H.D. Cooling
@Reqs KC4 Eng Oil Cooler; w/MX1 Also Reqs V02 H.D. Cooling
§§Reqs KC4 Eng Oil Cooler; w/MX1 Also Reqs 7.50-16/D Tires

**ENGINE RATINGS
ALL STATES**

SAE Net Ratings	▲4.3 Liter 262 EFI V8	▲5.0 Liter 305 EFI V8
Net Horsepower	160 @ 4000 rpm	175 @ 4000 rpm
Net Torque, lb-ft	235 @ 2400 rpm	270 @ 2400 rpm

SAE Net Ratings	▲5.7 Liter 350 EFI V8	■5.7 liter 350 EFI V8	■7.4 Liter 454 EFI V8
Net Horsepower	210 @ 4000 rpm	185 @ 4000 rpm	230 @ 3600 rpm
Net Torque, lb-ft	300 @ 2800 rpm	295 @ 2400 rpm	385 @ 1600 rpm

SAE Net Ratings	▲6.2 Liter 379 V8 Diesel	■6.2 Liter 379 V8 Diesel
Net Horsepower	†126 @ 3600 rpm	143 @ 3600 rpm
Net Torque, lb-ft	†240 @ 2000 rpm	257 @ 2000 rpm

▲For models with a GVWR up to 8500 lbs.
■For models with a GVWR from 8501 lbs. to 10,000 lbs.
† When Automatic Transmission is ordered, ratings are:
Net Horsepower140 @ 3600
Net Torque, lb.-ft.247 @ 2000

C/K PICKUP

GVWR SELECTOR—ALL STATES

GVWR Rating (lbs)	†GAWR (lbs)		Minimum Equipment Required for GVW Rating			
			Tire Capacity (lbs ea)		Chassis Equipment	
	Front	Rear	Front	Rear		
C1500 SERIES REGULAR CAB						
◆5200	2904	2904	1452	1452	Standard	
◆5600	2950	3404	1703	1703	Standard	
▲6100	3150	3686	1843	1843	Standard	
C1500 SERIES EXTENDED CAB						
6200	3600	3686	1843	1843	Standard	
K1500 SERIES REGULAR CAB						
◆5600	*3350	3400	1930	1930	Standard	
▲6100	3400	3400	1843	1843	Standard	
K1500 SERIES EXTENDED CAB						
◆6200	3860	3750	2205	2205	Standard	
▲6600	3925	3750	1843	1843	Standard	

†GAWR's shown are the maximum for each axle with equipment listed. Other GAWR's are available, and they are determined as the minimum capacity of either axle, springs or tires.

*3400 for K10903 model.

◆Not available on diesel engine models.

▲Available on 131.5" WB models only.

▲Standard on diesel engine models.

FRONT AND REAR TIRE AVAILABILITY CHART—ALL STATES

C/K1500 SERIES

**Spare tire to match either front or rear tires must be ordered
K1500 models require matching front and rear tread**

Description	Capacity (lbs ea)	Highway		On-Off Road		Spare
		Front	Rear	★Front	Rear	
TUBELESS STEEL BELTED RADIAL						
#P205/75R15	1452	XCE	YCE	—	—	ZCE
#P205/75R15 White Stripe	1452	XCG	YCG	—	—	ZCG
#P225/75R15	1703	XET	YET	—	—	ZET
#P225/75R15 White Stripe	1703	XEU	YEU	—	—	ZEU
#P225/75R15 White Lettered	1703	XEV	YEV	—	—	ZEV
#P235/75R15	1843	XFL	YFL	—	—	ZFL
#P235/75R15 White Stripe	1843	XFM	YFM	—	—	ZFM
#P235/75R15 White Letter	1843	XFN	YFN	—	—	ZFN
★LT225/75R16C	1930	XHE	YHE	—	—	ZHE
★LT225/75R16C White Outline Letter	1930	—	—	XHN	YHN	ZHN
★LT225/75R16C	1930	—	—	XHJ	YHJ	ZHJ
★LT225/75R16C White Stripe	1930	XHV	YHV	—	—	ZHV
●LT245/75R16C	2205	XBK	YBK	—	—	ZBK
●LT245/75R16C White Stripe	2205	XBL	YBL	—	—	ZBL
●LT245/75R16C	2205	—	—	XBN	YBN	ZBN
●LT245/75R16C White Letter	2205	—	—	XBX	YBX	ZBX
◆LT265/75R16C	2470	—	—	XGL	YGL	ZGL
◆LT265/75R16C White Outline Letter	2470	—	—	XGM	YGM	ZGM

#Available on C1500 models only.

★Available on K1500 models only.

●Available on K1500 Extended Cab models only.

◆Available on K1500 models only. Requires Aluminum Wheels.

C/K PICKUP

GVWR SELECTOR—ALL STATES

GVWR Rating (lbs)	†GAWR (lbs)		Minimum Equipment Required for GVW Rating		
	Front	Rear	Tire Capacity (lbs ea)		Chassis Equipment
			Front	Rear	
C2500 SERIES REGULAR CAB					
7200	▲3150	4670	2335	2335	Standard
C2500 SERIES EXTENDED CAB					
7200	3600	4670	2335	2335	Standard
K2500 SERIES REGULAR CAB					
7200	3925	4670	2335	2335	Standard
K2500 SERIES EXTENDED CAB					
7200	3925	4410	2205	2205	Standard

†GAWR's shown are the maximum for each axle with equipment listed. Other GAWR's are available, and they are determined as the minimum capacity of either axle, springs or tires.
 ▲Rated 3400 lbs. for diesel engine models.

FRONT AND REAR TIRE AVAILABILITY CHART—ALL STATES

C/K2500 SERIES

Spare tire to match either front or rear tires is available at extra cost
K2500 models require matching front and rear tread

Description	Capacity (lbs ea)	Highway		On-Off Road		Spare
		Front	Rear	*Front	Rear	
TUBELESS STEEL BELTED RADIAL						
#LT225/75R16D	2335	XHP —	YHP —	— —	— YHR	ZHP ZHR
#LT225/75R15D White Stripe	2335	XHQ	YHQ	—	—	ZHQ
★LT225/75R16D	2335	—	—	XHR	YHR	ZHR
▲LT245/75R16C	2205	XBK	YBK	—	—	ZBK
▲LT245/75R16C White Stripe	2205	XBL	YBL	—	—	ZBL
▲LT245/75R16C	2205	—	—	XBN	YBN	ZBN
▲LT245/75R16C White Outline Letter	2205	—	—	XBX	YBX	ZBX
#LT245/75R16E	3000	XHH —	YHH —	— —	— YGK	ZHH ZGK
★LT245/75R16E	3000	—	—	XGK	YGK	ZGK

#Not available on K20953 Extended Cab models.
 ★ Available on K20903 Regular Cab models only.
 ▲ Available on K20953 Extended Cab models only.

C/K PICKUP GVWR SELECTOR—ALL STATES

GVW Rating (lbs)	†GAWR (lbs)		Minimum Equipment Required for GVW Rating		
	Front	Rear	Tire Capacity (lbs ea)		Chassis Equipment
			Front	Rear	
C3500 SERIES REGULAR CAB					
8600	3800	6000	3000	3000	Standard
10,000	3800	7500	1930	1875 (Duals)	Dual Rear Wheel Provisions (R05)
C3500 SERIES EXTENDED CAB					
8600	3800	6000	3000	3000	Standard
10,000	3800	7500	1930	1875 (Duals)	Dual Rear Wheel Provisions (R05)
K3500 SERIES REGULAR CAB					
8600	4250	6000	3000	3000	Standard
K3500 SERIES EXTENDED CAB					
8600	4250	6000	3000	3000	Standard

†GAWR's shown are the maximum for each axle with equipment listed. Other GAWR's are available, and they are determined as the minimum capacity of either axle, springs or tires.

FRONT AND REAR TIRE AVAILABILITY CHART—ALL STATES

C/K3500 SERIES

Spare tire to match either front or rear tires is available at extra cost
K3500 models require matching front and rear tread

Description	Capacity (lbs each)		Highway			On-Off Road			Spare
	Front/Single Rear	Dual Rear	Front	Single Rear	Dual Rear	†Front	Single Rear	Dual Rear	
TUBELESS Steel Belted Radial									
#LT225/75R16C	1930	—	XHE	—	—	—	—	—	—
LT225/75R16D	—	2150	—	—	YHP	—	—	—	ZHP ZHR
#LT225/75R16D	2335	2150	XHP	—	YHP	—	—	—	ZHP ZHR
#LT225/75R16D White Stripe	2335	2150	XHQ	—	YHQ	—	—	—	ZHQ
#LT225/75R16C White Stripe	1930	—	XHV	—	—	—	—	—	—
#LT225/75R16D White Stripe	—	2150	—	—	YHQ	—	—	—	ZHQ
†LT245/75R16E	3000	3000	—	—	—	XGK	YGK	—	ZGK
LT245/75R16E	3000	3000	XHH	YHH	—	—	—	—	ZHH
#LT245/75R16E	—	—	XHH	—	—	—	YGK	—	ZGK
TUBE-TYPE Nylon									
#7.50-16D	2440	2140	XPF	—	YPF	—	—	—	ZPF

#Available on C3500 models only

†Available on K3500 models only

C/K PICKUP

CAB & BODY FEATURES
CAB CONSTRUCTION
CAB DIMENSIONS
COLOR & TRIM CHARTS
TWO-TONES

C/K PICKUP

CHEYENNE/SIERRA SL FEATURES—STANDARD MODEL

The Cheyenne/Sierra SL standard models include the following items as standard equipment

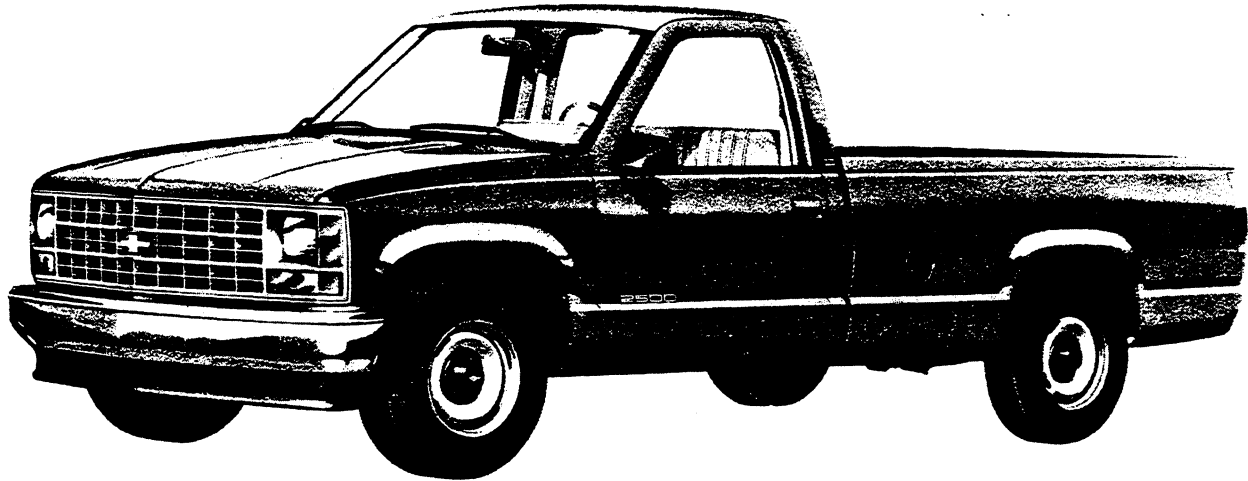

EXTERIOR

- **Bumper:** Front; chromed
- **Color:** See Interior and Exterior Color Selection Chart
- **Grille:** Molded plastic; painted light argent with dark argent air intake areas; Chevrolet emblem/GMC letters at center of grille
- **Horn:** Single, electric, low-note
- **Hub Caps:** Bright metal with black trim (single rear wheel models only)
- **Keys:** Two-key system; with separate keys for ignition switch and door locks
- **Lettering, "Chevrolet/GMC" Tailgate:** Decal with outlined block letters
- **Lights:**
 - Backup lamps: Two rear (integral with tail lamps)
 - Combination parking/direction/hazard: Two front
 - Combination tail/stop/direction/hazard: Two rear
 - Headlamps: Two, rectangular
 - License plate lamp: Single rear
 - Side marker lamps with reflectors: Two front; two rear (integral with tail lamps)
- **Mirrors:** RH and LH fixed arm with adjustable heads; black finish
- **Moldings:** Wheel opening flare moldings (K3500 models only); black with solid color paint, painted lower body color with two-tones
- **Nameplates:** Bright "Cheyenne/Sierra SL" nameplates on upper rear side quarter panel. Series designation nameplates on doors; for 4 wheel drive models, 4x4 decals coordinated with exterior body color at rear of pickup box side panels (located on extension fenders on models with dual rear wheels)
- **Pickup Box:** All-steel double sidewall and tailgate construction; painted body color
- **Spare Tire Carrier:** Winch type mounted under frame at rear
- **Tools:** Mechanical jack and wheel wrench
- **Wheels:** Painted silver with black hub ornament
- **Windshield Wipers and Washers:** Electric, 2-speed wipers with black finish on exposed metal portions; demand-type washer system with fluidic nozzles

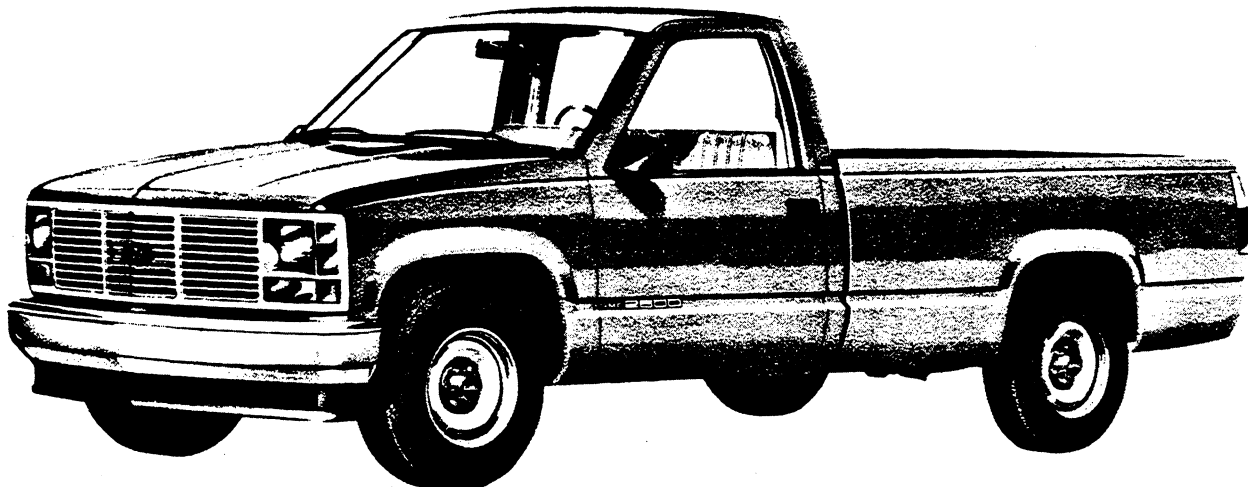

C/K PICKUP

CHEYENNE/SIERRA SL FEATURES—STANDARD MODEL

The Cheyenne/Sierra SL standard models include the following items as standard equipment

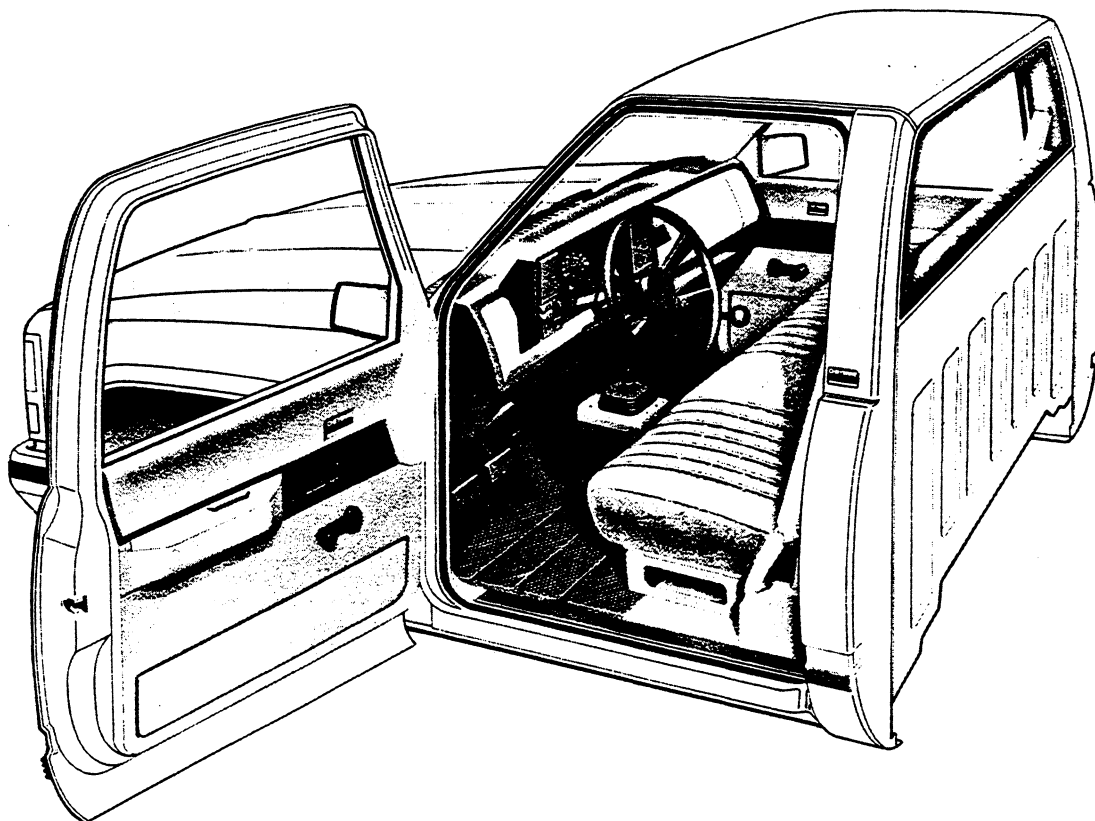

INTERIOR

- **Armrests:** RH and LH; integral with door trim panels
- **Ashtray:** In middle of instrument panel
- **Coat Hooks:** RH (all models) and LH (Extended Cab models)
- **Colors:**
Painted areas: Same as exterior primary color choice
Interior trim: Coordinated with seat trim color choice
- **Door Sill Plates:** Door-opening protection and floor mat retention; full-length; dark gray plastic
- **Door Trim Panels:** Color-keyed, grained molded plastic with integral armrests
- **Dome Lamp:** LH door-operated switch
- **Floor Covering:** Embossed black rubber mats with insulator
- **Glass:** Tinted, all windows (Extended Cabs only)
- **Headliner:** Full length mystic colored vinyl with insulation backing; includes matching retainer moldings
- **Heater and Defogger:** Deluxe-air, with side window defogger
- **Hood Lock Release:** Handle located on LH side under instrument panel
- **Instrument Cluster Bezel:** Black finish
- **Instruments:**
Gages: Speedometer, odometer and fuel
Switches: Main, for control of exterior lights, instrument cluster lights, and cab interior lights; multi-function switch on steering column for direction signals by moving lever up or down (includes lane change position), headlamp beams by pulling lever toward driver, windshield wiper by turning band marked "WIPER" toward or away from driver, and windshield washer by pushing the washer top lever knob; ignition with key-in warning buzzer; hazard warning; heater fan
Warning lights: Generator, oil pressure, engine temperature, service engine soon, seat belt, service-parking brake, direction/hazard signal, and high beam
- **Instrument Panel Pad:** Color-keyed, energy-absorbing foam type with grained vinyl skin
- **Insulation and Sound Deadening Material:** Dash (firewall), under front floor mat, under rear floor mat on Extended Cabs, on Extended Cab rear quarter and cab back panels
- **Lights:** Instrument cluster and cab interior lights
- **Mirror, Rearview:** 10" prismatic with soft vinyl rim
- **Seats:** Regular Cabs—Full width, full depth foam bench-type with embossed, grained, all-vinyl trim and folding backrest. Also available at extra cost: Base cloth bench seat with folding backrest.
Extended Cabs—Full width, full depth foam bench-type with embossed, grained, all-vinyl trim and folding backrest. Also available at extra cost: 1) vinyl split front bench seats with folding backrests and RH easy-entry feature (requires folding rear bench seat); 2) vinyl folding rear bench seat (requires split front bench seat). See Interior and Exterior Color Selection Chart for color and trim availability.
- **Seat Belts:** Front (all models): non-detachable combination lap and shoulder belts for outboard positions with emergency-locking retractors and switch in driver's lap belt retractor for buzzer warning system (RH belt is equipped with child seat restraint feature); lap belt with manual adjustment for center position. Rear (Extended Cabs only): Lap shoulder belt with outboard retractor and locking sliding adjuster. Center lap belt dual retractors for comfort. All rear seating positions can accommodate child seats. All seat belts are color-keyed with push-button type buckles
- **Steering Wheel and Column:** Black, soft plastic wheel with 4 spokes; black energy-absorbing steering column with anti-theft locking feature
- **Storage Box:** In RH side of instrument panel; with beverage holder on inside of door
- **Sunshades:** RH and LH padded; color-keyed
- **Trim Panels:** Cab rear side panels and cab rear upper and lower panels (Extended Cabs only)

C/K PICKUP

SCOTTSDALE/SIERRA SLX MODEL OPTION—RPO Z62 (FOR ALL MODELS)

This option includes all Cheyenne/Sierra SL standard model items plus the additions or substitutions listed below



GMC model shown (Chevrolet model available)

EXTERIOR

- **Bright Appearance Items:** "Scottsdale/Sierra SLX" nameplates on upper rear side quarter panel
- **Bumper Rub Strips:** Black
- **Moldings:** Black plastic body side moldings. Black wheel opening lip moldings (except K3500 models) (Fleetside/Wide-side models with single rear wheels only)

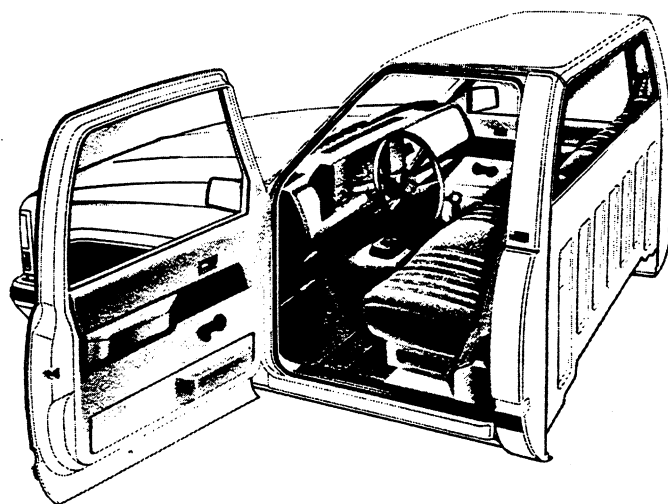

INTERIOR

- **Coat Hooks:** Additional coat hook on LH side
- **Dome Lamp Switch:** In RH door jamb
- **Door Sill Plates:** Color-keyed
- **Door Trim Panels:** Color-keyed grained molded plastic, with soft vinyl trim, map pocket, integral armrests and Scottsdale/Sierra SLX emblems
- **Floor Covering:** Color-keyed rubber mats
- **Headliner:** Full-length color-keyed cloth with insulation backing; includes matching retainer moldings (Regular cabs only)
- **Pillar Trim Panels:** Color-keyed molded plastic on door pillars and roof side
- **Seats:**
 - Regular Cabs—Standard cloth bench seat. Also available at extra cost: 1) Custom vinyl bench seat and 2) Custom vinyl bucket seats
 - Extended Cabs—Custom vinyl bench seat. Also available at extra cost: 1) Custom vinyl split front bench seat with RH easy-entry feature; 2) Custom vinyl front bucket seats with RH easy-entry feature; 3) Custom vinyl rear folding bench seatSee Interior and Exterior Color Selection Chart for color and trim availability.
- **Storage Tray:** Full width on floor behind seat
- **Trim Panels:** (Regular Cab only) Cab rear side panels and cab rear upper and lower panels

C/K PICKUP

SILVERADO/SIERRA SLE MODEL OPTION—RPO YE9

This option includes all items in the Scottsdale/Sierra SLX model option plus the additions or substitutions listed below

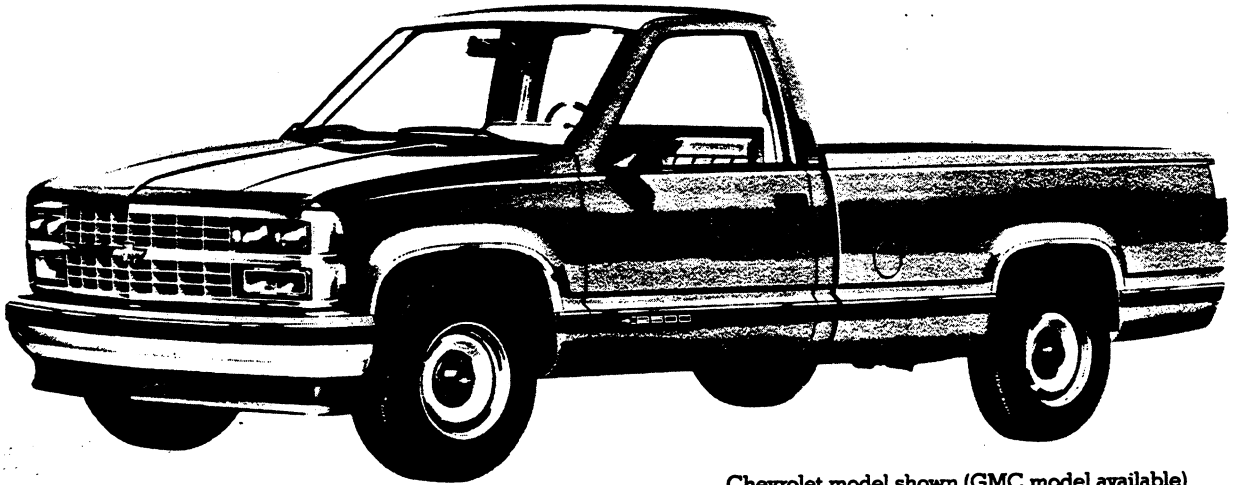

Chevrolet model shown (GMC model available)

EXTERIOR

- **Bright Appearance Items:**

- "Silverado/Sierra SLE" nameplates on upper rear side quarter panels
- Chrome-trimmed grille
- "Chevrolet/GMC" letters nameplate on tailgate applique panel (Fleetside/Wideside only)
- Bright applique panel fitted over central area of tailgate (Fleetside/Wideside only)

- Wheel-opening lip moldings (except K3 models) (Fleetside/Wideside models with single rear wheels only)
- **Bumper Rub Strips:** Black with bright trim
- **Cab-to-Fender Insulators:** Gasoline models only
- **Hood Insulator**
- **Horn:** Additional, electric, high note
- **Moldings:** Black body side with bright trim
- **Special Headlamps:** Halogen, rectangular; dual RH and LH

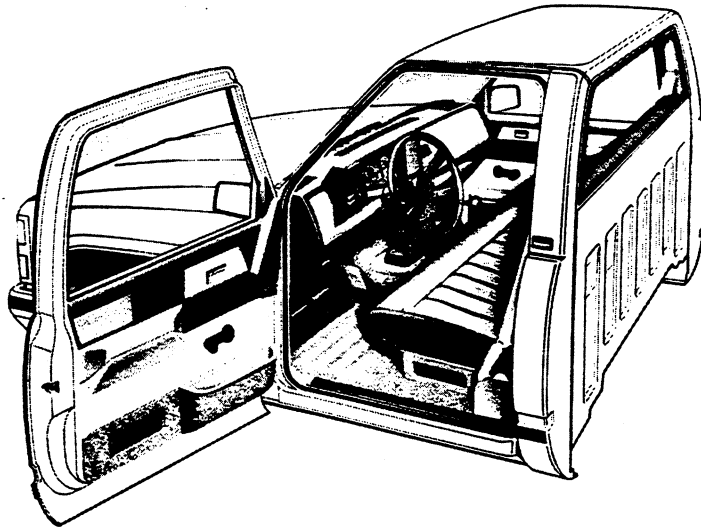

INTERIOR

- **Cab-to-Fender Insulators**
- **Cigarette Lighter:** In ashtray
- **Cowl Panel Trim:** Color-keyed carpet on cowl side panels with insulator
- **Door Trim Panels:** Two-tone soft vinyl over plastic with integral armrests, map pocket, door closing assist straps, and Silverado/SLE emblems
- **Floor Covering:** Color-keyed carpeting and sill plates
- **Instrument Cluster:** Voltmeter, engine temperature, and oil pressure gauges replace warning lights
- **Hood Insulator**
- **Insulation:** On cab back panel
- **Seats:**
Regular Cabs—Choice of Custom Vinyl or Custom Cloth bench

seat. Also available at extra cost: Custom vinyl or custom cloth front bucket seats

Extended Cabs—Choice of Custom Vinyl or Custom Cloth split front bench seat with RH easy-entry feature. Also available at extra cost: 1) Custom vinyl or custom cloth front bucket seats with RH easy-entry feature; and 2) Matching Custom Vinyl or Custom Cloth rear folding bench seat.

See Interior and Exterior Color Selection Chart for color and trim availability

- **Steering Wheel:** Custom 4-spoke
- **Sunshades:** RH & LH cloth covered with storage strap on LH unit
- **Trim Panels:** Color-keyed carpet on cab back panel
- **Visor Mirror:** On RH sun visor

C/K REGULAR CAB PICKUP

INTERIOR AND EXTERIOR COLOR AVAILABILITY CHART

WITH ZY1 AND ZY2 PAINT

PLEASE NOTE: Below are the interior trim color and exterior paint combinations recommended by Chevrolet/GMC. They are the only available interior and exterior combinations allowed.

TRIM LEVEL Seat Type		INTERIOR COLORS						D85 STRIPING CHART RECOMMENDED COMBINATIONS STRIPE COLORS					
		Decor	Beige	Blue	Garnet	Gray	Saddle						
CHEYENNE/SIERRA SL Vinyl Bench Seat		STD	VUU1	VDD1	VRR1	VQQ1	VSS1						
Cloth Bench Seat			CUU1	CDD1	CRR1	CQQ1	CSS1						
SCOTTSDALE/SIERRA SLX Cloth Bench Seat		Z62	CUU1	CDD1	CRR1	CQQ1	CSS1						
Custom Vinyl Bench Seat			XUU1	XDD1	XRR1	XQQ1	XSS1						
Custom Vinyl Bucket Seat				XDD2	XRR2		XSS2						
SILVERADO/SIERRA SLE Custom Cloth Bench Seat		YE9	LUU1	LDD1	LRR1	LQQ1	LSS1						
Custom Vinyl Bench Seat			XUU1	XDD1	XRR1	XQQ1	XSS1						
Custom Cloth Bucket Seat				LDD2	LRR2	LQQ2	LSS2						
Custom Vinyl Bucket Seat				XDD2	XRR2		XSS2						
EXTERIOR COLORS w/ZY1 & ZY2 PAINT	Color Code 1	Color Code 2	INTERIOR & EXTERIOR COMBINATIONS SHOWN ARE THE ONLY COMBINATIONS AVAILABLE				DK BLUE	DK BROWN	COPPER BEIGE	GOLD	SILVER	VERMILLION	
BLACK, SABLE (METALLIC)	18	18		●		●				●			
BLACK, SABLE (METALLIC)	18	18				●			●		●		
BLACK, SABLE (METALLIC)	18	18				●			●		●		
BLACK, SABLE (METALLIC)	18	18	●					●					
Gold, Adobe (Metallic)*	18	52				●			●				
Quicksilver (Metallic)	18	96				●			●				
Red, Flame*	18	70				●			●		●		
BLUE, ICED (METALLIC)	22	22		●		●				●			
Blue, Pacific (Metallic)	22	30		●		●			●				
Quicksilver (Metallic)	22	96		●		●			●				
White, Summit*	22	50		●		●			●				
BLUE, PACIFIC (METALLIC)	30	30		●		●			●		●		
BLUE, PACIFIC (METALLIC)	30	30				●			●				
Blue, Iced (Metallic)*	30	22		●		●			●				
Quicksilver (Metallic)	30	96		●		●			●				
White, Summit*	30	50		●		●			●				
White, Summit*	30	50				●			●				
BRANDYWINE (METALLIC)	95	95				●			●				
BRANDYWINE (METALLIC)	95	95				●			●				
Black, Sable (Metallic)	95	18				●			●				
Quicksilver (Metallic)	95	96				●			●				
White, Summit*	95	50				●			●				
BROWN, SPICE (METALLIC)	32	32	●			●			●				
Gold, Adobe (Metallic)*	32	52	●			●			●				
Sandstone (Metallic)*	32	58	●			●			●				
GOLD, ADOBE (METALLIC)	52	52	●			●			●				
Black, Sable (Metallic)	52	18				●			●				
Brown, Spice (Metallic)	52	32	●			●			●				
QUICKSILVER (METALLIC)	96	96		●	●	●			●		●		
Black, Sable (Metallic)	96	18				●			●				
Blue, Pacific (Metallic)	96	30		●		●	●		●				
Blue, Iced (Metallic)*	96	22		●		●	●		●				
Brandywine (Metallic)	96	95				●			●		●		
Red, Flame*	96	70				●			●		●		
RED, FLAME	70	70				●			●		●		
Black, Sable (Metallic)	70	18				●			●				
Black, Sable (Metallic)	70	18				●			●				
Quicksilver (Metallic)	70	96				●			●				
Quicksilver (Metallic)	70	96				●			●				
White, Summit*	70	50				●			●				
White, Summit*	70	50				●			●				
SANDSTONE (METALLIC)	58	58				●			●				
SANDSTONE (METALLIC)	58	58	●			●			●				
Black, Sable (Metallic)	58	18				●			●				
Brown, Spice (Metallic)	58	32	●			●			●				
WHITE, SUMMIT	50	50		●		●			●				
WHITE, SUMMIT	50	50	●			●			●				
WHITE, SUMMIT	50	50				●			●				
Blue, Pacific (Metallic)	50	30		●		●	●		●				
Blue, Iced (Metallic)*	50	22		●		●	●		●				
Brandywine (Metallic)	50	95				●			●		●		
Brown, Spice (Metallic)	50	32				●			●				
Quicksilver (Metallic)	50	96				●			●				
Red, Flame*	50	70				●			●		●		

*N/A K3500 models

C/K EXTENDED CAB PICKUP

INTERIOR AND EXTERIOR COLOR AVAILABILITY CHART

WITH ZY1 AND ZY2 PAINT

PLEASE NOTE: Below are the interior trim color and exterior paint combinations recommended by Chevrolet/GMC. They are the only available interior and exterior combinations allowed.

TRIM LEVEL		INTERIOR COLORS									
Seat Type	Decor	Blue	Garnet	Saddle							
CHEYENNE/SIERRA SL		STD									
Vinyl Bench Seat			VDD1	VRR1	VSS1						
Cloth Bench Seat			CDD1	CRR1	CSS1						
#Vinyl Split Bench Seat			VDD3	VRR3	VSS3						
#Cloth Split Bench Seat			CDD3	CRR3	CSS3						
SCOTTSDALE/SIERRA SLX		Z62									
Cloth Bench Seat			CDD1	CRR1	CSS1						
Custom Vinyl Bench Seat			XDD1	XRR1	XSS1						
#Cloth Split Bench Seat			CDD3	CRR3	CSS3						
#Custom Vinyl Split Bench Seat			XDD3	XRR3	XSS3						
#Custom Vinyl Bucket Seat		XDD2	XRR2	XSS2							
SILVERADO/SIERRA SLE		YE9									
#Custom Cloth Split Bench Seat			LDD3	LRR3	LSS3						
#Custom Vinyl Split Bench Seat			XDD3	XRR3	XSS3						
#Custom Cloth Bucket Seat			LDD2	LRR2	LSS2						
#Custom Vinyl Bucket Seat			XDD2	XRR2	XSS2						
		D85 STRIPING CHART									
		RECOMMENDED COMBINATIONS									
		STRIPE COLORS									
EXTERIOR COLORS w/ZY1 & ZY2 PAINT	Color Code 1	Color Code 2	INTERIOR & EXTERIOR COMBINATIONS SHOWN ARE THE ONLY COMBINATIONS AVAILABLE			DK BLUE	DK BROWN	COPPER BEIGE	GOLD	SILVER	VERMILLION
BLACK, SABLE (METALLIC)	18	18	●								
BLACK, SABLE (METALLIC)	18	18		●							
BLACK, SABLE (METALLIC)	18	18			●						
Gold, Adobe (Metallic)*	18	52			●						
Red, Flame*	18	70		●							
BLUE, ICED (METALLIC)	22	22	●								
Blue, Pacific (Metallic)	22	30	●								
Quicksilver (Metallic)	22	96	●								
White, Summit*	22	50	●								
BLUE, PACIFIC (METALLIC)	30	30	●								
BLUE, PACIFIC (METALLIC)	30	30		●							
Blue, Iced (Metallic)*	30	22	●								
Quicksilver (Metallic)	30	96	●								
White, Summit*	30	50	●								
White, Summit*	30	50			●						
BRANDYWINE (METALLIC)	95	95		●							
BRANDYWINE (METALLIC)	95	95			●						
Black, Sable (Metallic)	95	18		●							
Quicksilver (Metallic)	95	96		●							
White, Summit*	95	50		●							
BROWN, SPICE (METALLIC)	32	32			●						
Gold, Adobe (Metallic)*	32	52			●						
GOLD, ADOBE (METALLIC)	52	52			●						
Black, Sable (Metallic)	52	18		●							
QUICKSILVER, (METALLIC)	96	96	●								
Blue, Pacific (Metallic)	96	30	●								
Blue, Iced (Metallic)*	96	22	●								
Brandywine, (Metallic)	96	95		●							
Red, Flame*	96	70		●							
RED, FLAME	70	70			●						
Black, Sable (Metallic)	70	18		●							
Black, Sable (Metallic)	70	18			●						
Quicksilver, (Metallic)	70	96		●							
Quicksilver, (Metallic)	70	96			●						
White, Summit*	70	50		●							
White, Summit*	70	50			●						
SANDSTONE (METALLIC)	58	58			●						
Brown, Spice (Metallic)	58	32			●						
WHITE, SUMMIT	50	50	●								
WHITE, SUMMIT	50	50		●							
WHITE, SUMMIT	50	50			●						
Blue, Pacific (Metallic)	50	30	●								
Blue, Iced (Metallic)*	50	22	●								
Brandywine, (Metallic)	50	95		●							
Brown, Spice (Metallic)	50	32			●						
Quicksilver, (Metallic)	50	96		●							
Red, Flame*	50	70		●							

*N/A K3500 models
#Requires AM7 Folding Rear Seat

C/K REGULAR CAB PICKUP

INTERIOR AND EXTERIOR COLOR AVAILABILITY CHART

C/K1500-2500 AND C3500 MODELS ONLY

WITH ZY3 AND ZY4 PAINT

PLEASE NOTE: Below are the interior trim color and exterior paint combinations recommended by Chevrolet/GMC. They are the only available interior and exterior combinations allowed.

TRIM LEVEL		Decor	INTERIOR COLORS					STRIPE COLOR	
Seat Type			Beige	Blue	Garnet	Gray	Saddle		
CHEYENNE/SIERRA SL		STD	VUU1	VDD1	VRR1	VQQ1	VSS1		
Vinyl Bench Seat			CUU1	CDD1	CRR1	COQ1	CSS1		
Cloth Bench Seat									
SCOTSDALE/SIERRA SLX		Z62	CUU1	CDD1	CRR1	COQ1	CSS1		
Cloth Bench Seat			XUU1	XDD1	XRR1	XQQ1	XSS1		
Custom Vinyl Bench Seat				XDD2	XRR2		XSS2		
Custom Vinyl Bucket Seat									
SILVERADO/SIERRA SLE		YE9	LUU1	LDD1	LRR1	LQQ1	LSS1		
Custom Cloth Bench Seat			XUU1	XDD1	XRR1	XQQ1	XSS1		
Custom Vinyl Bench Seat				LDD2	LRR2	LQQ2	LSS2		
Custom Cloth Bucket Seat				XDD2	XRR2		XSS2		
Custom Vinyl Bucket Seat									
EXTERIOR COLORS w/ZY3, & ZY4 PAINT		Color Code 1	Color Code 2	INTERIOR & EXTERIOR COMBINATIONS SHOWN ARE THE ONLY COMBINATIONS AVAILABLE					STRIPE COLOR
BLACK, SABLE (Metallic)/ Gold, Adobe (Metallic)		18	52						Gold/Black
BLACK, SABLE (Metallic)/ Red, Flame		18	70						Vermillion/Dark Red
BLACK, SABLE (Metallic)/Quicksilver		18	96						Vermillion/Silver
BLUE, ICED (Metallic)/ Blue, Pacific (Metallic)		22	30						Light Blue/Dark Blue
BLUE, ICED (Metallic)/ Quicksilver (Metallic)		22	96						Light Blue/Dark Blue
BLUE, ICED (Metallic)/ White, Summit		22	50						Light Blue/Dark Blue
BLUE, PACIFIC (Metallic)/ Blue, Iced (Metallic)		30	22						Light Blue/Dark Blue
BLUE, PACIFIC (Metallic)/ Quicksilver (Metallic)		30	96						Vermillion/Silver
BLUE, PACIFIC (Metallic)/ White, Summit		30	50						Light Blue/Dark Blue
BLUE, PACIFIC (Metallic)/ White, Summit		30	50						Gold/Black
BRANDYWINE/Black, Sable (Metallic)		95	18						Vermillion/Dark Red
BRANDYWINE/Quicksilver (Metallic)		95	96						Vermillion/Silver
BRANDYWINE/White, Summit		95	50						Vermillion/Dark Red
BROWN, SPICE (Metallic)/ Gold, Adobe (Metallic)		32	52						Doeskin/Carmine
BROWN, SPICE (Metallic)/ Sandstone (Metallic)		32	58						Doeskin/Carmine
GOLD, ADOBE (Metallic)/ Black, Sable (Metallic)		52	18						Doeskin/Carmine
GOLD, ADOBE (Metallic)/ Brown, Spice (Metallic)		52	32						Doeskin/Carmine
QUICKSILVER (Metallic)/ Black, Sable (Metallic)		96	18						Vermillion/Silver
QUICKSILVER (Metallic)/ Blue, Pacific (Metallic)		96	30						Light Blue/Dark Blue
QUICKSILVER (Metallic)/ Blue, Iced (Metallic)		96	22						Light Blue/Dark Blue
QUICKSILVER (Metallic)/ Brandywine (Metallic)		96	95						Vermillion/Silver
QUICKSILVER (Metallic)/ Red, Flame		96	70						Vermillion/Silver
RED, FLAME/Black, Sable		70	18						Gold/Black
RED, FLAME/Black, Sable		70	18						Vermillion/Dark Red
RED, FLAME/Quicksilver (Metallic)		70	96						Vermillion/Dark Red
RED, FLAME/Quicksilver (Metallic)		70	96						Vermillion/Silver
RED, FLAME/White, Summit		70	50						Vermillion/Dark Red
RED, FLAME/White, Summit		70	50						Gold/Black
SANDSTONE (Metallic)/ Black, Sable (Metallic)		58	18						Doeskin/Carmine
SANDSTONE (Metallic)/ Brown, Spice (Metallic)		58	32						Doeskin/Carmine
WHITE, SUMMIT/Blue Pacific (Metallic)		50	30						Light Blue/Dark Blue
WHITE, SUMMIT/Blue, Iced (Metallic)		50	22						Light Blue/Dark Blue
WHITE, SUMMIT/Brown, Spice (Metallic)		50	32						Doeskin/Carmine
WHITE, SUMMIT/Brandywine (Metallic)		50	95						Vermillion/Dark Red
WHITE, SUMMIT/Red, Flame		50	70						Vermillion/Silver
WHITE, SUMMIT/Quicksilver (Metallic)		50	96						Vermillion/Silver

C/K EXTENDED CAB PICKUP
INTERIOR AND EXTERIOR COLOR AVAILABILITY CHART
C/K1500-2500 AND C3500 MODELS ONLY
WITH ZY3 AND ZY4 PAINT

PLEASE NOTE: Below are the interior trim color and exterior paint combinations recommended by Chevrolet/GMC. They are the only available interior and exterior combinations allowed.

TRIM LEVEL		Decor	INTERIOR COLORS			STRIPE COLOR
Seat Type			Blue	Garnet	Saddle	
CHEYENNE/SIERRA SL		STD				
Vinyl Bench Seat			VDD1	VRR1	VSS1	
Cloth Bench Seat			CDD1	CRR1	CSS1	
#Vinyl Split Bench Seat			VDD3	VRR3	VSS3	
#Cloth Split Bench Seat			CDD3	CRR3	CSS3	
SCOTTSDALE/SIERRA SLX		Z62				
Cloth Bench Seat			CDD1	CRR1	CSS1	
Custom Vinyl Bench Seat			XDD1	XRR1	XSS1	
#Cloth Split Bench Seat			CDD3	CRR3	CSS3	
#Custom Vinyl Split Bench Seat			XDD3	XRR3	XSS3	
#Custom Vinyl Bucket Seat		XDD2	XRR2	XSS2		
SILVERADO/SIERRA SLE		YE9				
#Custom Cloth Split Bench Seat			LDD3	LRR3	LSS3	
#Custom Vinyl Split Bench Seat			XDD3	XRR3	XSS3	
#Custom Cloth Bucket Seat			LDD2	LRR2	LSS2	
#Custom Vinyl Bucket Seat			XDD2	XRR2	XSS2	
EXTERIOR COLORS w/ZY3, & ZY4 PAINT		Color Code 1	Color Code 2	INTERIOR & EXTERIOR COMBINATIONS SHOWN ARE THE ONLY COMBINATIONS AVAILABLE		STRIPE COLOR
BLACK, SABLE (Metallic)/ Gold, Adobe (Metallic)	18	52			●	Gold/Black
BLACK, SABLE (Metallic)/ Red, Flame	18	70		●		Vermillion/Dark Red
BLUE, ICED (Metallic)/ Blue, Pacific (Metallic)	22	30	●			Light Blue/Dark Blue
BLUE, ICED (Metallic)/ Quicksilver (Metallic)	22	96	●			Light Blue/Dark Blue
BLUE, ICED (Metallic)/ White, Summit	22	50	●			Light Blue/Dark Blue
BLUE, PACIFIC (Metallic)/ Blue, Iced (Metallic)	30	22	●			Light Blue/Dark Blue
BLUE, PACIFIC (Metallic)/ Quicksilver, (Metallic)	30	96	●			Vermillion/Silver
BLUE, PACIFIC (Metallic)/ White, Summit	30	50	●			Light Blue/Dark Blue
BLUE, PACIFIC (Metallic)/ White, Summit	30	50			●	Gold/Black
BRANDYWINE/Black, Sable (Metallic)	95	18		●		Vermillion/Dark Red
BRANDYWINE/Quicksilver (Metallic)	95	96		●		Vermillion/Silver
BRANDYWINE/White, Summit	95	50		●		Vermillion/Dark Red
BROWN, SPICE (Metallic)/ Gold, Adobe (Metallic)	32	52			●	Doeskin/Carmine
GOLD, ADOBE (Metallic)/ Black, Sable (Metallic)	52	18			●	Doeskin/Carmine
QUICKSILVER (Metallic)/ Blue, Pacific (Metallic)	96	30	●			Light Blue/Dark Blue
QUICKSILVER (Metallic)/ Blue, Iced (Metallic)	96	22	●			Light Blue/Dark Blue
QUICKSILVER (Metallic)/ Brandywine (Metallic)	96	95		●		Vermillion/Silver
QUICKSILVER (Metallic)/ Red, Flame	96	70		●		Vermillion/Silver
RED, FLAME/Black, Sable	70	18			●	Gold/Black
RED, FLAME/Black, Sable	70	18		●		Vermillion/Dark Red
RED, FLAME/Quicksilver (Metallic)	70	96		●		Vermillion/Dark Red
RED, FLAME/Quicksilver (Metallic)	70	96			●	Vermillion/Silver
RED, FLAME/White, Summit	70	50		●		Vermillion/Dark Red
RED, FLAME/White, Summit	70	50			●	Gold/Black
SANDSTONE (Metallic)/ Brown, Spice (Metallic)	58	32			●	Doeskin/Carmine
WHITE, SUMMIT/Blue Pacific (Metallic)	50	30	●			Light Blue/Dark Blue
WHITE, SUMMIT/Blue, Iced (Metallic)	50	22	●			Light Blue/Dark Blue
WHITE, SUMMIT/Brown, Spice (Metallic)	50	32			●	Doeskin/Carmine
WHITE, SUMMIT/Brandywine (Metallic)	50	95		●		Vermillion/Dark Red
WHITE, SUMMIT/Red, Flame	50	70		●		Vermillion/Silver
WHITE, SUMMIT/Quicksilver (Metallic)	50	96		●		Vermillion/Silver

#Requires AM7 Folding Rear Seat

C/K REGULAR CAB PICKUP

INTERIOR AND EXTERIOR COLOR AVAILABILITY CHART

K3500 MODEL ONLY

WITH ZY3 AND ZY4 PAINT

PLEASE NOTE: Below are the interior trim color and exterior paint combinations recommended by Chevrolet/GMC. They are the only available interior and exterior combinations allowed.

TRIM LEVEL			Decor	INTERIOR COLORS					STRIPE COLOR
Seat Type				Beige	Blue	Garnet	Gray	Saddle	
CHEYENNE/SIERRA SL			STD	VUU1	VDD1	VRR1	VQQ1	VSS1	
Vinyl Bench Seat				CUU1	CDD1	CRR1	COQ1	CSS1	
Cloth Bench Seat									
SCOTTSDALE/SIERRA SLX			Z62	CUU1	CDD1	CRR1	COQ1	CSS1	
Cloth Bench Seat				XUU1	XDD1	XRR1	XQQ1	XSS1	
Custom Vinyl Bench Seat				XUU1	XDD2	XRR2	XQQ1	XSS2	
Custom Vinyl Bucket Seat									
SILVERADO/SIERRA SLE			YE9	LUU1	LDD1	LRR1	LOQ1	LSS1	
Custom Cloth Bench Seat				XUU1	XDD1	XRR1	XQQ1	XSS1	
Custom Vinyl Bench Seat				XUU1	XDD1	XRR1	XQQ1	XSS1	
Custom Cloth Bucket Seat				LDD2	LRR2	LOQ2	LSS2		
Custom Vinyl Bucket Seat				XDD2	XRR2	LOQ2	XSS2		
EXTERIOR COLORS w/ZY3 & ZY4 PAINT	Two-Tone Available	Color Code 1	Color Code 2	INTERIOR & EXTERIOR COMBINATIONS SHOWN ARE THE ONLY COMBINATIONS AVAILABLE					STRIPE COLOR
BLACK, SABLE (Metallic)/ Gold, Adobe (Metallic)	ZY4 only	18	52						Gold/Black
BLACK, SABLE (Metallic)/ Quicksilver	All	18	96						Vermillion/Silver
BLACK, SABLE (Metallic)/ Red, Flame	ZY4 only	18	70						Vermillion/Dark Red
BLUE, ICED (Metallic)/ Blue, Pacific (Metallic)	ZY3 only	22	30						Light Blue/Dark Blue
BLUE, ICED (Metallic)/ Quicksilver (Metallic)	ZY3 only	22	96						Light Blue/Dark Blue
BLUE, PACIFIC (Metallic)/ Blue, Iced (Metallic)	ZY4 only	30	22						Light Blue/Dark Blue
BLUE, PACIFIC (Metallic)/ Quicksilver (Metallic)	All	30	96						Vermillion/Silver
BLUE, PACIFIC (Metallic)/ White, Summit	ZY4 only	30	50						Light Blue/Dark Blue
BLUE, PACIFIC (Metallic)/ White, Summit	ZY4 only	30	50						Gold/Black
BRANDYWINE/ Black, Sable (Metallic)	All	95	18						Vermillion/Dark Red
BRANDYWINE/ Quicksilver (Metallic)	All	95	96						Vermillion/Silver
BRANDYWINE/White, Summit	ZY4 only	95	50						Vermillion/Dark Red
BROWN, SPICE (Metallic)/ Gold, Adobe (Metallic)	ZY4 only	32	52						Doeskin/Carmine
BROWN, SPICE (Metallic)/ Sandstone (Metallic)	ZY4 only	32	58						Doeskin/Carmine
GOLD, ADOBE (Metallic)/ Black, Sable (Metallic)	ZY3 only	52	18						Doeskin/Carmine
GOLD, ADOBE (Metallic)/ Brown, Spice (Metallic)	ZY3 only	52	32						Doeskin/Carmine
QUICKSILVER (Metallic)/ Black, Sable (Metallic)	All	96	18						Vermillion/Silver
QUICKSILVER (Metallic)/ Blue, Iced (Metallic)	ZY4 only	96	22						Light Blue/Dark Blue
QUICKSILVER (Metallic)/ Blue, Pacific (Metallic)	All	96	30						Light Blue/Dark Blue
QUICKSILVER (Metallic)/ Brandywine (Metallic)	All	96	95						Vermillion/Silver
QUICKSILVER (Metallic)/ Red, Flame	ZY4 only	96	70						Vermillion/Silver
RED, FLAME/Black, Sable	ZY3 only	70	18						Gold/Black
RED, FLAME/Black, Sable	ZY3 only	70	18						Vermillion/Dark Red
RED, FLAME/ Quicksilver (Metallic)	ZY3 only	70	96						Vermillion/Dark Red
RED, FLAME/ Quicksilver (Metallic)	ZY3 only	70	96						Vermillion/Silver
SANDSTONE (Metallic)/ Black, Sable (Metallic)	ZY3 only	58	18						Doeskin/Carmine
SANDSTONE (Metallic)/ Brown, Spice (Metallic)	ZY3 only	58	32						Doeskin/Carmine
WHITE, SUMMIT/ Blue Pacific (Metallic)	ZY3 only	50	30						Light Blue/Dark Blue
WHITE, SUMMIT/ Brown, Spice (Metallic)	ZY3 only	50	32						Doeskin/Carmine
WHITE, SUMMIT/ Brandywine (Metallic)	ZY3 only	50	95						Vermillion/Dark Red
WHITE, SUMMIT/ Quicksilver (Metallic)	ZY3 only	50	96						Vermillion/Silver

C/K EXTENDED CAB PICKUP
INTERIOR AND EXTERIOR COLOR AVAILABILITY CHART
K3500 MODELS ONLY
WITH ZY3 AND ZY4 PAINT

PLEASE NOTE: Below are the interior trim color and exterior paint combinations recommended by Chevrolet/GMC. They are the only available interior and exterior combinations allowed.

TRIM LEVEL Seat Type	Decor	INTERIOR COLORS					
		Blue	Garnet	Saddle			
CHEYENNE/SIERRA SL Vinyl Bench Seat	STD	VDD1	VRR1	VSS1			
Cloth Bench Seat		CDD1	CRR1	CSS1			
#Vinyl Split Bench Seat		VDD3	VRR3	VSS3			
#Cloth Split Bench Seat		CDD3	CRR3	CSS3			
SCOTTSDALE/SIERRA SLX Cloth Bench Seat	Z62	CDD1	CRR1	CSS1			
Custom Vinyl Bench Seat		XDD1	XRR1	XSS1			
#Cloth Split Bench Seat		CDD3	CRR3	CSS3			
#Custom Vinyl Split Bench Seat		XDD3	XRR3	XSS3			
#Custom Vinyl Bucket Seat		XDD2	XRR2	XSS2			
SILVERADO/SIERRA SLE #Custom Cloth Split Bench Seat	YE9	LDD3	LRR3	LSS3			
#Custom Vinyl Split Bench Seat		XDD3	XRR3	XSS3			
#Custom Cloth Bucket Seat		LDD2	LRR2	LSS2			
#Custom Vinyl Bucket Seat		XDD2	XRR2	XSS2			
EXTERIOR COLORS w/ZY3, & ZY4 PAINT	Two-Tone Available	Color Code 1	Color Code 2	INTERIOR & EXTERIOR COMBINATIONS SHOWN ARE THE ONLY COMBINATIONS AVAILABLE			STRIPE COLOR
BLACK, SABLE (Metallic)/Gold, Adobe (Metallic)	ZY4 only	18	52	●	●	●	Gold/Black
BLACK, SABLE (Metallic)/Red, Flame	ZY4 only	18	70	●	●	●	Vermillion/Dark Red
BLUE, ICED (Metallic)/Blue, Pacific (Metallic)	ZY3 only	22	30	●	●	●	Light Blue/Dark Blue
BLUE, ICED (Metallic)/Quicksilver (Metallic)	ZY3 only	22	96	●	●	●	Light Blue/Dark Blue
BLUE, PACIFIC (Metallic)/Blue, Iced (Metallic)	ZY4 only	30	22	●	●	●	Light Blue/Dark Blue
BLUE, PACIFIC (Metallic)/Quicksilver, (Metallic)	All	30	96	●	●	●	Vermillion/Silver
BLUE, PACIFIC (Metallic)/White, Summit	ZY4 only	30	50	●	●	●	Light Blue/Dark Blue
BLUE, PACIFIC (Metallic)/White, Summit	ZY4 only	30	50	●	●	●	Gold/Black
BRANDYWINE/Black, Sable (Metallic)	All	95	18	●	●	●	Vermillion/Dark Red
BRANDYWINE/Quicksilver (Metallic)	All	95	96	●	●	●	Vermillion/Silver
BRANDYWINE/White, Summit	ZY4 only	95	50	●	●	●	Vermillion/Dark Red
BROWN, SPICE (Metallic)/Gold, Adobe (Metallic)	ZY4 only	32	52	●	●	●	Doeskin/Carmine
GOLD, ADOBE (Metallic)/Black, Sable (Metallic)	ZY3 only	52	18	●	●	●	Doeskin/Carmine
QUICKSILVER (Metallic)/Blue, Iced (Metallic)	ZY4 only	96	22	●	●	●	Light Blue/Dark Blue
QUICKSILVER (Metallic)/Blue, Pacific (Metallic)	All	96	30	●	●	●	Light Blue/Dark Blue
QUICKSILVER (Metallic)/Brandywine (Metallic)	All	96	95	●	●	●	Vermillion/Silver
QUICKSILVER (Metallic)/Red, Flame	ZY4 only	96	70	●	●	●	Vermillion/Silver
RED, FLAME/Black, Sable	ZY3 only	70	18	●	●	●	Gold/Black
RED, FLAME/Black, Sable	ZY3 only	70	18	●	●	●	Vermillion/Dark Red
RED, FLAME/Quicksilver (Metallic)	ZY3 only	70	96	●	●	●	Vermillion/Dark Red
RED, FLAME/Quicksilver (Metallic)	ZY3 only	70	96	●	●	●	Vermillion/Silver
SANDSTONE (Metallic)/Brown, Spice (Metallic)	ZY3 only	58	32	●	●	●	Doeskin/Carmine
WHITE, SUMMIT/Blue, Pacific (Metallic)	ZY3 only	50	30	●	●	●	Light Blue/Dark Blue
WHITE, SUMMIT/Brandywine (Metallic)	ZY3 only	50	95	●	●	●	Vermillion/Dark Red
WHITE, SUMMIT/Brown, Spice (Metallic)	ZY3 only	50	32	●	●	●	Doeskin/Carmine
WHITE, SUMMIT/Quicksilver (Metallic)	ZY3 only	50	96	●	●	●	Vermillion/Silver

#Requires AM7 Folding Rear Seat.

C/K PICKUP

SOLID AND TWO-TONE* EXTERIOR COLOR COMBINATIONS

The application of paint for solid and two-tone exterior color combinations is shown below.

Solid color paint (ZY1) is standard on all models. All painted areas of the cab, front end sheet metal, and box are the same color. Outlined block "Chevrolet/GMC" decal lettering is applied to the tailgate. (A bright trim plate with lettering is applied on Fleetside/Wideside models when the Silverado/Sierra SLX Model Option is ordered.)

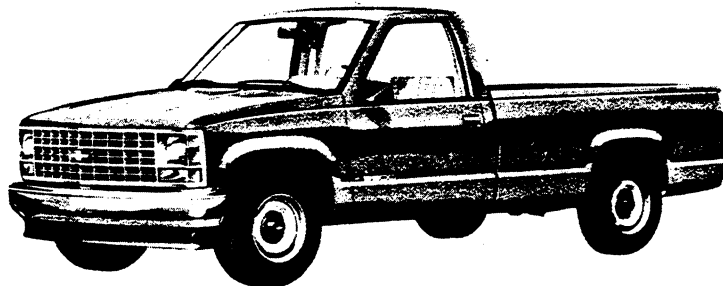

Conventional two-tone (ZY2) paint colors are available only on single rear wheel Fleetside/Wideside Pickup models. Color code 1 is applied to the areas above the lower styling crease line (including the cab roof). Color code 2 is applied to the areas below. Outlined block "Chevrolet/GMC" decal lettering is applied to the tailgate. (A bright trim plate with lettering is applied on Fleetside/Wideside models when the Silverado/Sierra SLX Model Option is ordered.)

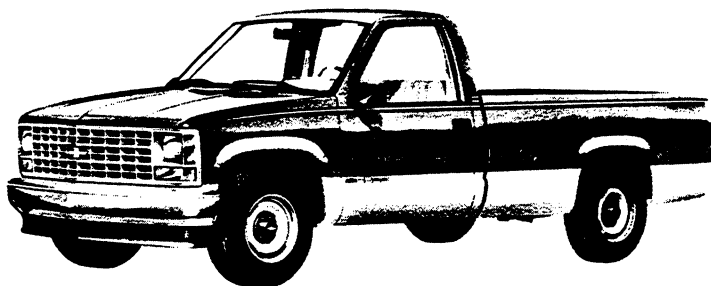

Special two-tone (ZY3) paint colors are available only on single rear wheel Fleetside/Wideside Pickup models and includes a multi-stripe decal applied over the paint break at the belt line. Color code 1 is applied to the areas above the decal (including the cab roof). Color code 2 is applied to the areas below. Outlined block "Chevrolet/GMC" decal lettering is applied to the tailgate. (A bright trim plate with lettering is applied on Fleetside/Wideside models when the Silverado/Sierra SLX Model Option is ordered.)

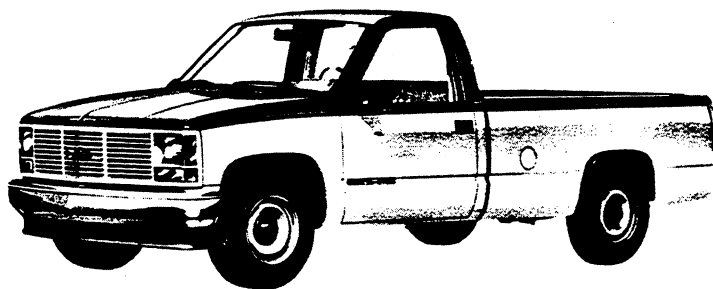

Deluxe two-tone (ZY4) paint colors are available only on single rear wheel Fleetside/Wideside Pickup models and include the belt line decal described in Special two-tone. The cab roof, hood and pickup box above the belt line decal, as well as the area below the lower styling crease line are painted Color Code 1. The areas between the decal and the lower crease line are painted Color Code 2. Outlined block "Chevrolet/GMC" decal lettering is applied to the tailgate. (A bright trim plate with lettering is applied on Fleetside/Wideside models when the Silverado/Sierra SLX Model Option is ordered.)

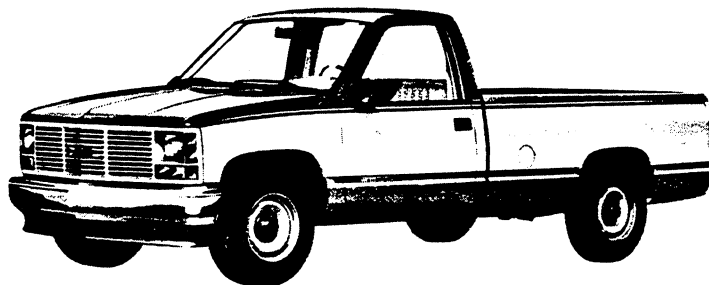

*Optional at extra cost

5.7 LITER (350 Cu. In.) EFI V8

(Ordering Code L05)

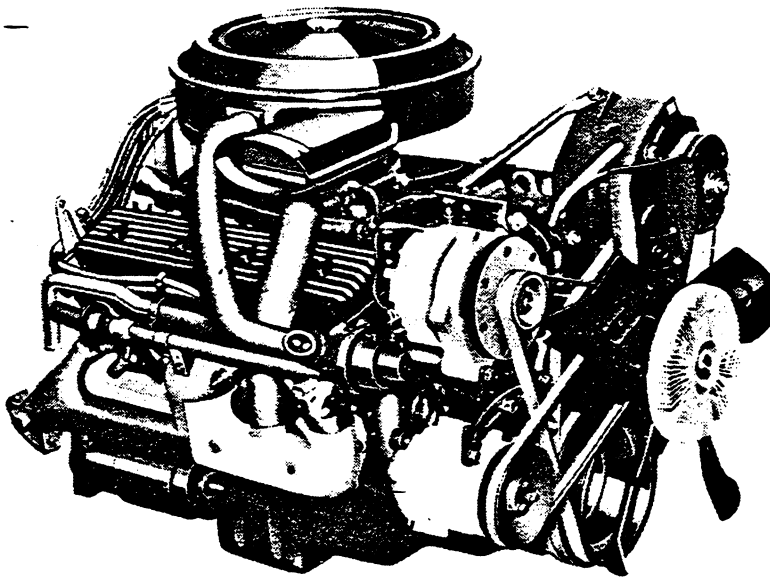

Applications

Standard: C/K3500 Pickup and Chassis-Cab; R20/2500(43) Bonus/Crew Cab Pickup; V20/2500(03) Pickup; R-V30/3500 Pickup and Chassis-Cab (All); R/V10/1500-20/2500 Suburban; V10/1500 Blazer/Jimmy; G30/3500 Sportvan/Rally.

Optional: C/K1500-2500 Pickup; G10/1500-20/2500 Sportvan/Rally; G20/2500 Chevy Van/Vandura; P20/2500-30/3500 Step-Van/Value Van/FC Chassis.

Basic Specifications

Engine type Valve-in-head
 Piston displacement (Liter/Cu. In.) 5.7/350
 Bore & stroke (nominal) 4.00" x 3.48"
 Compression ratio *9.3:1
 Carburetor type EFI
 Exhaust—Single with dual tail pipe All
 *Up to 8500 lb. GVWR; Over 8500 lb. GVWR—8.6:1.

Test Procedures

These curves represent full-throttle performance as obtained from a dynamometer test simulating actual operating conditions when the engine is in the vehicle, with ratings corrected to barometric pressure of 29.32" mercury and 77°F dry air.

Engine Ratings

R-V Models

All States

Light Duty Emissions

(8500-lb GVWR and below)

SAE net horsepower (77°F) 210 @ 4000 rpm
 SAE net torque, lb-ft (77°F) 300 @ 2800 rpm

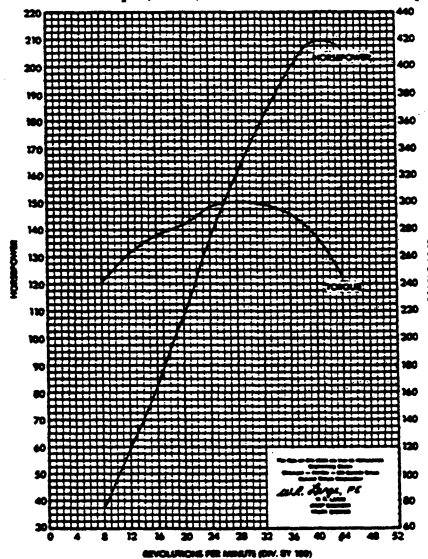

G Models

All States

Light Duty Emissions

(8500-lb GVWR and below)

SAE net horsepower (77°F) 195 @ 4000 rpm
 SAE net torque, lb-ft (77°F) 290 @ 2400 rpm

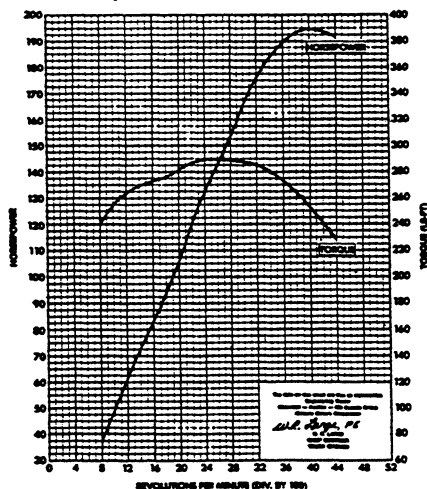

C-K-R-V-G-P Models

(except R/V20906 Suburban—49 States)

All States

Heavy Duty Emissions

(8501 to 10,000-lb GVWR)

SAE net horsepower (77°F) 185 @ 4000 rpm
 SAE net torque, lb-ft (77°F) 295 @ 2400 rpm
 Ratings for R-V 20906 Suburban (exc. California) only:
 SAE net horsepower (77°F) 195 @ 4000 rpm
 SAE net torque, lb-ft (77°F) 300 @ 2800 rpm

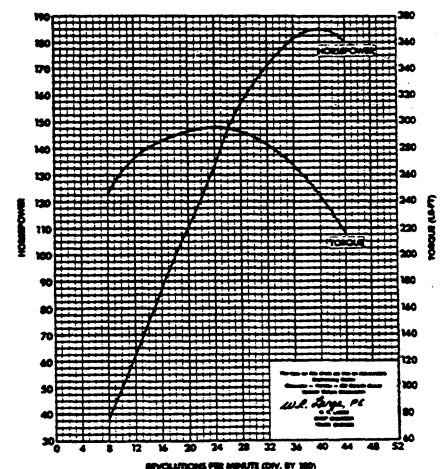

5.7 LITER (350 Cu. In.) 4-bbl V8

(Ordering Code LT9)

Applications

Standard: None
Optional: G31603-32; P30/3500;
R/V 30/3500 Chassis-Cab

Basic Specifications

Engine type Valve-in-head
Piston displacement (Liter/Cu. In.) 5.7/350
Bore & stroke (nominal) 4.00" x 3.48"
Compression ratio 8.3:1
Carburetor type 4-barrel
Exhaust—Single California
—Dual All States except California

Test Procedures

These curves represent full-throttle performance as obtained from a dynamometer test simulating actual operating conditions when the engine is in the vehicle, with ratings corrected to barometric pressure of 29.32" mercury and 77°F dry air.

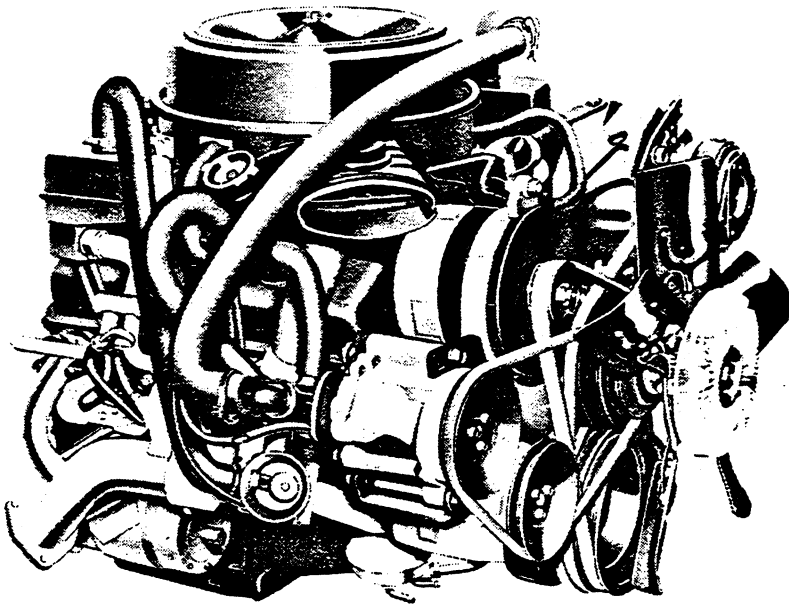

Typical Engine Shown

Engine Ratings

All States except California
Heavy Duty Emissions
(10,001 lbs GVWR and above)

SAE net horsepower (77°F) 185 @ 3600 rpm
SAE net torque, lb-ft (77°F) 285 @ 2400 rpm

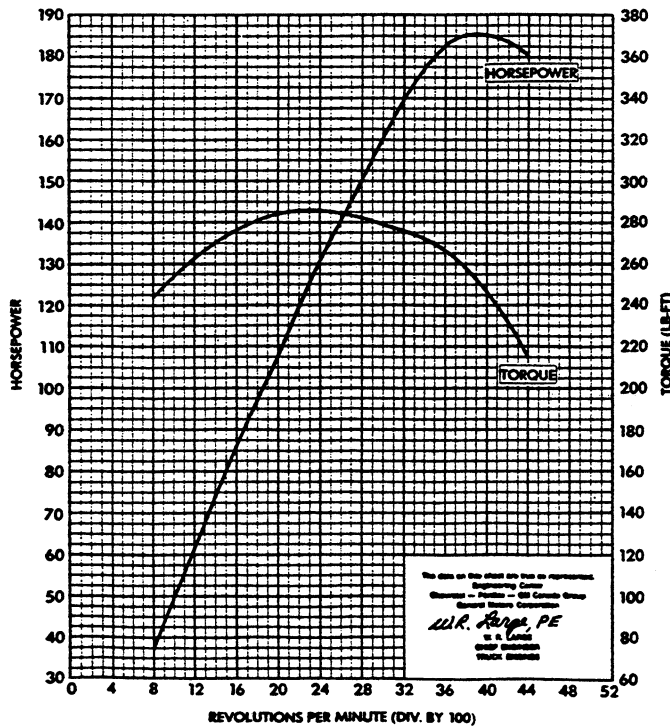

5.7 LITER (350 Cu. In.) V8 ENGINES

SPECIFICATIONS

	Series 10/1500-30/3500 (L05)		Series 30/3500 (LT9)	
	5.7 Liter/350 EFI		5.7 Liter/350 4-bbl	
Basic Description	V8; valve-in-head			
Displacement (Liter/cu in)	5.7/350		5.7/350	
Bore & Stroke	4.00 x 3.48		4.00 x 3.48	
Compression Ratio	**9.3:1		8.3:1	
Firing Order	1-8-4-3-6-5-7-2			
SAE Net Horsepower @ rpm	*210 @ 4000		185 @ 3600	
SAE Net Torque (lb-ft) @ rpm	*300 @ 2800		285 @ 2400	
Air Cleaner	Thermostatically controlled; oil wetted paper element			
Camshaft				
Bearings	Steel-backed babbitt			
Intake Valve	Opens	38° BTC		
	Closes	272° ATC		
Exhaust Valve	Opens	268° BTC		
	Closes	52° ATC		
Intake Duration	310°			
Exhaust Duration	320°			
Carburetor				
Type	TBI		4-barrel	
Make	Rochester			
Venturi ID (in)	N/A		1.218	
Throttle Bore (in)	1.69		Pri.-1.38; Sec.-2.25	
Choke Control	Computer Controlled		Automatic (Electric)	
Connecting Rods				
Material	Drop-forged Steel			
Length (in)	5.695-5.705			
Bearings	Premium aluminum			
Crankcase Ventilation	Closed positive			
Crankshaft				
Material	Cast nodular iron			
Number of Counterweights	6			
Main Journal dia (in)	2.45			
Crankpin Journal dia (in)	2.10			
Torsional Damper	Inertia; rubber mounted			
Bearings	Upper – Micro-babbitt or copper lead; Lower – premium aluminum			
Distributor	High Energy Unit, Delco-Remy Computer Controlled		Centrifugal & Vacuum Advance	
Fuel Filter				
Carburetor	Pleated fiber element			
Fuel Tank	Plastic strainer			
Lubrication System	Controlled full pressure			
Main Bearings	Direct pressure			
Camshaft Bearings	Direct pressure			
Timing Gear	Centrifugally sprayed			
Connecting Rods	Direct pressure			
Valve Mechanism	Pressure & gravity			
Cylinder Walls	Cross sprayed throw-off from rod bearing			
Piston Pins	Cross sprayed throw-off from rod bearing			
Oil Capacity (qts)				
With filter change	5			
W/o filter change	4			

*Ratings for: C/K/R/V/G/P (8501-10,000 GVWR) – SAE net horsepower 185 @ 4000 rpm
 SAE net torque (lb-ft) 295 @ 2400 rpm
 G Models (8500 GVWR & below – SAE net horsepower 195 @ 4000 rpm
 SAE net torque (lb-ft) 290 @ 2800 rpm
 R/V Suburban (Fed.) @ 8600-lb. GVWR – SAE net horsepower 195 @ 4000 rpm
 SAE net torque (lb-ft) 300 @ 2800 rpm

**Up to 8500-lb. GVWR; over 8500-lb. – 8.6:1

5.7 LITER (350 Cu. In.) V8 ENGINES

SPECIFICATIONS

	Series 10/1500-30/3500 (LO5)	Series 30/3500 (LT9)
	5.7 Liter/350 EFI	5.7 Liter/350 4-bbl
Oil Filter	Throwaway	
Capacity (qts)	.85	
Oil Pump		
Type	Spur gear; distributor shaft driven	
Capacity (gpm)	4.3 @ 2000 rpm	
Normal Pressure (psi)	45 @ 2000 rpm	
Pistons		
Material	Cast aluminum alloy	
Skirt	Closed	
Head	Sump*	
Piston Pins		
Type	Rod shrink fit to pin	
Material	Chromium steel	
Piston Rings		
Compression Rings		
Number	2	
Type	Upper – barrel; lower – inside bevel	
Material	Cast iron alloy	
Oil Control Ring		
Number	1	
Type	Multi-piece	
Material	Steel	
Thermostat	Harrison; 195°	
Valve Train		
Type	Individually mounted rocker arms, push rod actuated	
Lifters	Hydraulic	
Rocker Arm Ratio	1.50:1	
Valve Guides	Integral with cylinder head	
Valve Lash	Zero	
Intake Valves		
Material	Alloy steel	
Diameter (in.)	1.94	1.72
Face Coatings	None on LO5; aluminized on LT9	
Seats	Machined in cylinder head	
Exhaust Valves		
Material	High alloy steel	
Diameter (in.)	1.50	
Face Coating	Aluminized	
Seats	#Machined in cyl. head; induction hardened	Hardened inserts
Rotators (exhaust)	Yes	
Water Pump		
Type	Centrifugal	
Capacity (gpm)	21.6 @ 2000 rpm	

*Chamfered top land on light duty emissions

#Models with GVWR of 8501-10,000 have hardened inserts.

ENGINE & COOLING

6.2 DIESEL ENGINE FEATURES

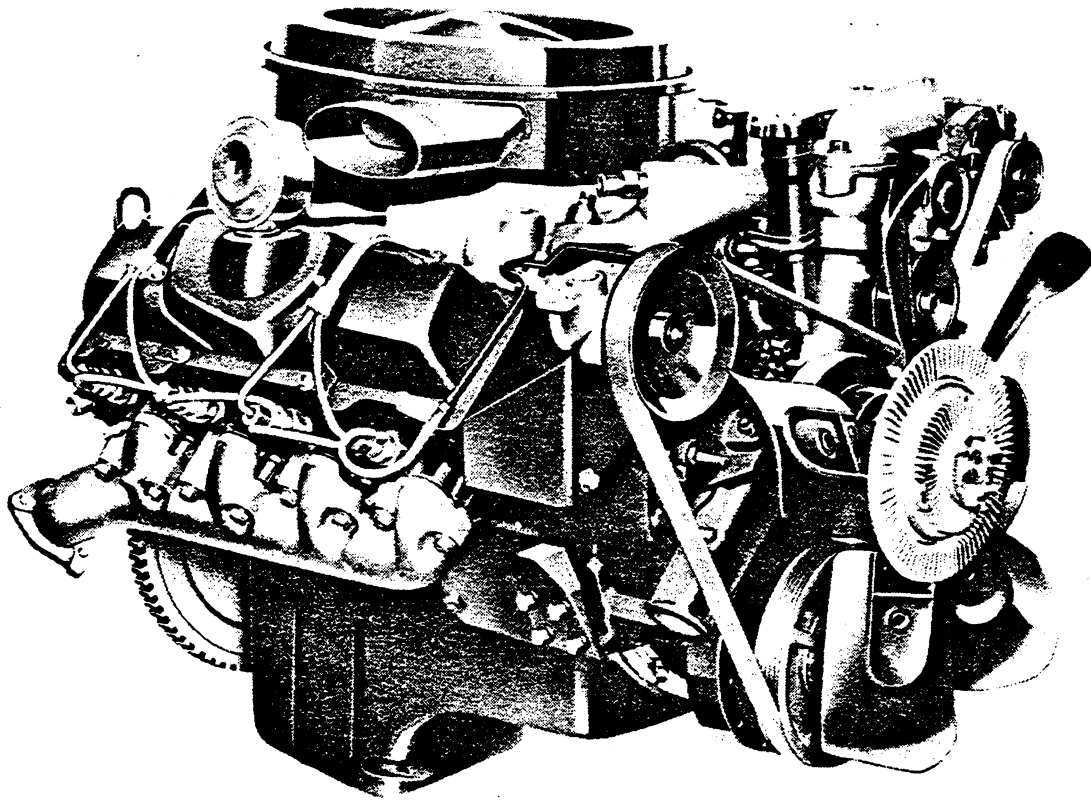

A 90° 4-cycle V8 diesel engine standard on full-size Pickups, Suburbans, Chassis-Cab, Blazer/Jimmy, Chevy Van/Vandura, Sportvan/Rally, Cutaway Van, Hi-Cube Van, FC/Step-Van/Value-Van and Motor Home Chassis Diesel models. It's no secret that more and more truck owners are going diesel—a practical alternative to gas engines. This totally new powerplant is a satisfying combination of power and common sense—6.2 liters of tough-towing, big-hauling, hardworking, fuel-sipping power.

The right power and the right mileage—right now! This made-in-America V8 engine, designed and manufactured specifically for trucks, has the traditional fuel-economy advantages of diesel over gasoline. And extensive testing also indicates that the 6.2 Liter Diesel can handle heavy loads and stop-and-go traffic. It also offers some of the best mileage estimates ever in full-size GM light-duty trucks. Simply put, this new V8 presents a powerful case why you should go diesel.

Trailer towing muscle. Torque, or low-end power, is an important feature on any truck. But the 6.2 Liter Diesel really delivers here. It's rated at 240/259 (LD/HD) lb.-ft. at 2000 RPM—that means it'll dig in and pull

hard fully loaded. It also means it'll tow a heap of trailer. When properly equipped, a full-size Diesel Pickup or Suburban can move as much as 13,500 lbs., which includes itself, trailer, passengers, cargo and equipment.

Rugged diesel construction throughout. The 6.2 Liter Diesel is built to take a lot. It features thick cylinder walls, a forged steel camshaft, a nodular iron crankshaft (nodular iron is gray cast-iron with a magnesium alloy), five head bolts around each cylinder, and four-bolt main bearing caps which help provide rigid support for the crankshaft and reduce stresses.

Why you should go diesel. It's simple. If you plan to put a lot of miles on your truck and/or high idle operations and if you're at all concerned about fuel prices, you should consider going diesel. In addition, diesel offers you high torque power for hauling. And diesels have a well-earned reputation in applications ranging from locomotives to ocean tankers. And here's the clincher: low maintenance costs. There are no spark plugs, distributor or ignition wiring. So you don't have these to maintain. Just about any way you look at it, diesels can be a big plus for most truck applications.

ENGINE & COOLING

6.2 DIESEL ENGINE FEATURES

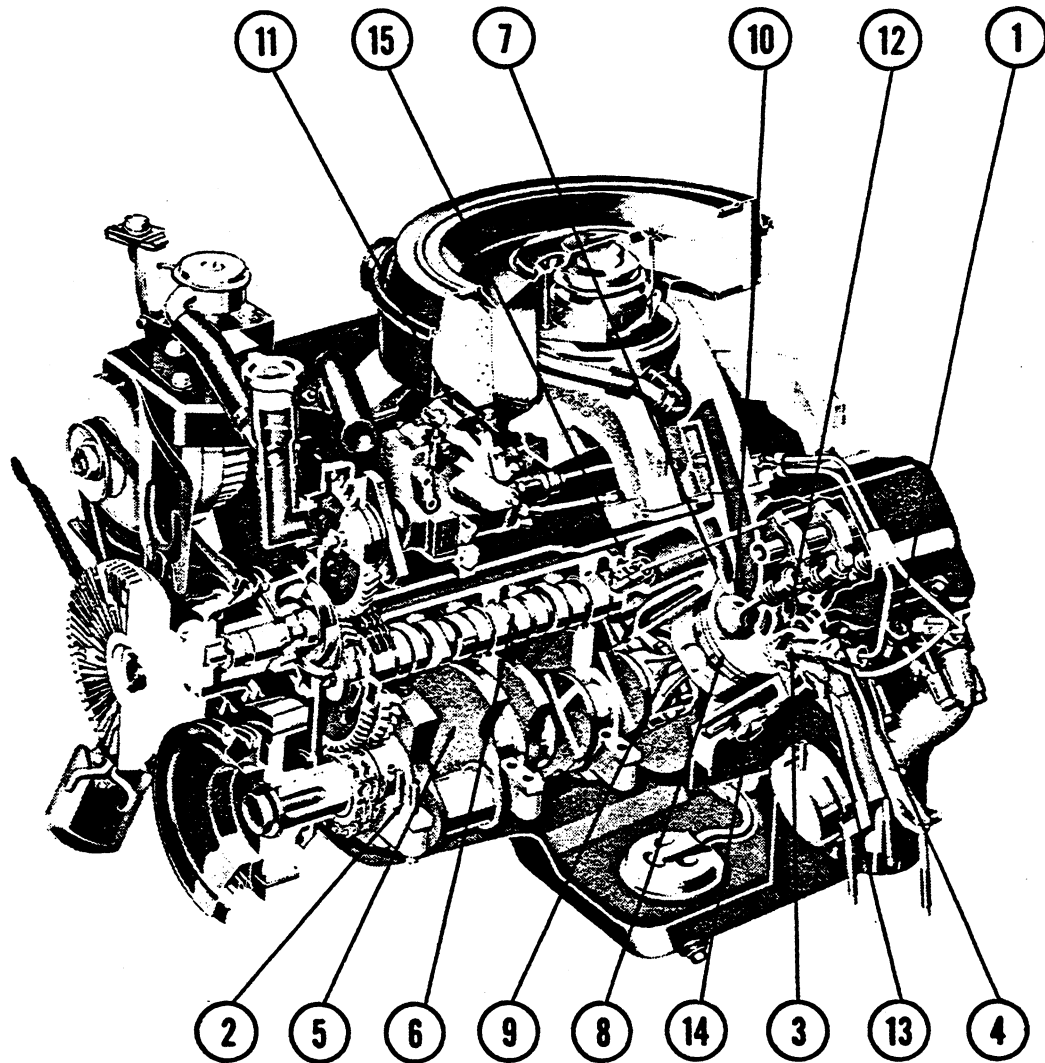

1. Seventeen-bolt head design for a tight gasket seal all around. Locates five bolts around each cylinder bore.
2. Four-bolt main bearing caps provide rigid support for the crankshaft.
3. Ricardo Comet V precombustion chambers for high efficiency and low noise levels.
4. Pintle-type fuel injector nozzles with fuel lines made of high-pressure steel tubing.
5. Nodular iron crankshaft with external torsional damper.
6. Forged steel carburized camshaft for strength and durability.
7. Cast alloyed gray iron cylinder block for overall strength. Cylinder walls are reborable.
8. Cast aluminum pistons combine strength and light weight.
9. Forged heat-treated steel connecting rods for

- strength and rigidity.
10. Silchrome® steel intake valves with full-chrome stems for durability.
11. Stanadyne® mechanical distributor fuel system includes full mechanical governor with friction damper ring. Corrosion-resistant springs and check springs.
12. Stellite-faced exhaust valves with full-chrome stems and positive valve rotators.
13. Glow plug starting system preheats the pre-combustion chambers for fast cold-engine starts.
14. Engine block heater for fast starts in cold weather.
15. Roller hydraulic lifters help provide precise operation of valve train components.
16. Complete integral fuel filter system includes a two-stage fuel filter, a fuel/water separator, water-in-fuel dash warning light, an electric fuel heater and a filter change signal.

ENGINE & COOLING

6.2 DIESEL ENGINE FEATURES

Here's why diesel engines work so efficiently.

There are three major reasons why diesel engines are generally more economical than comparably sized gasoline engines: air/fuel ratio, compression ratio, and price of fuel.

Diesels have significantly higher air/fuel ratios than comparable gasoline engines—which means that diesels burn proportionately less fuel.

A diesel's air/fuel ratio is about 80-to-1 at idle and 20-to-1 at full load. Compare this to gas engines, which use about a 14-to-1 mixture of air and fuel at idle, and a 12-to-1 mixture at full load.

Diesel engines depend on compression for ignition of fuel, whereas the gas engine depends on spark plugs. The diesel, with its higher compression ratio, more efficiently converts fuel-heat energy into mechanical energy. That energy provides the diesel with its traditionally high torque power for hauling.

Thanks to functional differences like these, you can get more miles per gallon with a diesel engine than with a comparably sized gasoline engine. What's more, you do it with traditionally lower-priced fuel. Another diesel plus: no conventional gas engine tune-ups—or spark plugs, distributor or ignition wiring to maintain.

The 6.2 Liter Diesel. Built in one of the world's newest engine plants. GM's Moraine engine assembly plant in Ohio is an impressive sight. It is a totally redesigned plant with the latest modern technology working to produce a rugged, high-efficiency power-plant.

Quality is the byword here. You can see it in the extensive quality checks, and in the intensive testing procedures regularly performed during and after assembly. For instance, all parts are air-pressure leak tested to check for quality fits; TV monitors are used to check whether all valve lifters are in place. And each new diesel is thoroughly computer-checked after assembly. Some engines are randomly tested in a laboratory: they're run at various throttle positions for

numerous checks and testing.

A sophisticated computer network. This diesel plant uses more programmable controllers than any other manufacturing plant in the U.S.—400. These terminals help run the machines and make automatic tool compensations. Another important feature is the central "host" computer which efficiently oversees and monitors the subordinate controllers.

The emphasis is on quality. An engine is only as good as the people who build it. That's why all employees are required to take 80 rigorous hours of classroom training—hands-on experience with the engine—to give them the total picture. But it doesn't stop there. Each employe is responsible for the quality of his work. The object at all times is to build it right the first time.

Special 6.2 Liter Diesel Highlights. □ This diesel engine is designed specifically for truck use. □ The 6.2 Liter Diesel uses nodular iron on its bearing caps—a significantly stronger design than those without nodular iron. □ The camshaft is made of forged steel and is carburized to give it strength. □ The fuel pump is a Roosa Master™—a brand used worldwide on many diesels, including tractors. □ A highly proven Ricardo Comet precombustion chamber with its swirl-type design provides efficient fuel burn and impressive emissions control characteristics. □ The 6.2 Liter Diesel is equipped with a standard oil cooler. □ A block heater and glow plugs are standard to aid cold-weather starts. At 0°F. the glow plugs can preheat the prechambers in about 6 seconds. □ There is extensive moisture-in-fuel protection, including (1) an integral two-stage fuel filter, a fuel/water separator with instrument panel warning light (2) an electric fuel heater, and (3) a fuel filter change signal. □ The higher compression ratios of diesels demand quality dimensions in design and production. The 6.2 Liter Diesel is a very close-tolerance engine. Most of the critical dimensions are controlled to within two-thousandths of an inch. That's about half the thickness of this piece of paper!

ENGINE & COOLING

6.2 DIESEL ENGINE FEATURES

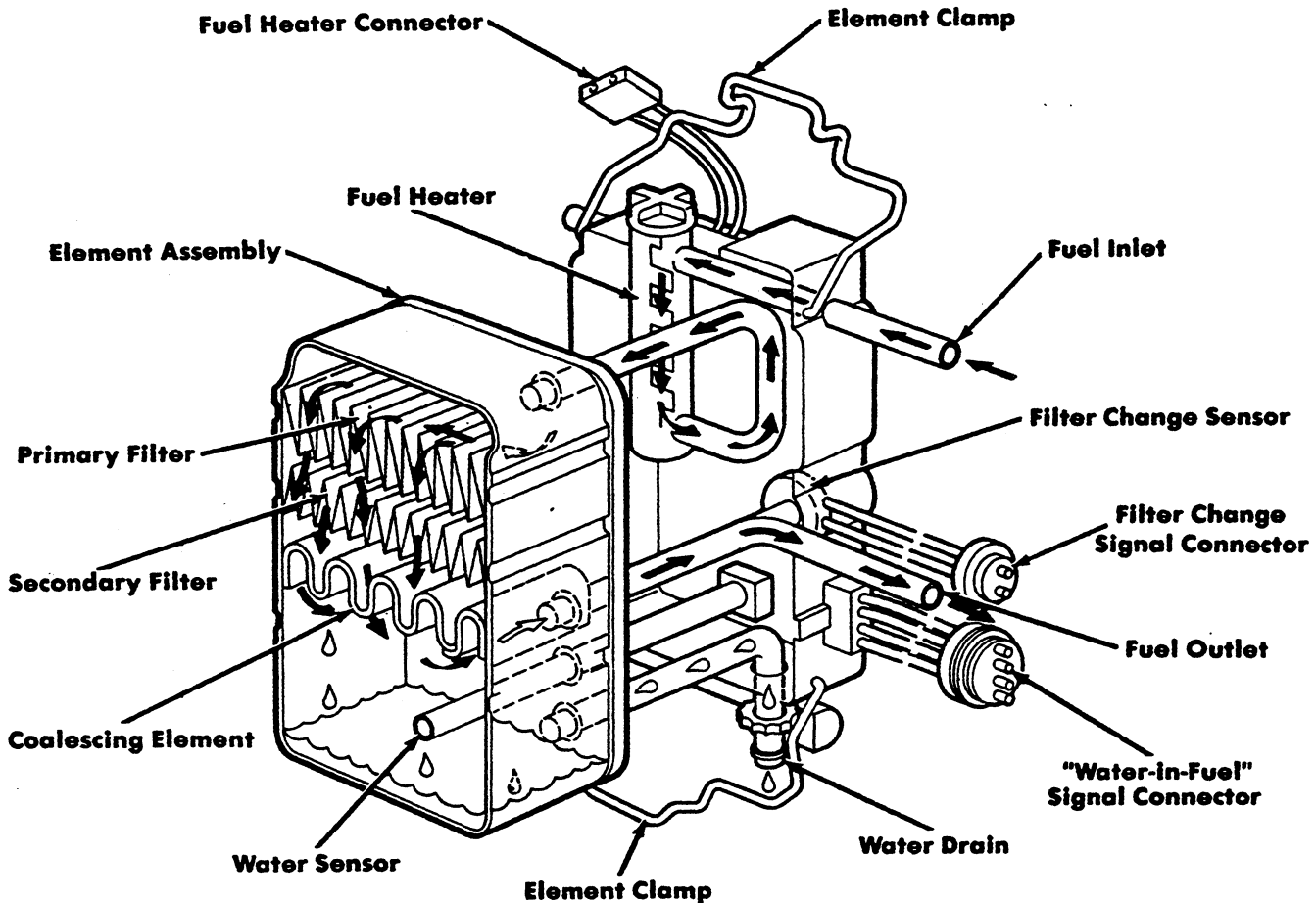

Single Unit Water/Fuel Separator, Two-Stage Fuel Filter, Fuel Heater. Mounted either to the engine or the engine compartment fire wall, depending on model, this compact modular unit consists of two main components—a permanently mounted aluminum base with integral element holding clamps and a rectangular metal element. The metal element contains two stages of fuel filter media and a third stage of coalescing material to effect water separation. The lower section of the element contains a water collection area with a capacity of approximately 260cc. The water sensor signal level is set at 50cc. to provide an early alert of water ingress.

Fuel enters at top right hand inlet (see flow schematic above) and flows into heating chamber. Heater is activated at 8°C. (46°F) and below. Heated fuel enters element at top and flows down through the two stage fuel filter media pack. While passing through the third stage, water coalesces out and drops to a sump holding area. Clean fuel returns to the base and exits to the fuel injection pump. An electrical signal is obtained from the filter change sensor located in the return path. A water drain petcock on the base allows collected water to be drained from the unit when necessary. An air

vent valve is located on top of the filter base to purge air out when a new filter assembly is installed.

Engine Oil

- Engine oil requirement is grade SF/CD or SF/CC.
- Oil change interval for normal service is every 5000 miles
- In severe service, a 2500-mile oil change interval is recommended
- *Always* replace oil filter element each time engine oil is changed

Starting Procedure (when engine is warm)

- Same as gasoline engine.

Starting Procedure (when engine is cold)

- Turn the ignition switch to the "on" position
- "Glow Plugs" light comes on
- Wait for glow plugs to heat the combustion chambers
- When the "Glow Plugs" light goes off, turn ignition key to start engine.

Cold Weather Starting

- When outside temperatures drop below 0°F (-18°C), use the engine block heater.

Starting Aids

- In cold weather, do *not* under any circumstance use ether or other chemical starting assists.

6.2 LITER (379 Cu. In.) V8 DIESEL

(Ordering Code LH6)

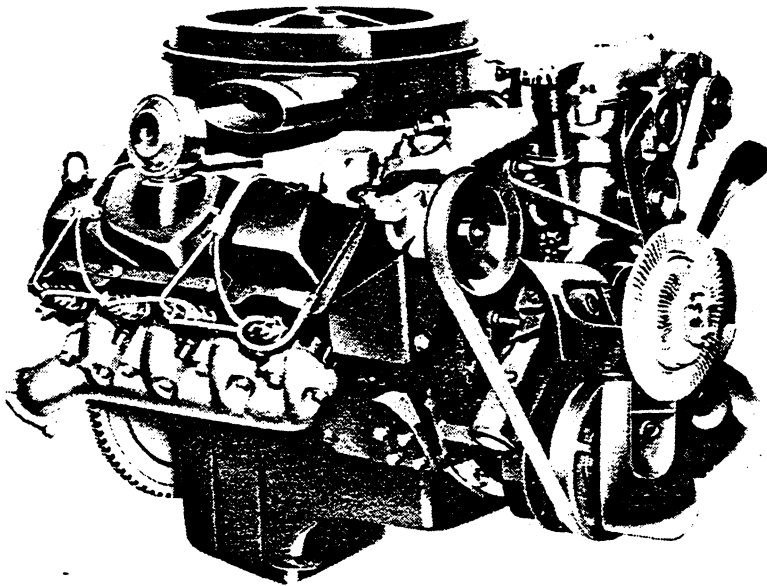

Applications

Standard: C-K 1500-2500; R-V 10/1500 Suburban;
V 10/1500 Blazer/Jimmy; G20/2500 Diesel
Models

Optional: None

Basic Specifications

Engine type Valve-in-head
Piston displacement (Liter/Cu. In.) 6.2/379
Bore & stroke (nominal) 3.98" x 3.82"
Compression ratio 21.3:1
Exhaust Dual

Test Procedures

These curves represent full-throttle performance as obtained from a dynamometer test simulating actual operating conditions when the engine is in the vehicle, with ratings corrected to barometric pressure of 29.32" mercury and 77°F dry air.

Engine Ratings

R/V/G Models

All States

SAE net horsepower (77°F) 130 @ 3600 rpm
SAE net torque, lb-ft (77°F) 240 @ 2000 rpm

C/K Models

All States

SAE net horsepower (77°F) †126 @ 3600 rpm
SAE net torque, lb-ft (77°F) †240 @ 2000 rpm
†Ratings shown are for manual transmission;
for automatic transmission, ratings are:
H.P. — 140 @ 3600 rpm
Torque — 247 @ 2000 rpm

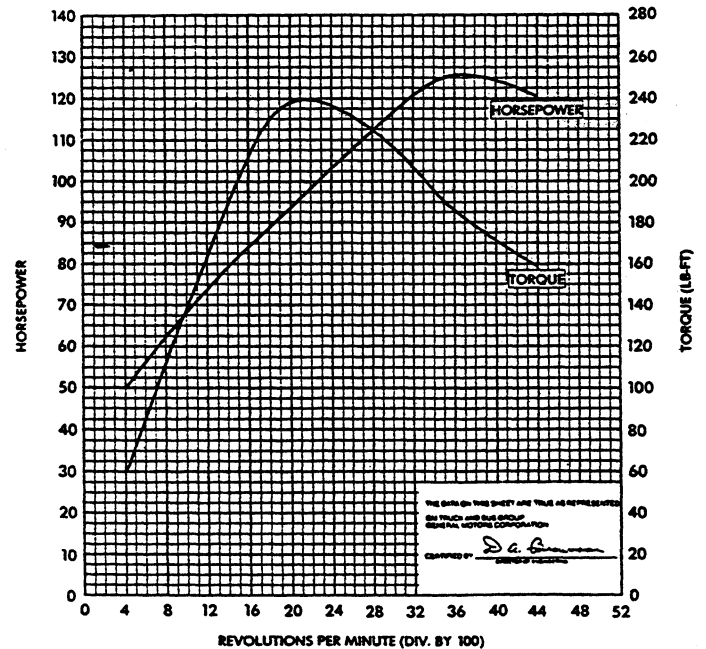
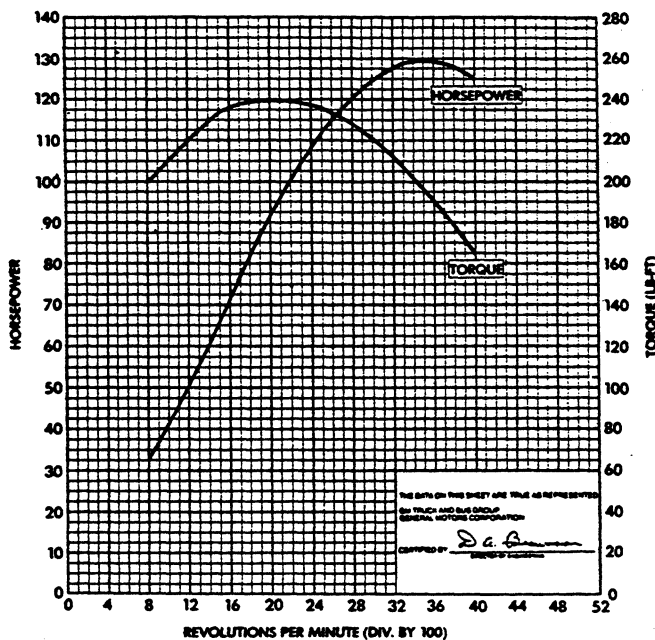

6.2 LITER (379 Cu. In.) V8 DIESEL

(Ordering Code LL4)

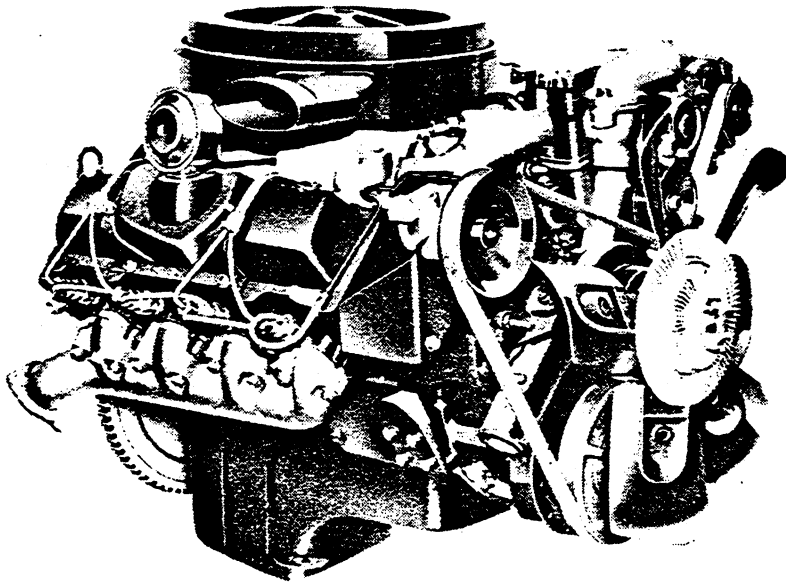

Applications

Standard: 20/2500 Bonus/Crew Cab Pickup;
 R-V20/2500 Suburban; P20/2500;
 C-K-R-V-G-R30/3500 (except P31832)
 Diesel Models
 Optional: None

Basic Specifications

Engine type Valve-in-head
 Piston displacement (Liter/Cu. In.) 6.2/379
 Bore & stroke (nominal) 3.98" x 3.82"
 Compression ratio 21.3:1
 Exhaust Dual

Test Procedures

These curves represent full-throttle performance as obtained from a dynamometer test simulating actual operating conditions when the engine is in the vehicle, with ratings corrected to barometric pressure of 29.32" mercury and 77°F dry air.

Engine Ratings

R/V/G/P Models

All States

SAE net horsepower (77°F) 148 @ 3600 rpm
 SAE net torque, lb-ft (77°F) 259 @ 2000 rpm

C/K Models

All States

SAE net horsepower (77°F) 143 @ 3600 rpm
 SAE net torque, lb-ft (77°F) 257 @ 2000 rpm

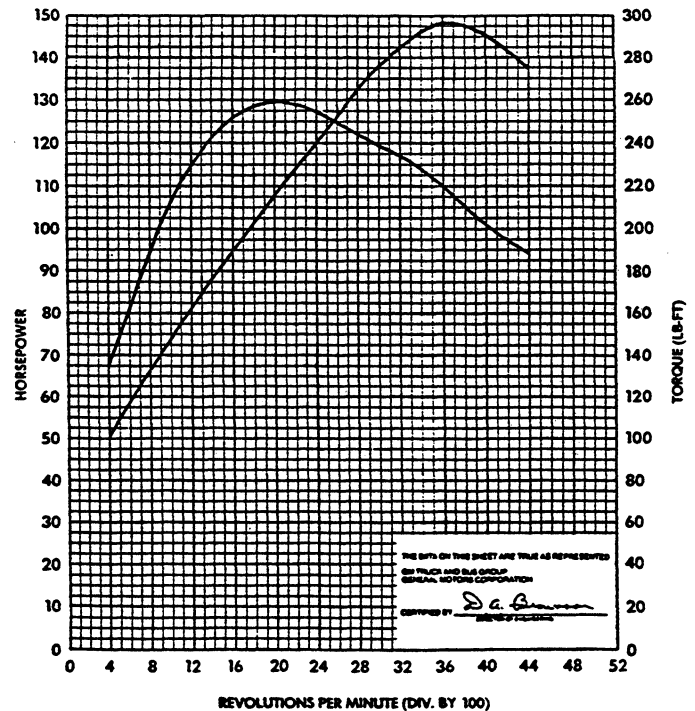
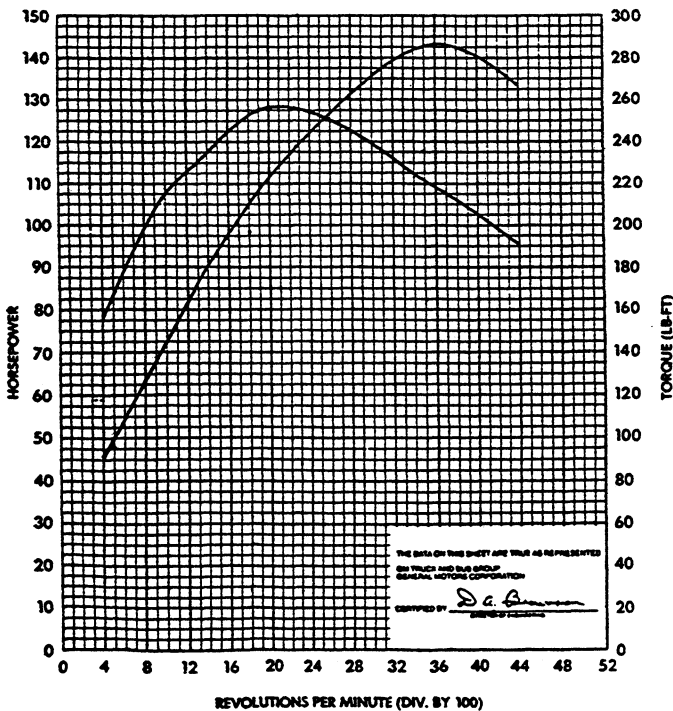

6.2 LITER (379 Cu. In.) V8 DIESEL

SPECIFICATIONS

		6.2 Liter/379 V8
Basic Description		Fuel Injection
Displacement (Liter/Cu. In.)		V8; valve-in-head
Bore & Stroke (in)		6.2/379
Compression Ratio		3.98 x 3.82
Firing Order		21.3:1
SAE Net Horsepower @ rpm		1-8-7-2-6-5-4-3
SAE Net Torque (lb-ft) @ rpm		†130 @ 3600
Air Cleaner		†240 @ 2000
Camshaft		Oil wetted paper element
Bearings		Steel-backed Aluminum
Intake Valve (at .004" cam lift)	Opens	13° BTC
	Closes	224° ATC
Exhaust Valve (at .004" cam lift)	Opens	248° BTC
	Closes	25° ATC
Intake Duration		237°
Exhaust Duration		273°
Fuel System		
Lift Pump-Type		Mechanical diaphragm – camshaft drive
High Pressure Pump-Type		Stanadyne – camshaft drive
Fuel Shut-off		Electric solenoid
Injector-Type		Pintle (Bosch)
Size and Spray Pattern		.017-30°
Actuation		Automatic
Injection Pressure		1800 psi
Connecting Rods		
Material		Drop forged steel
Length (in)		6.2783-6.2803
Bearings		Premium aluminum
Crankcase Ventilation		Closed positive
Crankshaft		
Material		Cast nodular iron
Number of Counterweights		6
Main Journals (in)		2.95
Crankpin Journals (in)		2.40
Torsional Damper		Inertia; rubber mounted
Bearings		Premium aluminum
Fuel Filter		
Injector		Pleated fiber element (Primary and Secondary)
Fuel Tank		Mesh strainer
Lubrication System		Controlled full pressure
Main Bearings		Direct pressure
Camshaft Bearings		Direct pressure
Timing Gear		Spray
Connecting Rods		Direct pressure
Valve Mechanism		Pressure & gravity
Cylinder Walls		Spray
Piston Pins		Spray

†R/V/G LD Emission ratings shown.

C/K LD Emission ratings are:

With manual transmission – H.P. 126 @ 3600
Torque 240 @ 2000
With automatic transmission – H.P. 140 @ 3600
Torque 247 @ 2000

HD Emission ratings are:

C/K models – H.P. 143 @ 3600
Torque 257 @ 2000
R/V/G/P models – H.P. 148 @ 3600
Torque 259 @ 2000

TER (379 Cu. In.) V8 DIESEL

SPECIFICATIONS

6.2 Liter/379 V8
Fuel Injection
7
Full flow; throwaway type
0.85
Spur gear; shaft driven
5 @ 2000 rpm
35 psi minimum @ 1500-3000 rpm
Cast aluminum alloy with top ring insert
Slipper type
Flat with cast swirl sump
Floating pin
Chromium steel
2
Upper - Keystone type with barrel molybdenum face; lower - tapered face
Cast alloy iron
1
Multi-piece
Steel
Robertshaw; 190°
Shaft mounted rocker arms, push rod actuated
Hydraulic with roller follower
1.50:1
Cast alloy iron; integral with head
Zero
Alloy steel
1.97
None
Machined in cylinder head; induction hardened
Alloy steel
1.65
Stellite
Machined in cylinder head; induction hardened
Exhaust
Centrifugal
35 @ 2000 rpm

7.4 LITER (454 Cu. In.) 4-bbl V8

(Ordering Code LE8)

Applications

Standard: R-V30/3500 Chassis-Cabs; P30/3500 Motor Home Chassis
 Optional: P30/3500 Step-Van/Value Van/FC Chassis

Basic Specifications

Engine type Valve-in-head
 Piston displacement (Liter/Cu. In.) 7.4/454
 Bore & stroke (nominal) 4.25" x 4.00"
 Compression ratio 7.9:1
 Carburetor type 4-barrel
 Exhaust—Dual All

Test Procedures

These curves represent full-throttle performance as obtained from a dynamometer test simulating actual operating conditions when the engine is in the vehicle, with ratings corrected to barometric pressure of 29.32" mercury and 77°F dry air.

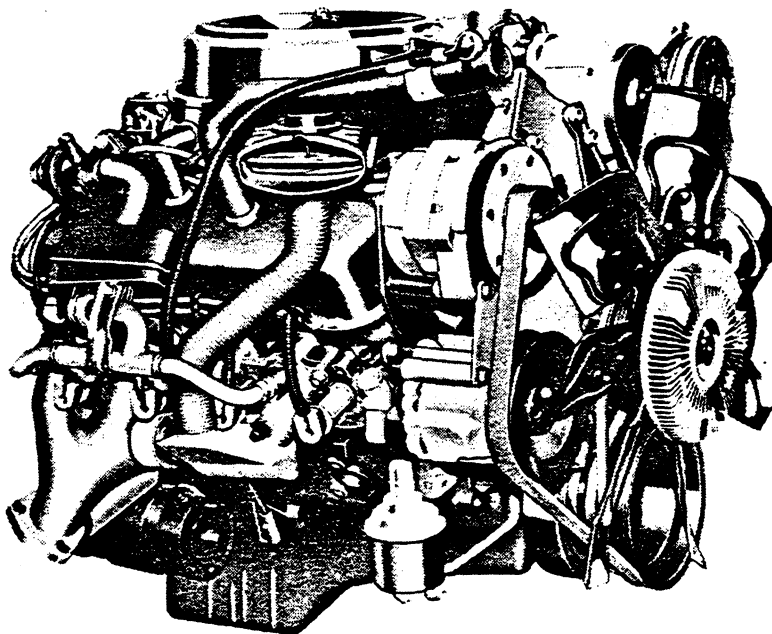

Engine Ratings

All States
 Heavy Duty Emissions
 (10,001 lbs GVWR and above)

SAE net horsepower (77°F) 230 @ 3800 rpm
 SAE net torque, lb-ft (77°F) 370 @ 2800 rpm

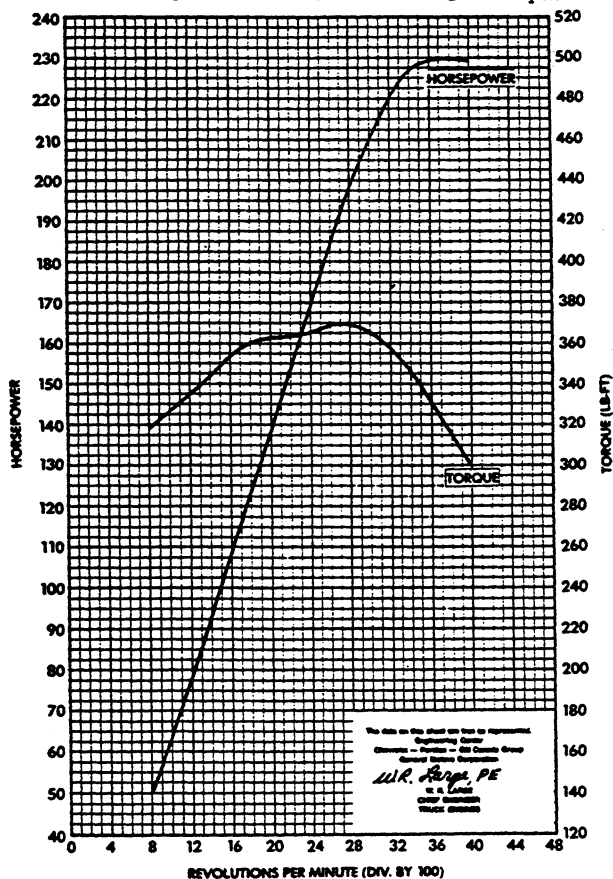

7.4 LITER (454 Cu. In.) EFI V8

(Ordering Code L19)

Applications

Standard: None
 Optional: R20/2500 Pickups and Suburbans; C/K3500
 Pickups and Chassis-Cabs; R-V30/3500 Pickups and
 Chassis-Cabs

Basic Specifications

Engine type Valve-in-head
 Piston displacement (Liter/Cu. In.) 7.4/454
 Bore & stroke (nominal) 4.25" x 4.00"
 Compression ratio 79:1
 Carburetor type EFI
 Exhaust—Dual All

Test Procedures

These curves represent full-throttle performance as
 obtained from a dynamometer test simulating actual
 operating conditions when the engine is in the ve-
 hicle, with ratings corrected to barometric pressure
 of 29.32" mercury and 77°F dry air.

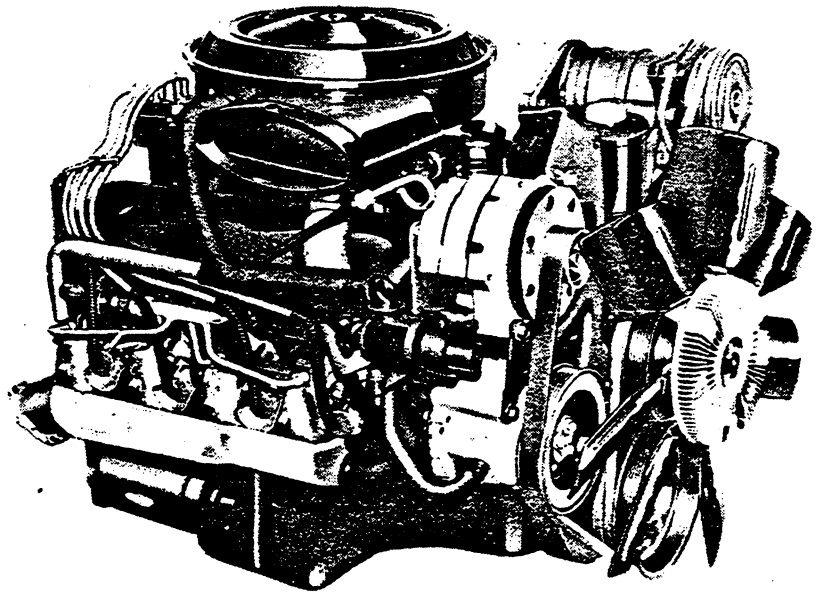

Typical Engine Shown

Engine Ratings

All States
 Heavy Duty Emissions
 (8500 to 10,000 lb. GVWR)

SAE net horsepower (77°F) 230 @ 3600 rpm
 SAE net torque, lb-ft (77°F) 385 @ 1600 rpm

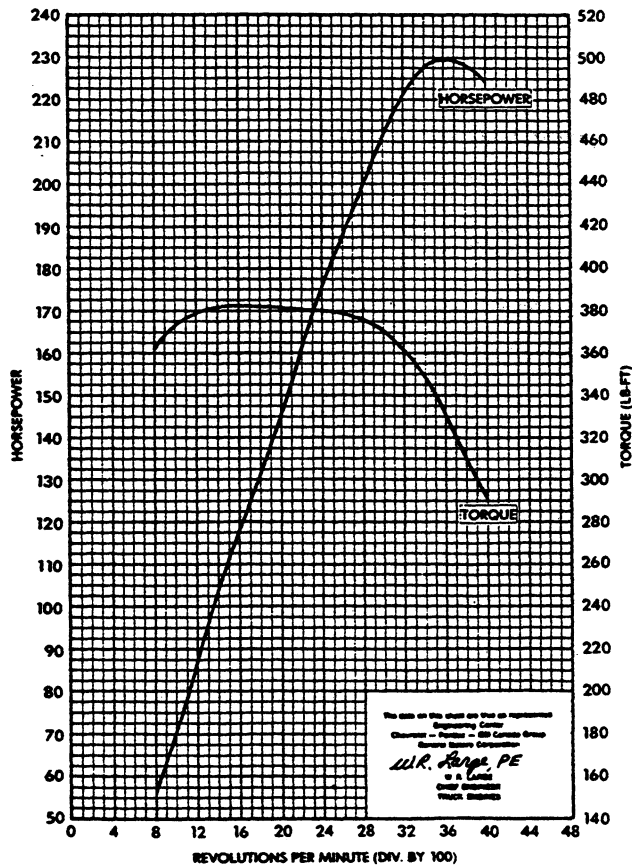

7.4 LITER (454 Cu. In.) V8 ENGINES

SPECIFICATIONS

	HIGH TORQUE	
	7.4 Liter/454 EFI	7.4 Liter/454 4-bbl
Basic Description	V8; valve-in-head	
Displacement (Liter/cu in)	7.4/454	
Bore & Stroke (in)	4.251 x 4.00	
Compression Ratio	7.9:1	
Firing Order	1-8-4-3-6-5-7-2	
SAE Net Horsepower @ rpm	230 @ 3600	†230 @ 3800
SAE Net Torque (lb-ft) @ rpm	385 @ 1600	†370 @ 2800
Air Cleaner	Thermostatically controlled; oil wetted paper element	
Camshaft		
Bearings	Steel-backed babbitt	
Intake Valve (at .004" cam lift)	Opens	18° BTC
	Closes	246° ATC
Exhaust Valve (at .004" cam lift)	Opens	245° BTC
	Closes	33° ATC
Intake Duration	264°	
Exhaust Duration	278°	
Carburetor		
Type	TBI	4-Barrel
Make	Rochester	Rochester Mod-Quad
Venturi ID (in)	N/A	1.218
Throttle Bore (in)	N/A	1.38 Primary; 2.25 Secondary
Choke Control	Computer Controlled	Automatic
Connecting Rods		
Material	Drop forged steel	
Length (in)	6.130-6.140	
Bearings	Premium aluminum	
Crankcase Ventilation	Closed positive	
Crankshaft		
Material	Cast nodular iron	
Number of Counterweights	6	
Main Journal (in)	2.75 (Nominal)	
Crankpin Journal (in)	2.199-2.20	
Torsional Damper	Inertia; rubber mounted	
Bearings	Steel with Premium aluminum or copper-lead insert	
Distributor	HEI Computer Controlled High Energy Unit, Delco-Remy	HEI with Centrifugal & Vacuum Advance
Fuel Filter		
Carburetor	Pleated fiber element	
Fuel Tank	Mesh strainer	
Lubrication System	Controlled full pressure	
Main Bearings	Direct pressure	
Camshaft Bearings	Direct pressure	
Timing Gear	Centrifugally sprayed	
Connecting Rods	Direct pressure	
Valve Mechanism	Pressure & gravity	
Cylinder Walls	Cross sprayed by pressurized jets	
Piston Pins	Splash	

†The following ratings apply to California only: SAE net horsepower 230 @ 3800 rpm
SAE net torque (lb-ft) 360 @ 2800 rpm

7.4 LITER (454 Cu. In.) V8 ENGINES SPECIFICATIONS

	HIGH TORQUE	
	7.4 Liter/454 EFI	7.4 Liter/454 bbl.
Oil Capacity		
With filter change	7	
W/O filter change	6	
Oil Filter		
Standard	Full-flow; replaceable element	
Capacity (qts)	.85	
Oil Pump		
Type	Spur gear; distributor shaft driven	
Capacity (gpm)	6.0 @ 2000	
Normal Pressure (psi)	40 @ 2000 rpm	
Pistons		
Material	Cast aluminum alloy	
Skirt	Slipper	
Head	Sump	
Piston Pins		
Type	Rod shrink fit to pin	
Material	Chromium steel	
Piston Rings		
Compression Rings		
Number	2	
Type	Upper – barrel face; lower – taper face	
Material	Cast alloy iron	
Oil Control Rings		
Number	1	
Type	Multi-piece	
Material	Steel	
Thermostat	Harrison; 195°	
Valve Train		
Type	Individually mounted rocker arms, push rod actuated	
Lifters	Hydraulic	
Rocker Arm Ratio	1.70:1	
Valve Guides	Pressed-in; cast alloy iron	
Valve Lash	Zero	
Intake Valves		
Material	Alloy steel	
Head Diameter (in)	2.060-2.070	
Face Coating	Aluminized	
Seats	Machined in cylinder head	
Rotators (intake)	Yes	
Exhaust Valves		
Material	High alloy steel	
Head Diameter (in)	1.715-1.725	
Face Coating	Aluminized and stellite faced	
Seats	Hardened Inserts	
Rotators (exhaust)	Yes	
Water Pump		
Type	Centrifugal	
Capacity (gpm)	24.5 @ 2000 rpm	

COOLING SYSTEMS

STANDARD COOLING SYSTEMS

§TUBE AND CENTER CROSS-FLOW-TYPE RADIATOR WITH
MULTILOUVER DESIGN AND 15 LB. PRESSURE CAP.

SERIES	Engine (Liter/Cu. In.)	Radiator			System Capacity (gal) ★	Fan (No. blades x diameter x pitch)
		Thick- ness (in)	Dist. Between Tubes (Constant) (in)	Frontal Area (sq in)		
Astro/Safari	2.5/151	.93	.18	358	2.3	4 x 15.98 x 1.26
	4.3/262	.93	.18	407	3.4	3 x 18.03 x 2.51 ■
S-10/15	2.5/151	.98	.24	292	3.0	4 x 14.49 x 1.26
	2.8/173	.98	.18	350	2.9	5 x 15.0 x 2.05 ■
	4.3/262	.93	.14	395	3.4	3 x 18 x 2.0 ■
C/K 1500, C/K 2500	4.3/262	.93	.12	358	3.6	3 x 19 x 2.0 ■
	5.0/305	.93	.12	358	3.8	3 x 19 x 2.0 ■
	5.7/350	1.34	.16	358	3.9	3 x 19 x 2.0 ■
	6.2/379	1.58	.12	576	6.2	5 x 20 x 2.56 ■
R/V10/1500	5.7/350	.98	.16	537	4.3	3 x 19 x 2.71 ■
	6.2/379	1.57	.16♦	645	6.2	5 x 20 x 2.87 ■
R/V20/2500	4.8/292	.98	.16	445	3.8	3 x 19 x 2.71 ■
	5.7/350	.98	.16†	479	4.3	3 x 19 x 2.71 ■
	7.4/454	1.57	.16	537	5.4	5 x 19.5 x 2.18 ■
	6.2/379	1.57	▲	645	6.2	5 x 20 x 2.87 ■
G10/1500, G20/2500	4.3/262	.93	.14	358	3.4	3 x 19 x 2.0 ■
	5.0/305	.98	.16	479	4.2	3 x 19 x 2.0 ■
	5.7/350	.98	.12#	479	4.2	3 x 19 x 2.0 ■
	6.2/379	1.57	.12	479	6.3	5 x 20 x 2.87 ■
C/K 3500	5.7/350	1.34	.16	358	3.9	3 x 19 x 2.0 ■
	7.4/454	2.17	.10	576	6.3	5 x 20 x 2.56 ■
	6.2/379	1.58	.12	576	6.2	5 x 20 x 2.56 ■
P20/2500	4.8/292	.98	.16	447	3.5	5 x 19 x 2.5 ■
	5.7/350	.98	.16	481	4.0	5 x 19.5 x 2.18 ■
	6.2/379	1.57	.12	646	6.2	5 x 19.5 x 2.88 ■
R30/3500	4.8/292	.98	.16	445	3.8	3 x 19 x 2.71 ■
	5.7/350	.98	.16†	479	4.3	3 x 19 x 2.71 ■
	7.4/454	1.57	.16	537	5.4	5 x 19.5 x 2.18 ■
	6.2/379	1.57	.12	645	6.2	5 x 20 x 2.87 ■
G30/3500 (05) w/o C6P	4.3/262	.93	.14	358	3.4	3 x 19 x 2.0 ■
G30/3500 (06) w/o C6P	5.7/350	.98	.12	479	4.2	5 x 19.5 x 2.0 ■
G30/3500/C6P (05), G30/3500/C6P (06)	5.7/350	.98	.12	479	4.2	5 x 19.5 x 2.0 ■
	7.4/454	1.34	.10	488	5.8	5 x 20 x 2.61 ■
	6.2/379	1.57	.12	479	6.2	5 x 20 x 2.87 ■
G30/3500 (03)	5.7/350†	1.57	.12	479	4.3	5 x 19.5 x 2.0 ■
	6.2/379†	1.57	.12	479	6.2	5 x 20 x 2.87 ■
G30/3500 (32)	5.7/350†	1.57	.12	479	4.3	5 x 19.5 x 2.0 ■
	6.2/379†	1.57	.12	479	6.2	5 x 20 x 2.87 ■
P30/3500 (Exc. Motor Home Chassis)	4.8/292	.98	.16	447	3.5	5 x 19 x 2.5 ■
	5.7/350	.98	.16	481	4.0	5 x 19.5 x 2.18 ■
	6.2/379	1.57	.12	646	6.2	5 x 19.5 x 2.88 ■
P30/3500 Motor Home Chassis*	7.4/454†	2.17	.10	537	5.7	7 x 19.5 Flex ■
	6.2/379†	2.17	.10	537	7.0	5 x 19.5 x 2.88 ■

*Down-flow type radiator. †Automatic transmission standard. ▲.16 with LH6; .12 with LL4. #.16 on G10/1500 models.

★Capacity (approx.) shown with standard heater (except P20-30 models) and standard coolant recovery system.

■ Temperature controlled clutch fan. § All models with automatic transmissions include a transmission oil cooler integral with the radiator. †.12 with 4.10, 4.56 axle ratio (except V30/3500 models). ♦.12 with 3.73 axle ratio. *2.56 on V10/1500 models.

COOLING SYSTEMS

OPTIONAL COOLING SYSTEMS

§TUBE AND CENTER CROSS-FLOW-TYPE RADIATOR WITH
MULTILOUVER DESIGN AND 15 LB. PRESSURE CAP.

Series	Optional Combinations			Radiator			System Capacity (gal) ★	Fan (No. blades x diam. x pitch)
	Engine (Liter/Cu. In.)	Option	Transmission Type	Thick-ness (in)	Dist. Between Tubes (Const) (in)	Frontal Area (sq in)		
ASTRO/SAFARI	2.5/151		Automatic	.93	.18	358	2.3	4 x 16 x 1.26
		HD Cooling	Manual	.93	.16	358	2.3	4 x 16 x 1.26
			Automatic	.93	.14	358	2.3	4 x 16 x 1.26
	4.3/262	Air Conditioning	Manual	.93	.16	358	2.3	5 x 16 x 2.83 ■
			Automatic	.93	.14	358	2.3	5 x 16 x 2.83 ■
		HD Cooling	Automatic	.93	.18	407	3.4	3 x 18 x 2.71 ■
			Manual	.93	.12	407	3.4	3 x 18 x 2.71 ■
		Air Conditioning	Automatic	.93	.12	407	3.4	3 x 18 x 2.71 ■
			Manual	.93	.12	407	3.4	5 x 19 x 2.6 ■
		Trans. Oil Cooler, Engine Oil Cooler	Automatic	.93	.12	407	3.4	5 x 19 x 2.6 ■
S-10/15	2.5/151	HD Cooling	Automatic	.98	.18	292	2.9	4 x 14.49 x 1.26
			Manual	.98	.16	350	3.0	4 x 14.49 x 1.26
			Automatic	.98	.16	350	3.0	4 x 14.49 x 1.26
		Air Conditioning	Manual	.98	.16	350	3.0	5 x 16.93 x 2.64
			Automatic	.98	.14	350	3.0	5 x 16.93 x 2.64 ■
	2.8/173		Automatic	.98	.18	350	2.9	5 x 15.0 x 2.05 ■
		Trans. Oil Cooler, Engine Oil Cooler Trailing Special	Automatic	.98	.12	350	2.8	5 x 16.0 x 2.83 ■
		Air Conditioning, HD Cooling	Manual	.98	.16	350	2.8	5 x 16.0 x 2.83 ■
	Automatic		.98	.14	350	2.8	5 x 15.0 x 2.83 ■	
	4.3/262	Air Conditioning, HD Cooling or Engine Oil Cooler	Automatic	1.34	.16	395	3.5	5 x 19 x 2.5 ■
Trans. Oil Cooler, Engine Oil Cooler or Trailing Special		Automatic	1.34	.14	395	3.5	5 x 19 x 2.5 ■	
C/K 1500	4.3/262		Automatic	.93	.10	358	3.6	3 x 19 x 2.0 ■
		HD Radiator, Air Conditioning	Manual	1.34	.12	358	3.6	5 x 19.5 x 2.0 ■
			Automatic	1.34	.10	358	3.6	5 x 19.5 x 2.0 ■
		Trans. Oil Cooler	Automatic	1.34	.10	358	3.6	5 x 19.5 x 2.0 ■
		Trans. Oil Cooler, Engine Oil Cooler	Automatic	1.34	.12	358	3.6	5 x 19.5 x 2.0 ■
	5.0/305		Automatic	1.34	.12	358	3.8	3 x 19 x 2.0 ■
		HD Radiator Air Conditioning	Manual	1.34	.14	488	3.8	3 x 19 x 2.0 ■
			Automatic	1.34	.14	488	3.9	5 x 19.5 x 2.0 ■
		Trans. Oil Cooler	Automatic	1.34	.14	488	3.9	5 x 19.5 x 2.0 ■
	Trans. Oil Cooler, Engine Oil Cooler	Automatic	1.34	.10	488	3.9	5 x 19.5 x 2.0 ■	

★ Capacity (approx.) shown with standard heater and standard coolant recovery system. ■ Temperature-controlled clutch fan.
§All models with automatic transmissions include a transmission oil cooler integral with the radiator.

COOLING SYSTEMS

OPTIONAL COOLING SYSTEMS (Continued)

**§TUBE AND CENTER CROSS-FLOW-TYPE RADIATOR WITH
MULTILOUVER DESIGN AND 15 LB. PRESSURE CAP.**

Series	Optional Combinations			Radiator			System Capacity (gal) ★	Fan (No. blades x diam. x pitch)
	Engine (Liter/Cu. In.)	Option	Transmission Type	Thickness (in)	Dist. Between Tubes (Const) (in)	Frontal Area (sq in)		
C/K 1500 (Con't)	5.7/350		Automatic	1.34-	.12	358	3.8	3 x 19 x 2.0 ■
		HD Radiator	Manual	1.34	.16	488	4.0	5 x 19.5 x 2.0 ■
			Automatic	1.34	.14	488	3.9	5 x 19.5 x 2.0 ■
		HD Radiator, Trans. Oil Cooler	Automatic	1.34	.14	488	3.9	5 x 19.5 x 2.0 ■
		Trans. Oil Cooler, Engine Oil Cooler	Automatic	1.34	.10	488	3.9	5 x 19.5 x 2.0 ■
		Air Conditioning	Manual	1.34	.16	488	4.0	5 x 19.5 x 2.0 ■
	Automatic		1.34	.10	488	3.9	5 x 19.5 x 2.0 ■	
	6.2/379		Automatic	1.58	.10	576	6.2	5 x 20 x 2.56 ■
		Air Conditioning	Manual	1.58	.12	576	6.2	5 x 20 x 2.56 ■
			Automatic	1.58	.10	576	6.2	5 x 20 x 2.56 ■
			Trans. Oil Cooler	Automatic	2.17	.08	576	6.2
		Air Conditioning, Trans. Oil Cooler	Automatic	2.17	.08	576	5.2	5 x 20 x 2.56 ■
R10/1500	5.7/350		Automatic	.98#	.14▲	479	4.2	3 x 19 x 2.56 ■
		HD Radiator	Automatic	1.57	.16@	537	4.3	3 x 19 x 2.56 ■
		HD Radiator, Trans. Oil Cooler	Automatic	1.57	.16@	537	4.3	3 x 19 x 2.56 ■
		Air Conditioning, Trans. Oil Cooler	Automatic	1.57	.14	537	4.3	5 x 19.5 x 2.18 ■
		Air Conditioning	Automatic	1.57	.16@	537	4.3	5 x 19.5 x 2.18 ■
	6.2/379	Air Conditioning	Manual	1.57	.16*	646	6.2	5 x 20 x 2.87 ■
			Automatic	1.57*	.12@	646	6.2	5 x 20 x 2.87 ■
		Trans. Oil Cooler	Automatic	1.57	.12	646	6.2	5 x 20 x 2.87 ■
		Air Conditioning, Trans. Oil Cooler	Automatic	1.57*	.12	646	6.2	5 x 20 x 2.87 ■
			Automatic	1.57	.12	646	6.2	5 x 20 x 2.87 ■
G10/1500	4.3/262		Automatic	.93	.14	358	3.4	3 x 19 x 2.0 ■
		Air Conditioning, HD Cooling	Automatic	.93	.10	358	3.3	5 x 19.5 x 2.0 ■
		Trans. Oil Cooler, Engine Oil Cooler	Automatic	1.57	.12	352	3.4	3 x 19 x 2.0 ■
	5.0/305		Automatic	.98	.16	479	4.2	3 x 19 x 2.0 ■
		Air Conditioning, HD Cooling	Manual	.98	.16	479	4.3	5 x 19.5 x 2.0 ■
			Automatic	.98	.12	479	4.2	5 x 19.5 x 2.0 ■
		Trans. Oil Cooler	Automatic	1.57	.10	479	4.2	5 x 19.5 x 2.0 ■
	5.7/350		Automatic	.98	.16	479	4.2	3 x 19 x 2.0 ■
		Air Conditioning, HD Cooling	Automatic	1.57	.16	479	4.2	5 x 19.5 x 2.0 ■
		Trans. Oil Cooler	Automatic	1.57	.10	479	4.2	5 x 19.5 x 2.0 ■
V10/1500	5.7/350		Automatic	.98#	.14▲	479	4.3	3 x 19 x 2.56 ■
		HD Radiator	Manual	1.57	.16	479	4.3	3 x 19 x 2.56 ■
			Automatic	1.57	.16@	537	4.2	3 x 19 x 2.56 ■
		HD Radiator, Trans. Oil Cooler	Automatic	1.57	.16@	537	4.2	3 x 19 x 2.56 ■
		Air Conditioning, Trans. Oil Cooler	Automatic	1.57	.14	537	4.2	5 x 19.5 x 2.18 ■
		Air Conditioning	Manual	.98	.12	479	4.3	5 x 19.5 x 2.18 ■
			Automatic	1.57	.16@	537	4.5	5 x 19.5 x 2.18 ■

★ Capacity (approx.) shown with standard heater and standard coolant recovery system. ■ Temperature-controlled clutch fan.
 #1.57 with 3.42, 3.73 axle ratio. @.14 with 3.73 axle ratio. *.12 with 3.73 axle ratio. *2.17 with 3.42, 3.73 axle ratio.
 §All models with automatic transmissions include a transmission oil cooler integral with the radiator. ▲.16 with 3.42, 3.73 axle ratio.

COOLING SYSTEMS

OPTIONAL COOLING SYSTEMS (Continued)

§TUBE AND CENTER CROSS-FLOW-TYPE RADIATOR WITH
MULTILOUVER DESIGN AND 15 LB. PRESSURE CAP.

Series	Optional Combinations			Radiator			System Capacity (gal) ★	Fan (No. blades x diam. x pitch)
	Engine (Liter/Cu. In.)	Option	Transmission Type	Thickness (in)	Dist. Between Tubes (Const) (in)	Frontal Area (sq in)		
V10/1500 (Con't)	6.2/379	Air Conditioning	Manual	1.57	.16	646	6.2	5 x 20 x 2.87 ■
			Automatic	1.57*	.12@	646	6.2	5 x 20 x 2.87 ■
		Trans. Oil Cooler	Automatic	1.57	.12	646	6.2	5 x 20 x 2.87 ■
		Air Conditioning, Trans. Oil Cooler	Automatic	1.57*	.12	646	6.2	5 x 20 x 2.87 ■
R20/2500	5.7/350		Automatic	1.57	.16†	537	4.3	3 x 19 x 2.56 ■
		HD Radiator/LT9	Manual	.98*	.12¢	479	4.3	3 x 19 x 2.71 ■
		Air Conditioning/LS9	Automatic	1.57	.16	537	4.3	5 x 19.5 x 2.18 ■
		Air Conditioning/LT9	Manual	.98*	.12¢	479	4.3	5 x 19.5 x 2.18 ■
			Automatic	1.57	.16▲	537	4.3	5 x 19.5 x 2.18 ■
		Trans. Oil Cooler	Automatic	1.57	.16▲	537	4.3	3 x 19 x 2.56 ■
	7.4/454		Automatic	2.17	.12	537	6.1	5 x 19.5 x 2.18 ■
		HD Radiator	Manual	1.57	.12	537	5.4	5 x 19.5 x 2.18 ■
		Air Conditioning, Trans. Oil Cooler	Manual	2.17	.14	537	5.4	7 x 19.5 x 2.87 ■◆
			Automatic	2.17	.12	537	6.1	7 x 19.5 x 2.87 ■◆
	6.2/379 LH6		Automatic	1.57	.16*	646	6.2	5 x 20 x 2.87 ■
		Air Conditioning	Manual	1.57	.16	646	6.2	5 x 20 x 2.87 ■
			Automatic	1.57††	.12@	646	6.2	5 x 20 x 2.87 ■
		Trans. Oil Cooler	Automatic	1.57	.12	646	6.2	5 x 20 x 2.87 ■
	6.2/379 LL4		Automatic	2.17	.14	646	6.2	5 x 20 x 2.87 ■
		Air Conditioning, Trans. Oil Cooler	Manual	2.17#	.14\$	646	6.2	5 x 20 x 2.87 ■
Automatic			2.17	.12	646	6.2	5 x 20 x 2.87 ■	
		Automatic	2.17	.14	646	6.2	5 x 20 x 2.87 ■	
G20/2500	4.3/262		Automatic	.93	.14	358	3.4	3 x 19 x 2.0 ■
		Air Conditioning, HD Cooling	Manual	.93	.14	358	3.3	5 x 19.5 x 2.0 ■
			Automatic	.93	.10	358	3.3	5 x 19.5 x 2.0 ■
	5.0/305	Engine Oil Cooler & Trans. Oil Cooler	Automatic	1.57	.12	352	3.4	3 x 19 x 2.0 ■
			Automatic	.98	.12	479	4.2	3 x 19 x 2.0 ■
		Air Conditioning, HD Cooling	Manual	.98	.16	479	4.3	5 x 19.5 x 2.0 ■
			Automatic	.98	.12	479	4.2	5 x 19.5 x 2.0 ■
		Engine Oil Cooler & Trans. Oil Cooler	Automatic	1.57	.10	479	4.5	3 x 19 x 2.0 ■
			Trans. Oil Cooler	Automatic	1.57	.10	479	4.2
		5.7/350		Automatic	.98	.12	479	4.2
	Air Conditioning, HD Cooling		Automatic	1.57	.16	479	4.2	5 x 19.5 x 2.0 ■
	Engine Oil Cooler & Trans. Oil Cooler		Automatic	1.57	.10	479	4.5	3 x 19 x 2.0 ■
	Trans. Oil Cooler		Automatic	1.57	.10	479	4.2	3 x 19 x 2.0 ■
	6.2/379		Automatic	1.57	.12	479	6.2	5 x 20 x 2.87 ■
		Air Conditioning, HD Cooling	Manual	1.57	.12	479	6.3	5 x 20 x 2.87 ■
			Automatic	1.57	.12	479	6.2	5 x 20 x 2.87 ■

★ Capacity (approx.) shown with standard heater and standard coolant recovery system.

■ Temperature-controlled clutch fan. ◆ RPM controlled flex fan. # 1.57 with 3.42, 3.73 axle ratio. @ .14 with 3.73 axle ratio.

• .12 with 3.73 axle ratio. †† 2.17 with 3.73 axle ratio. \$.12 with 3.42, 3.73 axle ratio. † .14 with 4.56 axle ratio.

* 1.57 with 4.10, 4.56 axle ratio. ¢ .16 with 4.10 axle ratio; .14 with 4.56 axle ratio. ▲ .14 with 4.56 axle ratio.

§ All models with automatic transmissions include a transmission oil cooler integral with the radiator.

COOLING SYSTEMS

OPTIONAL COOLING SYSTEMS (Continued)

§TUBE AND CENTER CROSS-FLOW-TYPE RADIATOR WITH
MULTILOUVER DESIGN AND 15 LB. PRESSURE CAP.

Series	Optional Combinations			Radiator			System Capacity (gal) ★	Fan (No. blades x diameter x pitch)	
	Engine (Liter/Cu. In.)	Option	Transmission Type	Thickness (in)	Dist. Between Tubes (Const.) (in)	Frontal Area (sq in)			
V20/2500	5.7/350		Automatic	1.57	.16†	537	4.3	3 x 19 x 2.56 ■	
		HD Radiator	Manual	.98	.12(a)%	479	4.3	3 x 19 x 2.56 ■	
		Air Conditioning	Manual	.98	.12(a)%	479	4.3	5 x 19.5 x 2.18 ■	
			Automatic	1.57	.16%	537	4.3	5 x 19.5 x 2.18 ■	
		Trans. Oil Cooler	Automatic	1.57	.16%	537	4.3	3 x 19 x 2.56 ■	
	6.2/379 LH6		Automatic	1.57	.16•	646	6.2	5 x 20 x 2.87 ■	
		Air Conditioning	Manual	1.57	.16	646	6.2	5 x 20 x 2.87 ■	
			Automatic	1.57††	.12@	646	6.2	5 x 20 x 2.87 ■	
	Trans. Oil Cooler	Automatic	1.57††	.12	646	6.2	5 x 20 x 2.87 ■		
	6.2/379 LL4		Automatic	2.17	.14	646	6.2	5 x 20 x 2.87 ■	
		Air Conditioning, Trans. Oil Cooler	Manual	2.17#	.14§	646	6.2	5 x 20 x 2.87 ■	
			Automatic	2.17	.12	646	6.2	5 x 20 x 2.87 ■	
C/K 2500	4.3/262		Automatic	.93	.10	358	3.4	3 x 19 x 2.0 ■	
		HD Radiator	Manual	1.34	.12	358	3.4	5 x 19.5 x 2.0 ■	
			Automatic	1.34	.10	358	3.4	5 x 19.5 x 2.0 ■	
		Air Conditioning	Manual	1.34	.12	358	3.4	5 x 19.5 x 2.0 ■	
			Automatic	1.34	.10	358	3.4	5 x 19.5 x 2.0 ■	
		Trans. Oil Cooler	Automatic	1.34	.10	358	3.8	5 x 19.5 x 2.0 ■	
		Trans. Oil Cooler, Engine Oil Cooler	Automatic	1.34	.12	358	3.9	5 x 19.5 x 2.0 ■	
		5.0/305		Automatic	.93	.12	358	4.2	3 x 19 x 2.0 ■
			HD Radiator	Manual	.93	.14	488	4.2	5 x 19.5 x 2.0 ■
				Automatic	.93	.12	488	4.2	5 x 19.5 x 2.0 ■
	Air Conditioning		Manual	.93	.14	488	4.2	5 x 19.5 x 2.0 ■	
			Automatic	.93	.12	488	4.2	5 x 19.5 x 2.0 ■	
	Trans. Oil Cooler		Automatic	1.34	.14	488	4.2	5 x 19.5 x 2.0 ■	
	Trans. Oil Cooler, Engine Oil Cooler	Automatic	1.34	.10	488	3.9	5 x 19.5 x 2.0 ■		
	5.7/350		Automatic	1.34	.12	358	3.8	3 x 19 x 2.0 ■	
		HD Radiator	Manual	1.34	.16	488	4.0	5 x 19.5 x 2.0 ■	
			Automatic	1.34	.14	488	3.9	5 x 19.5 x 2.0 ■	
		HD Radiator, Trans. Oil Cooler	Automatic	1.34	.14	488	3.9	5 x 19.5 x 2.0 ■	
		Trans. Oil Cooler, Engine Oil Cooler	Automatic	1.34	.10	488	3.9	5 x 19.5 x 2.0 ■	
		Air Conditioning	Manual	1.34	.16	488	4.0	5 x 19.5 x 2.0 ■	
			Automatic	1.34	.10	488	3.9	5 x 19.5 x 2.0 ■	
		6.2/379		Automatic	1.58	.10	576	6.2	5 x 20 x 2.56 ■
			Air Conditioning	Manual	1.58	.12	576	6.2	5 x 20 x 2.56 ■
				Automatic	1.58	.10	576	6.2	5 x 20 x 2.56 ■
	Trans. Oil Cooler		Automatic	2.17	.08	576	6.2	5 x 20 x 2.56 ■	
	Air Conditioning, Trans. Oil Cooler	Automatic	2.17	.08	576	5.2	5 x 20 x 2.56 ■		

★ Capacity (approx.) shown with standard heater (except P20-30 models) and standard coolant recovery system.

■ Temperature-controlled clutch fan. ††2.17 with 3.73 axle ratio.

(a).16 with 4.10 axle ratio. % .14 with 4.56 axle ratio.

\$.12 with 3.42, 3.73 axle ratio. @.14 with 3.73 axle ratio. #1.57 with 3.42, 3.73 axle ratio. •.12 with 3.73 axle ratio.

§ All models with automatic transmissions include a transmission oil cooler integral with the radiator.

COOLING SYSTEMS

OPTIONAL COOLING SYSTEMS (Continued)

§TUBE AND CENTER CROSS-FLOW-TYPE RADIATOR WITH
MULTILOUVER DESIGN AND 15 LB. PRESSURE CAP.

Series	Optional Combinations			Radiator			System Capacity (gal) ★	Fan (No. blades x diam. x pitch)
	Engine (Liter/Cu. In.)	Option	Transmission Type	Thickness (in)	Dist. Between Tubes (Const.) (in)	Frontal Area (sq in)		
P20/2500	4.8/292		Automatic	.98	.12	481	3.5	5 x 19 x 2.0 ■
			Manual	.98	.16	481	3.5	5 x 19.5 x 2.18 ■
	5.7/350	HD Radiator	Automatic	.98	.12	481	3.5	5 x 19.5 x 2.18 ■
		Air Conditioning, HD Radiator	Automatic	1.57	.12	481	3.9	5 x 19.5 x 2.18 ■
			Manual	1.57	.12	537	3.9	5 x 19.5 x 2.18 ■
	6.2/379		Automatic	1.57	.12	537	3.9	5 x 19.5 x 2.18 ■
R30/3500	4.8/292		Automatic	1.57	.16	445	3.8	3 x 19 x 2.56 ■
		HD Radiator	Manual	.98	.12	445	3.8	3 x 19 x 2.56 ■
		Air Conditioning	Manual	1.57	.16	479	3.9	5 x 19.5 x 2.18 ■
			Automatic	1.57	.14	479	3.8	5 x 19.5 x 2.18 ■
	5.7/350		Automatic	1.57	.16%	537	4.3	3 x 19 x 2.71 ■
		HD Radiator	Manual	.98(b)	.12(a)%	479	4.3	3 x 19 x 2.71 ■
		Air Conditioning, Trans. Oil Cooler	Manual	.98(b)	.12(a)%	479	4.3	5 x 19.5 x 2.18 ■
	Automatic		1.57	.16%	537	4.3	5 x 19.5 x 2.18 ■	
	7.4/454		Automatic	2.17	.12	537	6.1	5 x 19.5 x 2.18 ■
		HD Radiator	Manual	1.57	.12	537	5.4	5 x 19.5 x 2.18 ■
		Air Conditioning, Trans. Oil Cooler	Manual	2.17	.14	537	5.4	7 x 19.5 x 2.87 ■ ♦
			Automatic	2.17	.12	537	6.0	7 x 19.5 x 2.87 ■ ♦
	6.2/379		Automatic	2.17	.14	646	6.2	5 x 20 x 2.87 ■
		Air Conditioning, Trans. Oil Cooler	Manual	2.17#	.14§	646	6.2	5 x 20 x 2.87 ■
Automatic			2.17	.12	646	6.2	5 x 20 x 2.87 ■	
G30/3500 (05) w/o C6P	4.3/262		Automatic	.93	.14	358	3.4	3 x 19 x 2.0 ■
		Air Conditioning, HD Cooling	Automatic	.93	.10	358	3.3	5 x 19.5 x 2.0 ■
		Engine Oil Cooler & Trans. Oil Cooler	Automatic	1.57	.12	352	3.4	3 x 19 x 2.0 ■
G30/3500 (06) w/o C6P G30/3500/C6P(05,06)	5.7/350		Automatic	.98	.12	479	4.2	5 x 19.5 x 2.0 ■
		Air Conditioning, HD Cooling	Automatic	1.57	.12	479	4.2	5 x 19.5 x 2.0 ■
		Engine Oil Cooler & Trans. Oil Cooler	Automatic	1.57	.10	479	4.5	5 x 19.5 x 2.0 ■
		Trans. Oil Cooler	Automatic	1.57	.10	479	4.2	5 x 19.5 x 2.0 ■
	6.2/379	Air Conditioning	Automatic	2.17	.10	479	6.2	5 x 20 x 2.87 ■
G30/3500 (03-32)	5.7/350	Air Conditioning, HD Cooling	Automatic	1.57	.12	479	4.2	5 x 19.5 x 2.0 ■
		Engine Oil Cooler, & Trans. Oil Cooler	Automatic	1.57	.10	479	4.5	5 x 19.5 x 2.0 ■
		Trans. Oil Cooler	Automatic	1.57	.10	479	4.2	5 x 19.5 x 2.0 ■
	6.2/379	Air Conditioning	Automatic	2.17	.10	479	6.2	5 x 20 x 2.87 ■

★ Capacity (approx.) shown with standard heater (except P20-30 models) and standard coolant recovery system.

■ Temperature-controlled clutch fan. ♦ RPM controlled flex fan. (a) .16 with 4.10 axle ratio. % .14 with 4.56 axle ratio.

(b) 1.57 with 4.10, 4.56 axle ratio.

§ .12 with 3.42, 3.73 axle ratio.

§ All models with automatic transmissions include a transmission oil cooler integral with the radiator #1.57 with 3.42, 3.73 axle ratio.

COOLING SYSTEMS

OPTIONAL COOLING SYSTEMS (Continued)

§TUBE AND CENTER CROSS-FLOW-TYPE RADIATOR WITH
MULTILOUVER DESIGN AND 15 LB. PRESSURE CAP.

Series	Optional Combinations			Radiator			System Capacity (gal) ★	Fan (No. blades x diam. x pitch)
	Engine (Liter/Cu. In.)	Option	Transmission Type	Thickness (in)	Dist. Between Tubes (Const.) (in)	Frontal Area (sq in)		
V30/3500	4.8/292		Automatic	1.57	.16	445	3.8	3 x 19 x 2.56 ■
		HD Radiator	Manual	.98	.12	445	3.8	3 x 19 x 2.56 ■
		Air Conditioning	Manual	1.57	.16	479	3.9	5 x 19.5 x 2.18 ■
			Automatic	1.57	.14	479	3.8	5 x 19.5 x 2.18 ■
	5.7/350		Automatic	1.57	.16%	537	4.3	3 x 19 x 2.71 ■
		HD Radiator	Manual	.98(b)	.12(a)%	479	4.3	3 x 19 x 2.71 ■
		Air Conditioning, Trans. Oil Cooler	Manual	.98(b)	.12(a)%	479	4.3	5 x 19.5 x 2.18 ■
			Automatic	1.57	.16%	537	4.3	5 x 19.5 x 2.18 ■
	7.4/454		Automatic	2.17	.12	537	6.1	5 x 19.5 x 2.18 ■
		HD Radiator	Manual	1.57	.12	537	5.4	5 x 19.5 x 2.18 ■
		Air Conditioning, Trans. Oil Cooler	Manual	2.17	.14	537	6.2	7 x 19.5 x 2.87 ■ ♦
			Automatic	2.17	.12	537	6.1	7 x 19.5 x 2.87 ■ ♦
	6.2/379		Automatic	2.17	.14	646	6.2	5 x 20 x 2.87 ■
		Air Conditioning, Trans. Oil Cooler	Manual	2.17(c)	.14§	646	6.2	5 x 20 x 2.87 ■
			Automatic	2.17	.12	646	6.2	5 x 20 x 2.87 ■
C/K 3500	5.7/350		Automatic	1.34	.10	488	3.8	5 x 19.5 x 2.0 ■
		HD Radiator	Manual	1.34	.16	488	3.8	5 x 19.5 x 2.0 ■
		Air Conditioning, Trans. Oil Cooler	Manual	1.34	.16	488	4.0	5 x 19.5 x 2.0 ■
			Automatic	1.34	.10	488	3.9	5 x 19.5 x 2.0 ■
	7.4/454		Automatic	2.17	.10	576	6.3	5 x 20 x 2.56 ■
		HD Radiator	Manual	2.17	.10	576	6.3	5 x 20 x 2.56 ■
		Air Conditioning	Manual, Automatic	2.17	.10	576	6.3	5 x 20 x 2.56 ■
		Air Conditioning, Trans. Oil Cooler	Automatic	2.17	.10	576	6.2	5 x 20 x 2.56 ■
		Trans. Oil Cooler, Engine Oil Cooler	Automatic	2.17	.10	576	6.2	5 x 20 x 2.56 ■
			Automatic	2.17	.10	576	6.2	5 x 20 x 2.56 ■
	6.2/379		Automatic	1.58	.10	576	6.2	5 x 20 x 2.56 ■
		Air Conditioning, Trans. Oil Cooler	Manual, Automatic	2.17	.08	576	6.2	5 x 20 x 2.56 ■
P30/3500 (Except Motor Home Chassis)	4.8/292	HD Radiator	Automatic	.98	.12	481	3.5	5 x 19 x 2.5 ■
			Manual	.98	.16	481	3.5	5 x 19.5 x 2.18 ■
			Automatic	.98	.12	481	3.5	5 x 19.5 x 2.18 ■
	5.7/350	Air Conditioning HD Radiator	Automatic	1.57	.12	481	3.9	5 x 19.5 x 2.18 ■
			Manual	1.57	.12	537	3.9	5 x 19.5 x 2.18 ■
			Automatic	1.57	.12	537	3.9	5 x 19.5 x 2.18 ■
	6.2/379		Automatic	1.57	.12	646	6.1	5 x 19.5 x 2.88 ■

★ Capacity (approx.) shown with standard heater (except P20-30 models) and standard coolant recovery system.

■ Temperature-controlled clutch fan. ♦ RPM controlled flex fan. (a) .16 with 4.10 axle ratio. % .14 with 4.56 axle ratio.

(b) 1.57 with 4.10, 4.56 axle ratio. (c) 1.57 with 3.42, 3.73 axle ratio. § .12 with 3.42, 3.73 axle ratio.

§ All models with automatic transmissions include a transmission oil cooler integral with the radiator

FUEL TANKS

SPECIFICATIONS

Series	Tank Location	Std/ Opt	Approx. Tank Cap. (gallons)	Filler Location	Description
†Blazer/Jimmy; Pickups; Suburban; Chassis-Cab Models					
El Camino/Caballero	Behind rear axle	Std	17.7	Left Side	Rectangular
		Opt	22	Left Side	Rectangular
S-10/15 Models	Inboard LH frame rail	#Std	13.2	Left Side	Rectangular
		Std	20.0	Left Side	Step-shape Rectangle
C/K 1500-3500	Inboard LH frame rail	Std	25	Left Side	Rectangular
		@Opt	34	Left Side	Step-shape Rectangular
V10/1500 Blazer/Jimmy	Inboard frame behind rear axle	Std	♦31	Right Side (Rear)	Rectangular
R/V10/1500-20/2500 Suburban	Inboard frame behind rear axle	Std	♦31	Right Side (Rear)	Rectangular
		Opt	★40	Right Side (Rear)	Rectangular
R20943 R/V30903-43 R/V31003, R/V31403	Outboard LH frame rail	Std	20	Left Center	Step-shape Rectangle
	Outboard RH frame rail	Opt	20	Right Center	Step-shape Rectangle
†Astro/Safari; Chevy Van/Vandura; Sportvan/Rally; Cutaway Van; Hi-Cube Van					
Astro/Safari	Between frame rails forward of rear axle	Std	17	Left Side	Rectangular
		Opt	27	Left Side	Rectangular
G10/1500-20/2500; G30/3500 (06)	Between frame rails behind rear axle	Std	22	Left Rear	Rectangular
		Opt	33	Left Rear	Rectangular
G30/3500 (05)	Between frame rails behind rear axle	Std	22	Left Rear	Rectangular
		Opt	33	Left Rear	Rectangular
G30/3500 (03)	Between frame rails behind rear axle	Std	22	Left Rear	Rectangular
		Opt**	33	Left Rear	Rectangular
Forward Control Models					
P20/2500; P30/3500	Between frame rails behind rear axle	Std	40	Left Rear	Rectangular
P30/3500 Motor Home Chassis*	Between frame rails behind rear axle	Std	40	Left Rear	Rectangular

*P30/3500 Motor Home Chassis has temporary 5 qt fuel tank connected for shipping purposes.

**Std on RV Cutaway Van.

†All Light Duty Emissions and California Heavy Duty Emission vehicles are equipped with evaporative emission controls.

#Standard only on EL/Special model, or when 2000-lb Payload is ordered.

@Not available on C/K 10703

♦Approximately 32 gallons with 6.2 Liter diesel engine

★Approximately 41 gallons with 6.2 Liter diesel engine.

EMISSION CONTROL EQUIPMENT

Light-Duty Emissions Systems (8500 lbs. GVWR and under)																
Engine	RPO	Application	PCV	EGR	ECS	CHA	AIR	EVRV	DFI	ESC	CDR	CL	ORC	EPR	SEGR	BPEGR
2.5 Liter 151 L4 EFI	LN8	Federal	X	X	X	X						X	X			X
		California	X	X	X	X						X	X			X
2.8 Liter 173 V6 EFI	LL2	Federal	X	X	X	X	X	X		X		X	X			
		California	X	X	X	X	X	X		X		X	X			
4.3 Liter 262 V6 EFI	LB4	Federal	X		X	X	X†			X		X	X			X
		California	X		X	X	X			X		X	X			X
5.0 Liter 305 V8 EFI	LO3	Federal	X		X	X	X			X		X	X			X
		California	X		X	X	X			X		X	X			X
▲5.7 Liter 350 V8 EFI	LO5	Federal	X		X	X	X			X		X	X			X
		California	X		X	X	X			X		X	X			X
▲7.4 Liter 454 V8 EFI	LI9	Federal	X	X	X	X	X	X				X	X			
		California	X	X	X	X	X	X				X	X			
6.2 Liter 379 V8 Diesel	LH6	Federal							X		X			X	X	
		California	Not Offered													

- "Federal" indicates required Emission Systems in all states except California;
- "California" refers to equipment required for California only.
- * Not used on Step-Van/Value Van or FC Chassis.
- † AIR used only with manual transmission
- ▲ This includes a Heavy Duty Emission engine (8500 to 10,000 lb.) certified as Light Duty and uses ORC system.

Heavy-Duty Emissions Systems (Over 10,000 lbs. GVWR)												
Engine	RPO	Application	PCV	EFE	ECS	EGR	CHA	AIR	TVSS	ISS	DFI	CDR
4.8 Liter 292 L6 1-bbl	L25	Federal	X	X	X		X	X	X	X		
		California	Not Offered									
5.7 Liter 350 V8 4-bbl	LT9	Federal	X	X	X	X	X	X†	X	X		
		California	X	X	X	X	X	X	X			
6.2 Liter 379 V8 Diesel	LL4	Nationwide									X	X
7.4 Liter 454 V8 4-bbl	LE8	Federal	X	X	X	X	X	X†	X	X		
		California	X	X	X	X	X	X	X	X		

†Two air pumps used #Also used on vehicles 8500 to 10,000 lbs. GVWR.

- | | |
|---|--|
| <ul style="list-style-type: none"> PCV—Positive Crankcase Ventilation EGR—Exhaust Gas Recirculation ECS—Evaporation Control System EFE—Early Fuel Evaporation CHA—Carburetor Heated Air CDR—Crankcase Depression Regulator SEGR—Switched Exhaust Gas Recirculation AIR—Air Injection Reactor System TVSS—Trapped Vacuum Spark System ISS—Idle Stop Solenoid | <ul style="list-style-type: none"> DFI—Diesel Fuel Injection ESC—Electronic Spark Control CL—Closed Loop ORC—Oxidizing-Reducing Converter EPR—Exhaust Pressure Regulator EVRV—Electronic Vacuum Regulator Valve ORC/OC—Oxidizing Reducing Converter/
Oxidizing Converter BPEGR—Back Pressure Exhaust Gas Recirculation |
|---|--|

EPA ESTIMATED MILEAGE LABELS

The Environmental Protection Agency now publishes estimated mileage figures for all vehicles up to 8500 lbs. GVWR. EPA mileage figures are not available for trucks over 8500 lbs. GVWR.

EPA ratings are *estimates*. The actual mileage you get will vary depending on the type of driving you do, your driving habits, your truck's condition and available equipment.

GM truck models which are rated at 8500 lbs. GVWR or below will have an EPA Fuel Economy Label affixed to the inside of the front passenger door window, readable from the outside of the vehicle. This label will list the estimated miles per gallon. It will also list that particular vehicle's VIN number, vehicle name, number of cylinders, engine displacement, carburetor (number of barrels), and type of transmission (manual or automatic).

GM light-duty trucks which will display this label are:

- Astro/Safari**
- S-10/15 Models**
- C/K1500-2500 Models**
- R10/1500 Suburbans**
- V10/1500 Suburban and Blazer/Jimmy**
- G10/1500-20/2500 Sportvan/Rally, Chevy Van/Vandura**
- G30/3500 Sportvan/Rally @ 7400-lb. GVWR**
- G30/3500 Chevy Van/Vandura @ 7100-lb. GVWR**

EMISSION CONTROL EQUIPMENT

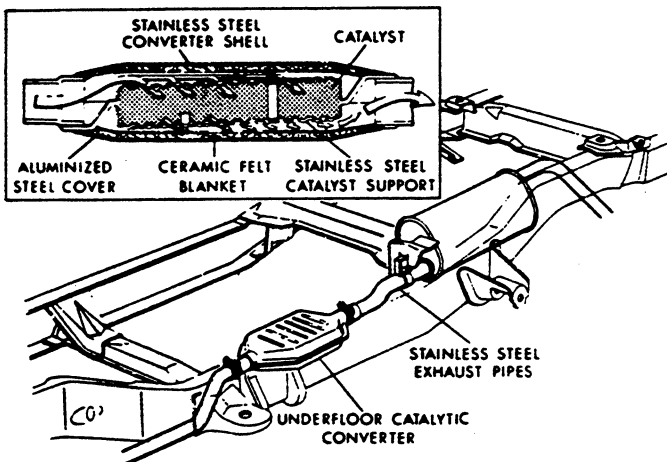

Oxidizing Reducing Converter (ORC) • Catalytic bed inside converter changes hydrocarbons and carbon monoxide to harmless emissions • Shell made of stainless steel with aluminized steel cover and ceramic felt insulation between • Exhaust pipe ahead of converter also is stainless steel • Catalytic emissions control allows tuning engines for increased fuel economy, improved drivability • Use of unleaded fuel promotes spark plug life, allows longer intervals between recommended oil changes.

The catalytic converter also contains a thin layer of Rhodium, which causes undesirable oxides of nitrogen (NO_x) to break down into acceptable emission components.

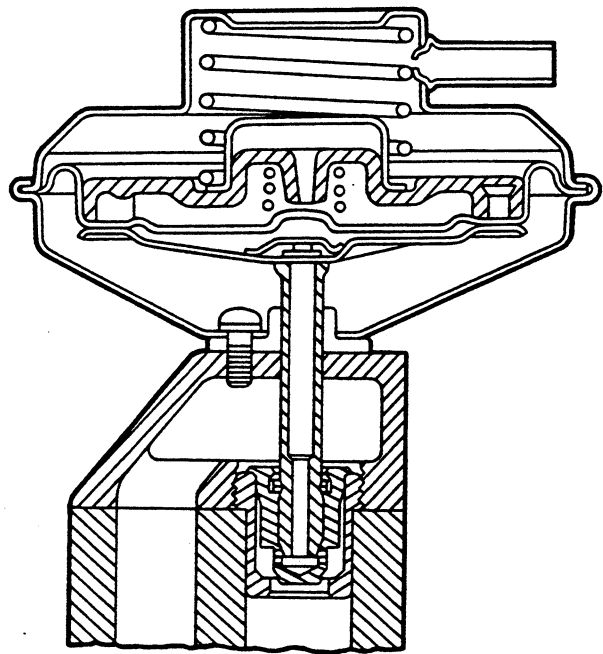

Exhaust Gas Recirculation (EGR) • Introduces exhaust gases to engine induction system through passages cast into intake manifold • Lowers combustion temperatures, reduces formation of nitrogen oxide • Controlled by manifold vacuum and exhaust back pressure • Normally closed at idle.

Throttle Return Control (TRC) • Reduces hydrocarbon and carbon monoxide emissions while vehicle is "coasting" • Throttle-lever actuator on carburetor opens primary venturi a pre-set amount over curb idle • Controlled by high manifold vacuum during extended overrun.

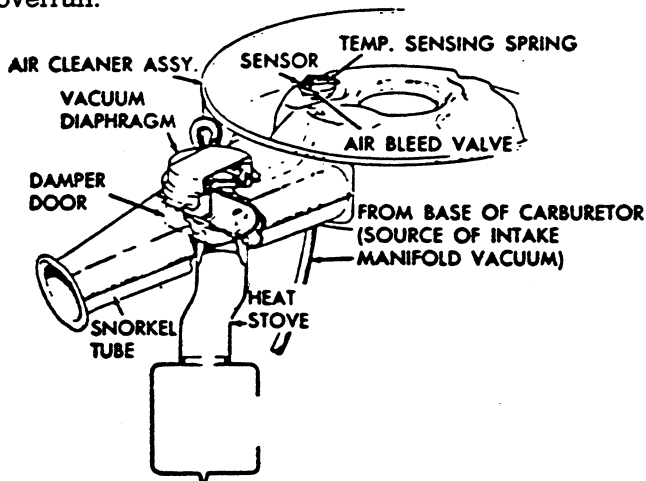

Carburetor Heated Air (CHA) • Allows significantly leaner carburetor calibration for reduced emissions • Heats carburetor air to 100°F when under-hood temperatures are lower • Damper door from exhaust manifold heat stove regulates heated air • Controlled by engine vacuum and bi-metallic thermostat on carbureted engines. EFI engines use wax pellet thermostat to control heated air • Minimizes carburetor icing and improves engine drivability during warm-up cycle.

- QUICKER ENGINE WARM UP
- IMPROVED DRIVEABILITY
- REDUCED EMISSIONS FOR WARM UP CYCLE

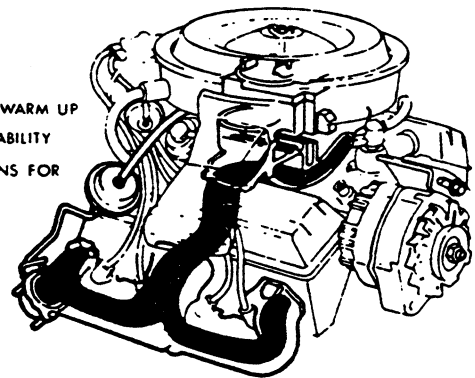

Early Fuel Evaporation (EFE) • Reduces exhaust emissions by preheating incoming fuel for improved combustion on L6 and V8 models • During cold starts, vacuum motor immediately closes exhaust manifold heat valve • Hot exhaust gases flow around inlet manifold and heat incoming fuel • More complete fuel evaporation during warm-up improves drivability. • On L4 and V6 models, an electric heating element located under the carburetor achieves the same as above.

*This system not used on EFI engines.

EMISSION CONTROL EQUIPMENT

GENERAL

Exhaust emissions are controlled on all gasoline powered truck models. Various systems are used depending on vehicle GVWR and the emission requirements. These systems employ aluminized or stainless steel exhaust system components.

ECM (computer) CONTROLLED ELECTRONIC FUEL INJECTION

This system is used on all series truck vehicles under 10,000-lbs. GVW (except P models with 4.8L engine). The ECM monitors signals from coolant temperature, manifold vacuum, exhaust oxygen sensor, throttle position sensor and engine cranking sensor. It controls the injectors to release and adjust the fuel to yield a near stoichiometric fuel-air mixture assuring engine operation compatible with emission requirements, optimum fuel economy and overall vehicle performance.

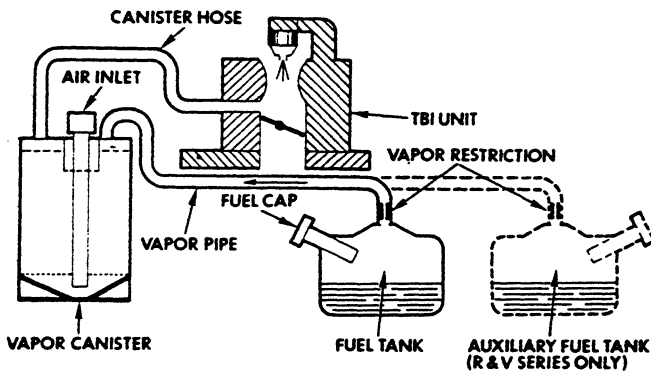

Carburetor type system shown above. EFI system is similar but simplified.

EVAPORATIVE EMISSION CONTROLS

All Series Truck models must include equipment to control fuel vapor emissions. Basically this system starts at the fuel tank by extending a line from the metering unit to the vapor storage canister. The metering unit is an integral unit which, in addition to fuel pickup and gage registration, provides: (a) Outlet for vapor to canister; (b) Fill limiting function; fuel fill venting; (c) Separation of vapor from liquid fuel and fuel return line inlet. A single line carries the vapors to a canister which stores the vapors when the engine is not running, but distributes the vapors to the carburetor when it is running. On R, V, G and P carbureted V8 engine models, carburetor fuel vapors are collected in an air cleaner carbon ring when the engine is not running.

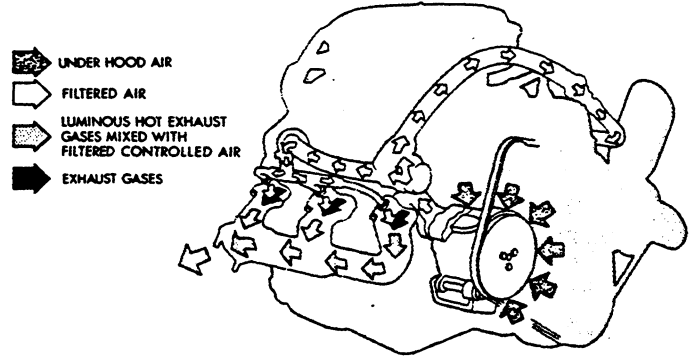

AIR INJECTION REACTOR (A.I.R.)

With this system, emissions of unburned hydrocarbons and carbon monoxide are controlled to levels specified by the Federal Motor Vehicle Air Pollution Control Act by injection of air into each exhaust valve port or into exhaust system before the converter. This provides oxygen to support combustion of the luminous hot exhaust gases and continues oxidation of unburned hydrocarbons and carbon monoxide in the exhaust system.

The system is comprised of an air pump, diverter valve and silencer, check valves, air manifold, thermostatically controlled air cleaner and modifications to the carburetor and ignition distributor. On vehicles with EFI, the ECM determines the proper mode of air control. Air for injection into the exhaust manifold is provided by a crankshaft-driven semi-articulated vane-type pump. Inlet air is cleaned by means of a centrifugal vane unit which separates dust particles and water from the air. The diverter valve functions as a pressure limiting valve which maintains a constant flow of air to the exhaust manifold. Check valves, one on six-cylinder engines and two on eight-cylinder engines, operate to prevent backflow of exhaust gases in event of pump or drive belt failure.

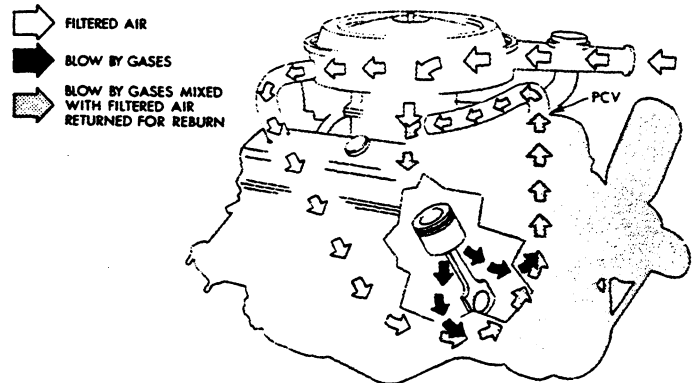

POSITIVE CRANKCASE VENTILATION (PCV)

All gasoline engines are equipped with PCV. This system prevents any crankcase emission being discharged into the atmosphere. It primarily consists of a completely sealed crankcase with a PCV valve and connections that returns blow-by gases to the combustion chamber where they are burned.



**1988 GENERAL MOTORS
CORPORATION**
INFORMATION REGARDING
**CONSUMER
INFORMATION
TRUCK-CAMPER
LOADING
1988 C/K MODELS**

PUBLISHED JANUARY, 1987

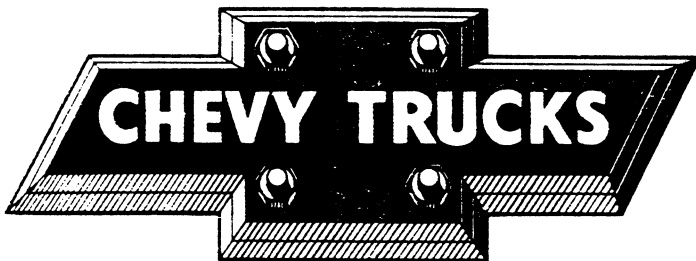

CHEVROLET MOTOR DIVISION
GENERAL MOTORS CORPORATION
WARREN, MICHIGAN 48090

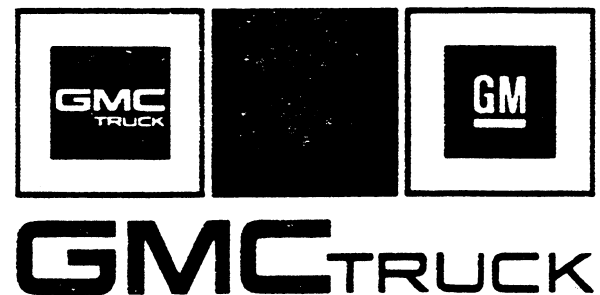

GMC TRUCK OPERATIONS
GENERAL MOTORS CORPORATION
PONTIAC, MICHIGAN 48058

1988 GENERAL MOTORS TRUCKS C/K MODELS

Consumer Information

Truck – Camper Loading

CONSUMER INFORMATION REGULATION 575.103 issued by the National Highway Traffic Safety Administration requires manufacturers of trucks capable of accommodating slide-in camper bodies to provide information concerning proper load and proper load distribution in truck-camper applications.

This Consumer Information booklet is designed to provide basic information relating to load capabilities of 1988 General Motors C/K Truck models which are adaptable to slide-in camper applications. Information contained herein is applicable to the truck buyer that already owns a 1988 General Motors C/K Truck or the prospective truck purchaser.

See the General Motors Corporation Light-Duty Truck Facts/Data Book for additional information required to completely spec out your vehicle for the proper slide-in camper accommodation.

The Regulation also provides that proper truck-camper loading information is to be maintained in truck dealerships and be made available to all prospects on request. This booklet relates to the 1988 General Motors C/K Truck models recommended for slide-in camper applications and is to be used as a consumer information piece.

Product specifications or data contained herein may change periodically. When a revision of this booklet is supplied to truck dealers, it is the dealers' responsibility to make the revised information available to the public.

All illustrations and specifications contained in this literature are based on the latest product information available at the time of publication approval. The right is reserved to make changes at any time in prices, colors, materials, equipment, specifications and models, and also to discontinue models.

TRUCK-CAMPER LOADING 1988 C/K MODELS

Consumer Information Regulation 575.103 requires manufacturers of trucks that would accommodate slide-in campers to specify the vehicles' Cargo Weight Rating (CWR) and the longitudinal limits within which the center of gravity for the cargo weight rating should be located.

Cargo Weight Rating (CWR)—The cargo weight rating of a vehicle means the value specified by the manufacturer as the cargo-carrying capacity of a vehicle, in pounds, exclusive of (minus) the weight of occupants, computed as 150 pounds times the number of designated seating positions.

Longitudinal Center of Gravity Zone for CWR (CG)—The forward limit of the recommended CG Zone is determined by the application of dimension "A" measured in inches from the rear of the truck bed. The rearward limit of the recommended CG Zone is established by application of dimension "B", also measured in inches from the rear of the truck bed. The recommended CG Zone lies between these points.

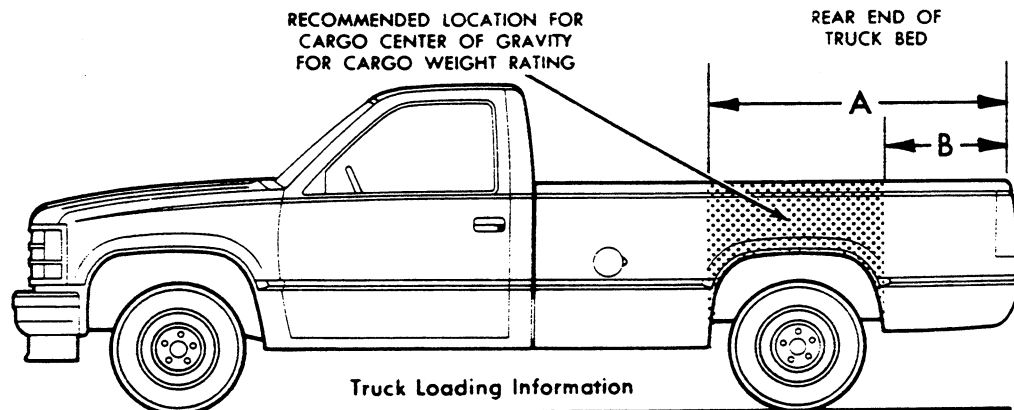

Model _____	Calculated Cargo Weight Rating _____
Dimension A _____	Dimension B _____

Limitations on Recommended CG Zones

FORWARD LIMIT

- | | |
|---|--|
| (1) Must not extend beyond the inside surface (dimension IL* shown on line drawings) of the pickup box. | (2) Must not exceed the front gross axle weight rating (GAWR). |
|---|--|

REARWARD LIMIT

- | | |
|--|--|
| (1) Must be no farther rearward than the inside surface (dimension IL* shown on line drawing) of the pickup box. | (3) Rear axle load limits:
C/K 1500—60% of GVWR
C/K 2500—65% of GVWR
C/K 3500—70% of GVWR |
| (2) Must not exceed the gross axle weight rating on the rear axle. | |

Vehicle (CG) Identification—All General Motors Corporation trucks that may be suitable for carrying a slide-in camper incorporate a Truck-Camper Loading information label located on the inside of the glove box door on C/K models. The vehicle identification number (VIN), the as-manufactured cargo weight rating (CWR) of that vehicle plus the CG limits of dimension "A" and "B" for that vehicle in inches are included.

Vehicle and Truck-Camper Loading are also discussed at length in the first few pages of the Vehicle Owner's Manual.

*Dimension IL is shown in the General Motors Light-Duty Truck Facts/Data Book.

TRUCK – CAMPER LOADING 1988 C/K MODELS

Loading Instructions—When the truck is used to carry a slide-in camper, the total cargo load of the truck consists of the manufacturer's camper weight figure, the weight of installed additional camper equipment not included in the manufacturer's camper weight figure, the weight of camper cargo and the weight of passengers *in the camper*. The total cargo load should not exceed the truck's cargo weight rating (CWR) and the camper's center of gravity should fall within the truck's recommended center of gravity zone when installed.

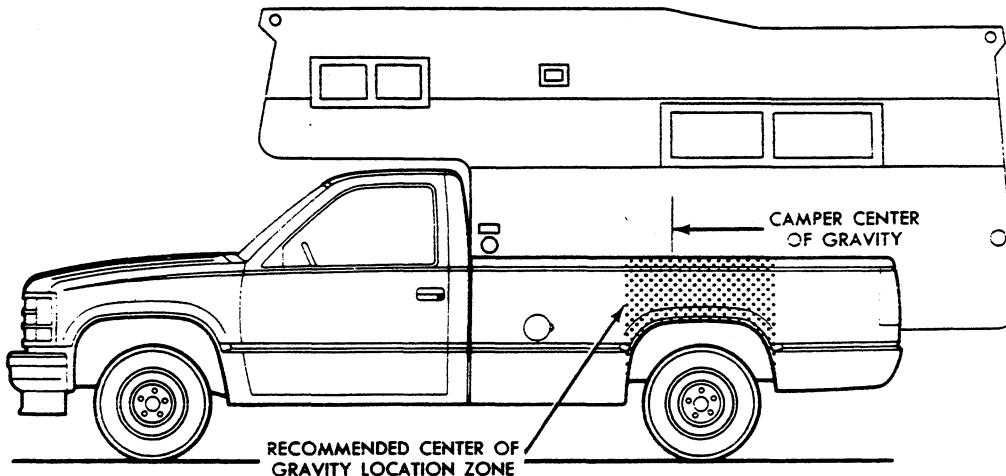

Any accessories or other equipment added to this vehicle, after final date of manufacture, must be weighed or have their weight determined, and the weight deducted from the prescribed cargo weight rating (CWR) of this vehicle. This may decrease the permissible longitudinal zone of the center of gravity for this vehicle.

The longitudinal center of gravity zone has been determined for the full cargo weight rating of this truck. If a slide-in camper has a total weight less than the cargo weight rating (CWR), the permissible longitudinal zone of the center of gravity may be larger. However, individual axle loads should not exceed either of the gross axle weight ratings (GAWR).

Secure loose items to prevent weight shifts that could affect the balance of your vehicle. When the truck camper is loaded, drive to a scale and weigh the front and the rear separately to determine the axle loads. Individual axle loads should not exceed either of the gross axle weight ratings (GAWR). The total of the axle loads should not exceed the gross vehicle weight rating (GVWR). These ratings are given on the vehicle identification plate and on the vehicle certification label which are located on the left side of the vehicle, normally on the door latch post or door edge next to the driver. If weight ratings are exceeded, move or remove items to bring all weights below the ratings.

CAUTION: The longitudinal center of gravity is only one of the many factors which may affect the overall performance of a vehicle, including handling, steering and braking. The recommended, longitudinal limits for the camper's center of gravity are based on the assumption that the vehicle will be operated with reasonable prudence in light of all of the existing conditions. Failure to do so could result in unsatisfactory vehicle performance and could make the vehicle unsafe to operate.

In this connection, refer to any recommendations by the slide-in camper manufacturer regarding installation and loading of the camper.

TRUCK-CAMPER LOADING
1988 C/K MODELS
DEFINITION OF TERMS

For the purposes of calculating Truck-Camper Loading in this book, listed below are some common terms and abbreviations:

Cargo Weight Rating (CWR)—means the value specified by the vehicle manufacturer as the cargo-carrying capacity, in pounds, of a vehicle, exclusive of (minus) the weight of occupants, computed as 150 pounds times the number of designated seating positions.

Center of Gravity (CG)—Point where the mass of a body is concentrated and if suspended at that point would balance front and rear.

Curb Weight—Weight of a vehicle without driver, passengers or cargo but including fuel, coolant and other items of standard equipment.

Dimension A & B—Center of Gravity (CG) zone.

Gross Vehicle Weight Rating or "GVWR" means the value specified by the manufacturer as the loaded weight of a single vehicle.

Gross Axle Weight Rating or "GAWR" means the value specified by the vehicle manufacturer as the load carrying capacity of a single axle system measured at the tire-ground interfaces.

Model Weight—Weight of the vehicle with all items of standard equipment, 150 pounds per passenger in each designated seating position and maximum capacity of fuel, oil and coolant.

Payload Rating—is the maximum allowable load (including the weight of the driver and all occupants) that the vehicle can carry based on all factory-installed equipment on the vehicle.

Slide-in Camper—means a camper having a roof, floor, and sides, designed to be mounted on and removable from the cargo area of a truck by the user.

Weight Distribution—The amount of a vehicle's weight that rests on each axle.

Wheelbase (WB)—The distance from the center line of the front axle to the center line of the rear axle.

LIMITATIONS

- C/K1500 Pickups should not be used for large cab-over-type slide-in campers.
- Any pickup model with a cargo weight rating (CWR) of less than 500 lbs.

A statement is imprinted on the Truck-Camper Loading information label which states that the vehicle should not be used to carry a slide-in camper.

TRUCK – CAMPER LOADING

1988 C/K MODELS

INSTRUCTIONS

VEHICLE SELECTION AND WEIGHT ANALYSIS

1. From the model selector in the 1988 C/K Pickup section of the General Motors Light-Duty Truck Facts/Data Book, select the pickup truck model you desire. Record this information on page 3. Refer to the GVWR selector for the selected model. Select the GVWR you require and note the minimum tire size and chassis equipment required for that GVWR. To approximate the GVWR you require, add your loaded camper weight to the vehicle model weight shown on the appropriate model weight and dimension page of the Facts/Data Book. Record this information and the Gross Axle Weight Rating (GAWR), Front and Rear, on the C/K Pickup camper loading worksheet, page 7.
2. Record the front and rear model weights of your selected vehicle.
3. In the appropriate sections of the worksheet, record the tires you desire. Keep in mind that you must select suspension equipment having load capacities equal to or greater than those of the minimum equipment required for your selected GVWR. Record the front and rear weight and the load capacity of the tires in the appropriate columns.
4. List all other factory-installed options you desire with their front and rear weights on the C/K Pickup camper loading worksheet.
5. Total the front and rear weights of vehicle model and options to arrive at the total front and rear weight of the vehicle. •
6. Subtract the total front and rear weights of the vehicle from the GVWR to arrive at the cargo weight rating (CWR) of your truck ■. Record this information on page 3.
7. Proceed to page 9 and calculate the center of gravity location limits using front and rear GAWRs, cargo weight rating (CWR), and front and rear weight of truck as determined above. Record this information on page 3.
 - If your vehicle is available, drive to a scale and weigh on the front and on the rear wheels separately to determine the axle loads. You will then be able to use your actual cargo weight rating and not have to add the 50# for all models.
 - The addition of any dealer-installed or other accessories will reduce the cargo carrying capacity by the weight of the equipment installed.

**TRUCK – CAMPER LOADING
1988 C/K PICKUPS
WORKSHEET – CARGO WEIGHT RATING**

1. **Model GVWR** _____ **GAWR FRONT** _____ **REAR** _____

2. **Model Weights:** _____ **FRONT** _____ **REAR** _____

3. **Chassis Equipment selected to meet GVWR requirements:**

Load Capacity*

Tires: Front () _____

Rear () _____

4. **Other factory-installed options:**

.....

.....

.....

.....

.....

.....

.....

.....

.....

.....

TOTALS _____

5. **Front and Rear Weight:** _____

5a. **Vehicle sub-total weight** (add front and rear weight): _____

5b. **Add 50 lbs for all models*** _____ +50

5c. **Adjusted total vehicle weight:** _____

6. **Vehicle GVWR:** _____

Adjusted total vehicle weight _____

Cargo Weight Rating _____

Record on page 3.

*Load capacity is the rating in pounds for each tire
*If your vehicle is available, drive to a scale and weigh on the front and on the rear wheels separately to determine the axle loads. You will then be able to use your actual cargo weight rating and not have to add either the 50# for all models.

TRUCK – CAMPER LOADING

MODEL CODES AND DIMENSIONS

SERIES	MODEL NUMBER	PICKUP BOX LENGTH	PICKUP STYLE	WB	"C"
--------	--------------	-------------------	--------------	----	-----

C/K REGULAR CAB MODELS

C/K1500	C/K10703	6½'	Fleetside/Wideside (E63)	117.5"	38.70"
	C/K10903	8'	Fleetside/Wideside (E63)	131.5"	43.57"
C/K2500	C/K20903	8'	Fleetside/Wideside (E63)	131.5"	43.57"
C/K3500	C/K30903	8'	Fleetside/Wideside (E63)	131.5"	43.57"

C/K EXTENDED CAB MODELS

C/K1500	C/K10953	8'	Fleetside/Wideside (E63)	155.5"	43.57"
C/K2500	C/K20953	8'	Fleetside/Wideside (E63)	155.5"	43.57"
C/K3500	C/K30953	8'	Fleetside/Wideside (E63)	155.5"	43.57"

EXTENDED CAB

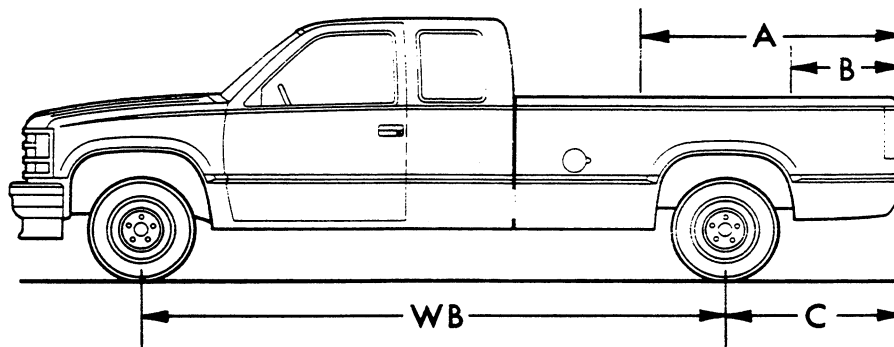

FLEETSIDE/WIDESIDE

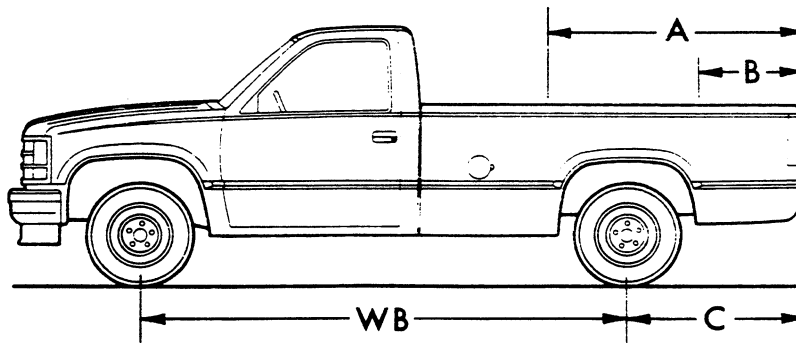

TRUCK – CAMPER LOADING

CALCULATIONS TO DETERMINE FORWARD (A) AND REARWARD (B) LOCATION OF CENTER OF GRAVITY FOR CARGO WEIGHT RATING

Calculations for Dimension A

$$A = \frac{\text{Front GAWR} - 1.05 \times \text{Front Weight of Truck}}{\text{Cargo Weight Rating}} \times \text{W.B.} + C$$

Enter Front GAWR _____

Subtract Front Weight of Truck x 1.05 (_____)

Answer _____

Divide Answer by Cargo Weight Rating (CWR) (_____)

Answer _____

Multiply Answer by Wheelbase (_____)

(See Chart on Page 8)

Answer _____

Add C Dimension to Answer -C _____

(See Chart on Page 8)

Dimension A = _____

Note: If "A" is greater than pickup box length, use box length for "A" dimension.

Calculations for Dimension B

$$B = 1 - \frac{\text{Rear GAWR} - 1.1 \times \text{Rear Weight of Truck}}{\text{Cargo Weight Rating}} \times \text{W.B.} + C$$

Enter Rear GAWR _____

Subtract Rear Weight of Truck x 1.1 (_____)

Answer _____

Divide Answer by Cargo Weight Rating (CWR) (_____)

Answer _____

Subtract Answer from 1.000 (_____)

Multiply Answer by Wheelbase (_____)

Answer _____

Add C Dimension to Answer -C _____

Dimension B = _____

Note: If "B" dimension is negative, use 0 (zero) for "B" dimension.

Record dimension A and B on page 3.

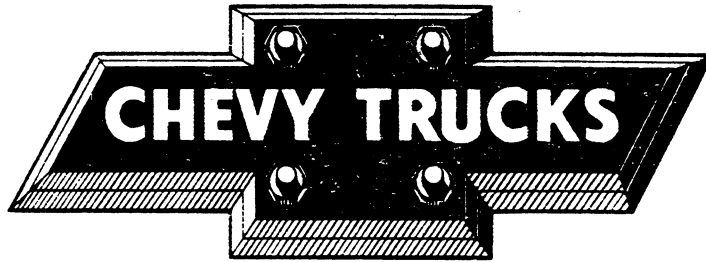

CHEVROLET MOTOR DIVISION
GENERAL MOTORS CORPORATION
WARREN, MICHIGAN 48090

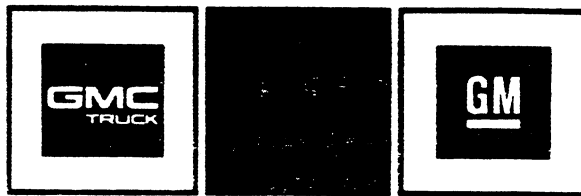

GMCTRUCK

GMC TRUCK OPERATIONS
GENERAL MOTORS CORPORATION
PONTIAC, MICHIGAN 48058

SECTION 6A4

SMALL BLOCK

The following "Notice" applies to one or more steps in the assembly procedure of components in this portion of the manual as indicated at appropriate locations by the terminology "NOTICE: See 'Notice' on page 6A4-1 of this section."

NOTICE: All engine fasteners are important attaching parts in that they could affect the performance of vital components and systems, and/or could result in major repair expense. They must be replaced with one of the same part number or with an equivalent part if replacement becomes necessary. Do not use a replacement part of lesser quality or substitute design. Torque values must be used as specified during reassembly to assure proper retention of this part.

CONTENTS

<u>SUBJECT</u>	<u>PAGE</u>
Description6A4- 2
Engine Lubrication6A4- 2
On-Vehicle Service6A4- 5
Rocker Arm Cover Replacement6A4- 5
Rocker Arm and Pushrod Replacement6A4- 5
Valve Adjustment6A4- 6
Valve Stem Seal and Valve Spring Replacement6A4- 6
Intake Manifold Replacement6A4- 7
Hydraulic Lifter Replacement6A4- 9
Rocker Arm Stud Replacement6A4- 9
Exhaust Manifold Replacement6A4-10
Cylinder Head Replacement6A4-11
Torsional Damper and Front Crankshaft Seal Replacement6A4-12
Front Cover Replacement6A4-13
Oil Pan Replacement6A4-14
Oil Pump Replacement6A4-14
Rear Crankshaft Oil Seal Replacement6A4-14
Rear Crankshaft Oil Seal Retainer Replacement6A4-15
Measuring Camshaft Lobe Lift6A4-15
Camshaft Replacement6A4-16
Connecting Rod and Piston Replacement6A4-17
Oil Filter Bypass Valve6A4-19
Main Bearing Replacement6A4-19
Crankshaft Replacement6A4-20
Flywheel Replacement6A4-20
Engine Mountings6A4-21
Engine Replacement6A4-23
Specifications6A4-25
Special Tools6A4-28

DESCRIPTION

Small block engines covered by this manual are available in two displacements; 5.0L (305 cu. in.) and 5.7L (350 cu. in.).

Small block engines are 90-degree V8 type, overhead valve, water cooled, with cast iron block and heads.

The crankshaft is supported by five precision insert main bearings, with crankshaft thrust taken at the number five (rear) bearing.

The camshaft is supported by five plain type bearings and is chain driven. Motion from the camshaft is transmitted to the valves by hydraulic lifters, pushrods, and ball type rocker arms. The valve guides are integral in the cylinder head.

The connecting rods are forged steel, with precision insert type crankpin bearings. The piston pins are a press fit in the connecting rods.

The pistons are cast aluminum alloy. The piston pins are a floating fit in the piston.

ENGINE LUBRICATION

Lubrication schematics are shown in figures 1 and 2. The gear type oil pump is driven from the distributor shaft, which is gear driven from the camshaft. Oil is drawn into the oil pump through a pickup screen and pipe.

Pressurized oil is routed to the oil filter. In case of excessive oil pressure, a bypass valve is provided. Filtered oil flows into the main gallery and then to the camshaft and crankshaft bearings. The valve lifter oil gallery supplies oil to the valve lifters. Oil flows from the hydraulic lifters through the hollow pushrods to the rocker arms. Oil from the overhead drains back to the crankcase through oil drain holes.

The timing chain is drip fed from the front camshaft bearing. The pistons and piston pins are lubricated by oil splash.

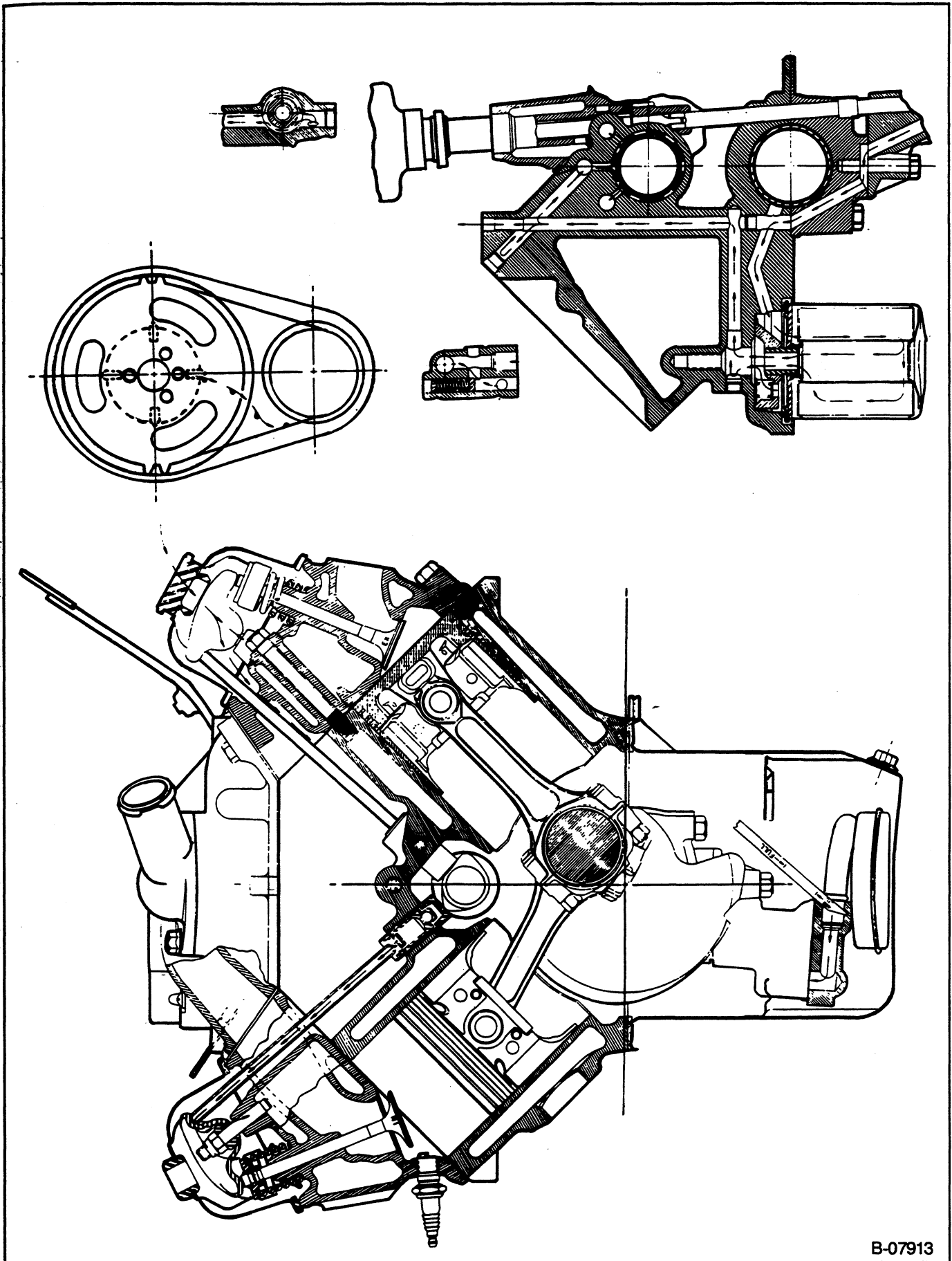

B-07913

Figure 1—Engine Lubrication Diagram

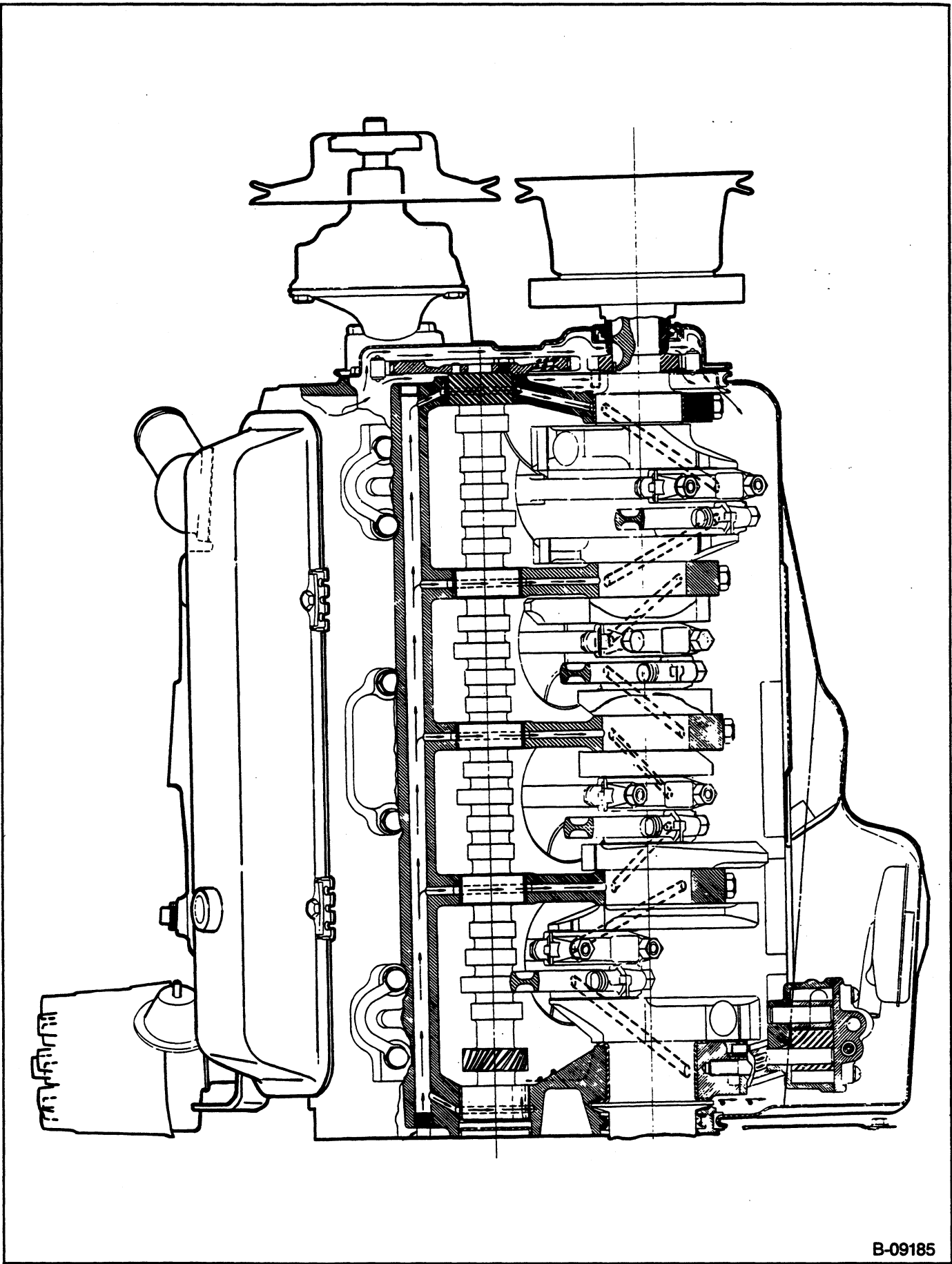

B-09185

Figure 2—Engine Lubrication Diagram

ON-VEHICLE SERVICE

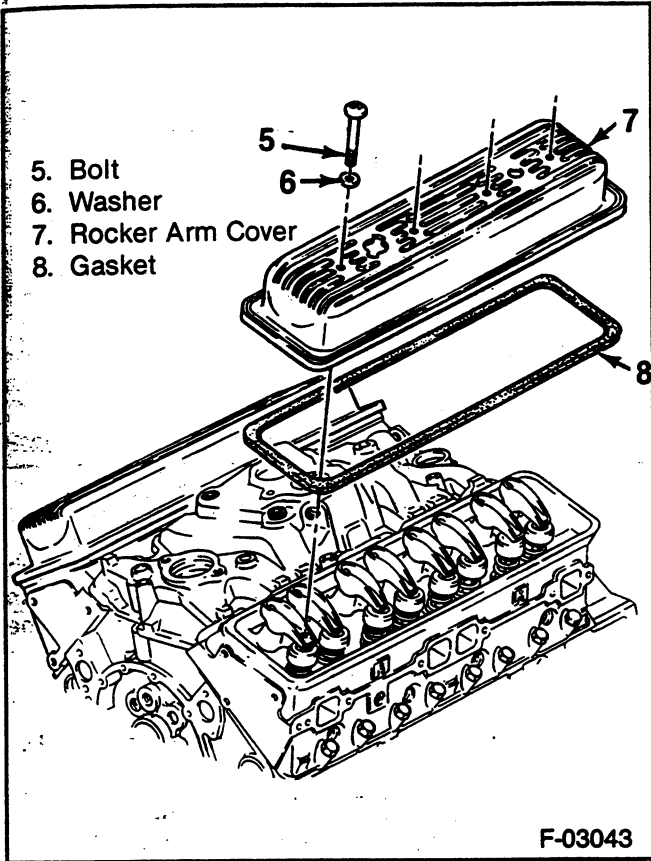

- 5. Bolt
- 6. Washer
- 7. Rocker Arm Cover
- 8. Gasket

F-03043

Figure 3—Rocker Arm Cover

ROCKER ARM COVER REPLACEMENT

↔ Remove or Disconnect (Figure 3)

1. Battery negative cable.
2. Air cleaner.
3. Crankcase ventilation hoses at the rocker arm covers.
4. Wiring harnesses from the clips, and move aside.
5. Components as follows for right rocker arm cover:
 - PCV valve.
 - Upper dipstick bracket.
 - Heat stove pipe.
 - Emissions sensors with bracket, and move aside.
6. Components as follows for left rocker arm cover.:
 - Generator rear brace.
 - Crankcase ventilation pipe.
 - Power brake vacuum pipe and move aside.
7. Rocker arm cover bolts and washers.
8. Rocker arm cover and gasket.

☑ Clean

- All traces of old gasket from the rocker arm cover and cylinder head.

👁 Inspect

- Rocker arm cover sealing surface for distortion. Replace if necessary.

↔ Install or Connect (Figure 3)

1. Rocker arm cover and new gasket.
2. Rocker arm cover bolts and washers.

🔩 Tighten

- Bolts to 11.3 N·m (100 in. lbs.).
3. Components as follows for left rocker arm cover:
 - Power brake vacuum pipe.
 - Crankcase ventilation pipe.
 - Generator rear brace.
 4. Components as follows for right rocker arm cover:
 - Emissions sensors with bracket.
 - Heat stove pipe.
 - Upper dipstick bracket.
 - PCV valve.
 5. Wiring harnesses to the rocker arm clips.
 6. Crankcase ventilation hoses.
 7. Air cleaner.
 8. Battery negative cable.

ROCKER ARM AND PUSHROD REPLACEMENT

↔ Remove or Disconnect

1. Rocker arm cover, as outlined previously.
2. Rocker arm nut.
 - If only the pushrod is to be replaced, back the rocker arm nut off until the rocker arm can be swung away from the pushrod. Then pull the pushrod out.
3. Rocker arm with ball.
4. Pushrod.

! Important

- Store used components in order so they can be reassembled in the same location.

👁 Inspect

- Rocker arms and balls at their mating surfaces. These surfaces should be smooth and free from scoring or other damage.
- Rocker arm areas which contact the valve stems and the sockets which contact the pushrods. These areas should be smooth and free of damage and wear.
- Pushrods for bending. Roll the pushrod on a flat surface to determine if it is bent. Replace if necessary.
- Ends of the pushrods for scoring or roughness.

↔ Install or Connect

1. Pushrod. Make sure the pushrod seats properly in the hydraulic lifter.
2. Rocker arm with ball.

6A4-6 SMALL BLOCK

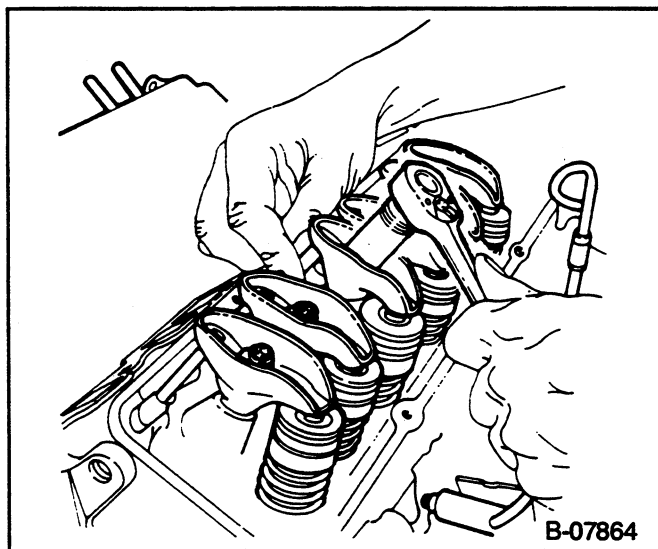

Figure 4—Adjusting the Valves



Important

- When new rocker arms and/or balls are installed, coat their bearing surfaces with “Molykote” or equivalent.

3. Rocker arm nut.



Adjust

- Valves as outlined later.

4. Rocker arm cover, as outlined previously.

VALVE ADJUSTMENT

1. Remove the rocker arm cover as outlined previously.
2. Crank the engine until the mark on the vibration damper lines up with the “O” mark on the timing tab and the engine in the number one firing position. This may be determined by placing fingers on the number one valve as the mark on the damper comes near the “O” mark on the timing tab. If the rocker arms are not moving, the engine is in the number one firing position. If the rocker arms move as the mark comes up to the timing tab, the engine is in the number six firing position and should be turned over one more time to reach the number one position.
3. With the engine in the number one firing position as determined above, the following valves may be adjusted:
 - Exhaust: 1, 3, 4, 8
 - Intake: 1, 2, 5, 7

(Even numbered cylinders are in the right bank; odd numbered cylinders are in the left bank, when viewed from the rear of the engine).

4. Back out the adjusting nut until lash is felt at the pushrod then turn in the adjusting nut until all lash is removed. This can be determined by rotating the pushrod while turning the adjusting nut (figure 4). When the play has been removed, turn the adjusting nut in one full additional turn (to center the lifter plunger).

- | | |
|------------------|-------------------|
| 20. Valve Keeper | 26. Spring |
| 21. Cap | 27. Intake Valve |
| 22. Shield | 28. Rotator |
| 23. O-Ring Seal | 29. Exhaust Valve |
| 24. Seal | |
| 25. Damper | |

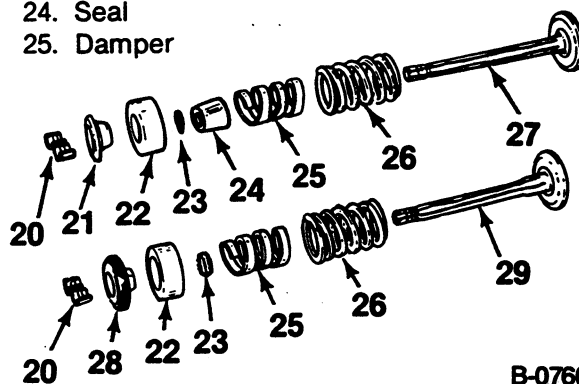

Figure 5—Valves and Components

5. Crank the engine one revolution until the timing tab “O” mark and vibration damper mark are again in alignment. This is the number six firing position the following valves may be adjusted:
 - Exhaust: 2, 5, 6, 7
 - Intake: 3, 4, 6, 8
6. Install the rocker arm cover as outlined previously.

VALVE STEM SEAL AND VALVE SPRING REPLACEMENT



Remove or Disconnect (Figures 5 and 6)

Tools Required:

J-23590 Air Adapter.

J-5892-B Spring Compressor.

1. Rocker arm cover, as outlined previously.
2. Rocker arms, as outlined previously.
3. Spark plugs.
4. Valve keepers (20).
 - Install J-23590 into the spark plug hole.

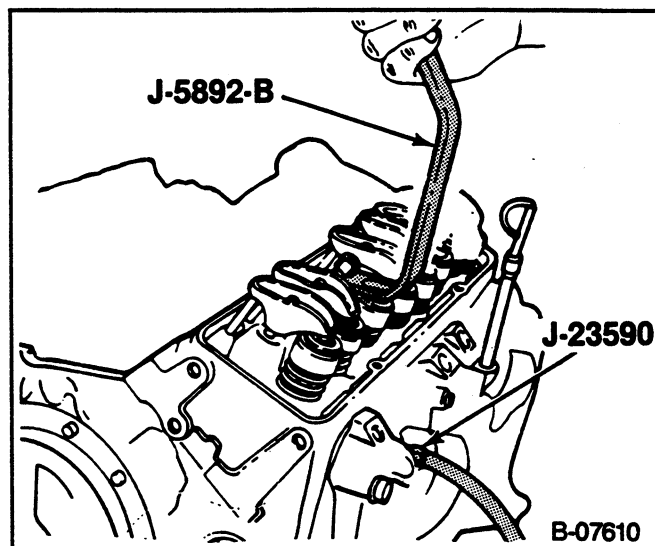
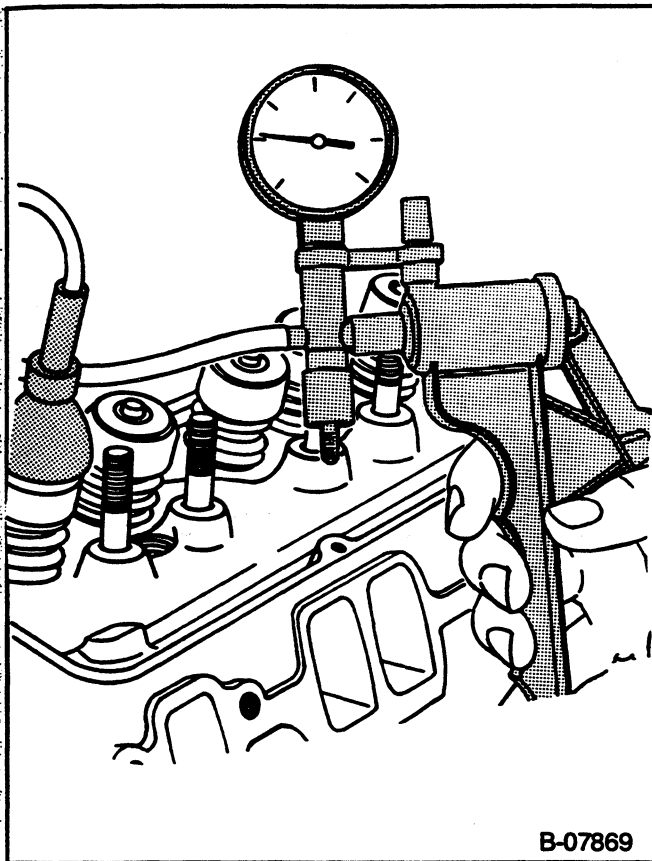

Figure 6—Compressing the Valve Springs



B-07869

Figure 7—Testing the Valve Seals

- Apply compressed air to hold the valves in place.
 - Install a rocker arm nut (figure 6).
 - Use J-5892-B to compress the valve spring (figure 6).
 - Remove the valve keepers.
 - Carefully release the spring tension. Remove J-5892-B.
5. Cap (21) and/or rotator (28), shield (22) and spring (26) with damper (25).
 6. O-ring seal (23).
 7. Seal (24) (intake valve only).

↔ Install or Connect (Figures 5, 6, and 7)

Tools Required:

- J-23590 Air Adapter
- J-5892-B Spring Compressor
- J-23738-A Vacuum Pump

1. New seal (24) (intake valve only). Install the seal over the valve stem and seat it against the head.
2. Spring (26) with damper (25), shield (22) and cap (21) and/or rotator (28).
3. New O-ring seal (23) and valve keepers (20).
 - With air pressure applied to the cylinder with J-23590, compress the spring with J-5892-B (figure 6).
 - Lubricate the O-ring seal with engine oil. Install the seal on the valve stem. Make sure the seal is not twisted.
 - Install the valve keepers. Use grease to hold them in place.

- Carefully release spring pressure. Make sure the valve keepers stay in place.
- Remove J-5892-B and J-23590.
- Check each O-ring seal for leakage (figure 7).
 - Place the suction cup furnished with J-23738-A over the shield.
 - Connect J-23738-A to the suction cup and apply a vacuum. Watch the vacuum pump gage. No air should be able to leak past the seal. If the seal will not hold a vacuum, it may have been damaged or improperly installed.

4. Spark plugs.
5. Rocker arms, as outlined previously.

🔧 Adjust

- Valves, as outlined previously.
6. Rocker arm cover, as outlined previously.

INTAKE MANIFOLD REPLACEMENT

↔ Remove or Disconnect

1. Battery negative cable.
2. Air cleaner.
 - Drain the cooling system.
3. Heater pipe and upper radiator hose at the intake manifold.
4. Generator rear brace at the manifold.
5. Vacuum hoses at the manifold, TBI unit, and EGR valve.
6. Electrical connections at the manifold and TBI unit.
7. Fuel line(s) at the TBI unit.
8. Accelerator, cruise control, and TVS cables, as equipped.
9. Distributor. Refer to ENGINE ELECTRICAL (SEC. 6D).
10. Air conditioning compressor rear bracket.
11. Brake booster vacuum pipe.
12. Coil wires.
13. Emission control sensors and bracket on right side.
14. Fuel line bracket at rear of manifold. Move the fuel lines aside.
15. Bracket at rear of belt idler.
16. TBI unit (if necessary).
17. Intake manifold bolts.
18. Intake manifold.
19. Gaskets and clips, if equipped (some TBI engines).

🧼 Clean

- Old gasket and RTV from the block, heads, and intake manifold. Remove all RTV that is loose or will cause interference at assembly.
- Excessive carbon deposits from the exhaust and EGR passages.
- Excessive scale and deposits from the coolant passages.

👁 Inspect

- Manifold for cracks and gasket surface damage.

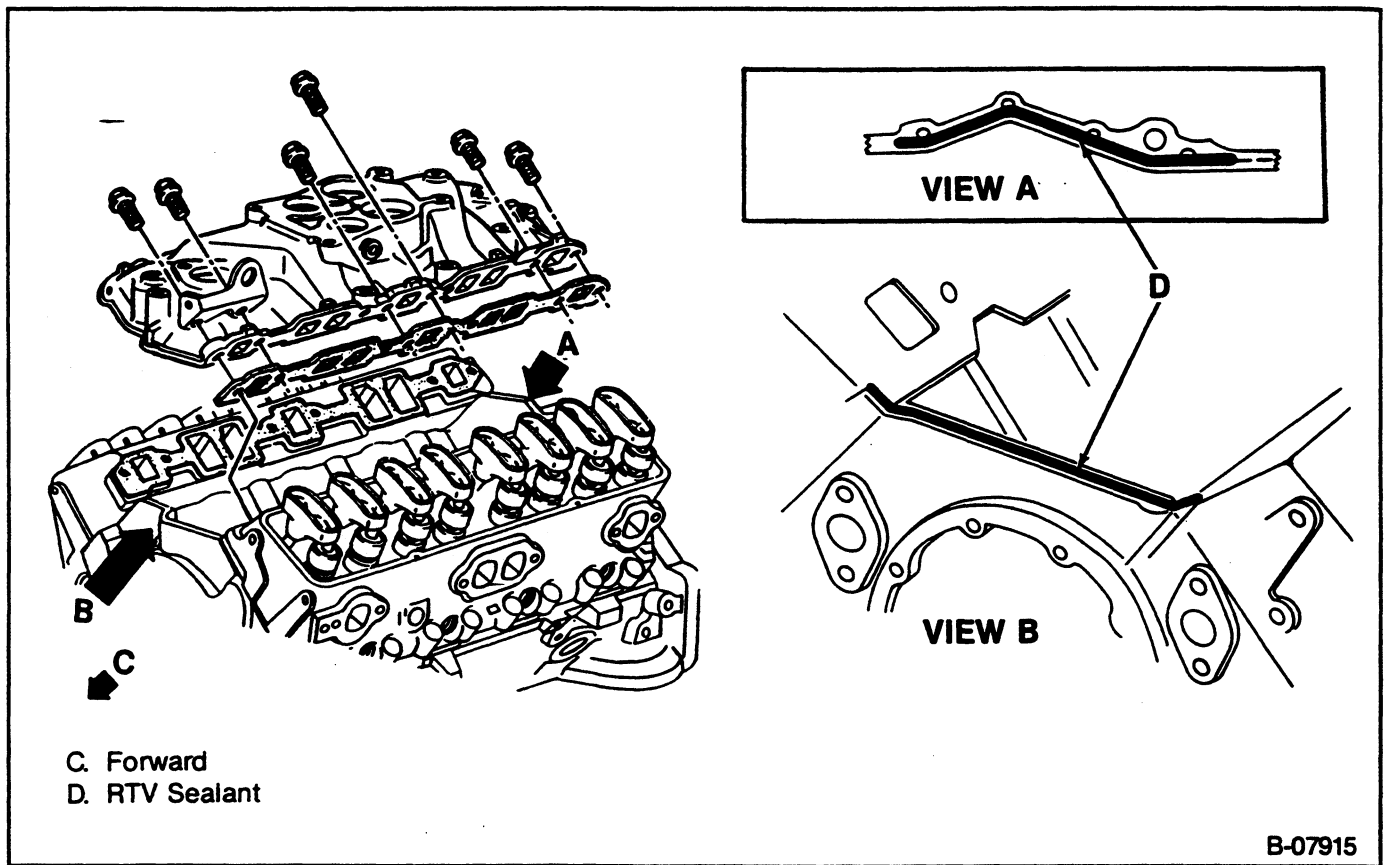

Figure 8—Intake Manifold

Install or Connect (Figures 8 and 9)

1. Gaskets to the cylinder head. On TBI engines so equipped, also install the clips over the gaskets, to the rib between the intake ports. Then apply a dot of RTV to the upper side of the clip.
2. RTV to the front and rear sealing surfaces on the block (figure 8). Apply a 5 mm (3/16-inch) bead of RTV (part number 1052366 or equivalent) to the front and rear of the block as shown. Extend the bead 13 mm (1/2-inch) up each cylinder head to seal and retain the gaskets.
3. Intake manifold to the engine.
4. Intake manifold bolts.

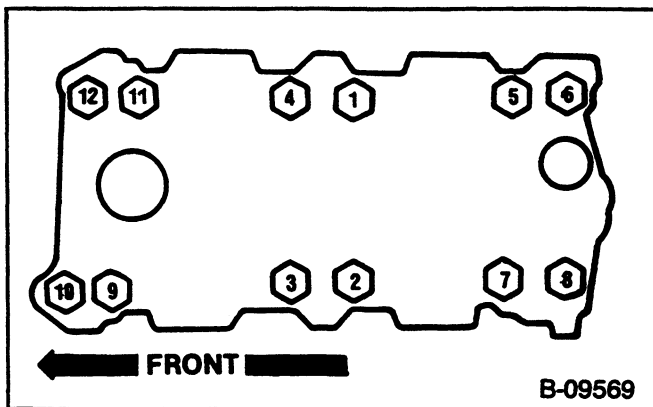

Figure 9—Intake Manifold Bolt Tightening Sequence

Tighten

- Intake manifold bolts to 48 N-m (35 ft. lbs.). Use the tightening sequence shown in figure 9.
5. TBI unit (if removed).
 6. Bracket at rear of belt idler.
 7. Fuel line bracket at rear of manifold.
 8. Emission control sensors and bracket.
 9. Coil wires.
 10. Brake booster vacuum pipe.
 11. Air conditioning compressor rear bracket.
 12. Distributor. Refer to ENGINE ELECTRICAL (SEC. 6D).
 13. Accelerator, cruise control, and TVS cables, as equipped.
 14. Fuel line(s) at the TBI unit.
 15. Electrical connections.
 16. Vacuum hoses.
 17. Generator brace.
 18. Heater pipe and upper radiator hose.
 19. Air cleaner.
 20. Battery negative cable.
- Fill the cooling system with the proper quantity and grade of coolant.

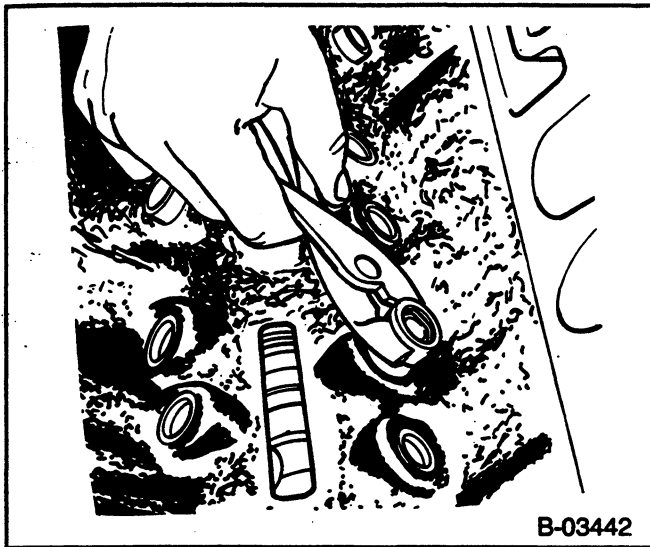

Figure 10—Removing the Hydraulic Lifter

HYDRAULIC LIFTER REPLACEMENT

Remove or Disconnect (Figures 10 and 11)

Tools Required:

- J-3049 Hydraulic Lifter Remover (Plier Type) or
- J-9290-01 Hydraulic Lifter Remover (Slide Hammer Type)

1. Rocker arm cover, intake manifold, and pushrod, as outlined previously.
2. Hydraulic lifters.
 - Remove the hydraulic lifters one at a time and place them in an organizer rack. The lifters must be installed in the same bore from which they were removed.
 - A stuck hydraulic lifter can be removed using J-3049 (figure 10) or J-9290-01 (figure 11).

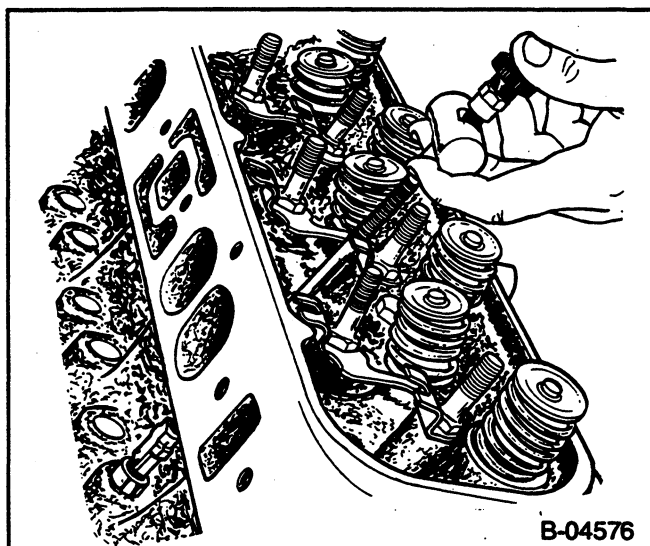
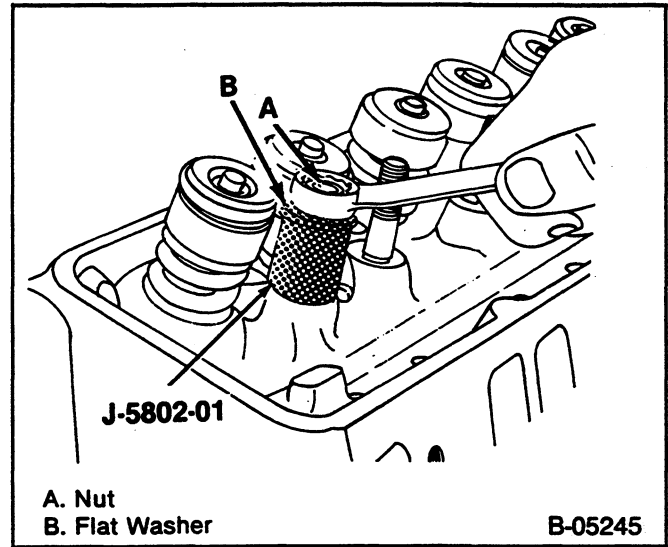

Figure 11—Removing the Hydraulic Lifter (Typical)



A. Nut
B. Flat Washer

B-05245

Figure 12—Removing the Rocker Arm Stud

Inspect

- Hydraulic lifter body for scuffing and scoring. If the lifter body wall is worn or damaged, the mating bore in the block should also be checked.
- Check the fit of each hydraulic lifter in its mating bore in the block. If the clearance is excessive, try a new lifter.
- The hydraulic lifter foot must be smooth and slightly convex. If worn, pitted, or damaged, the mating camshaft lobe should also be checked.

Hydraulic Lifter Repair

- Refer to the proper unit repair manual.

Install or Connect

1. Hydraulic lifters to the block. Lubricate the lifter foot and body with Engine Oil Supplement or equivalent.

Important

- When any new hydraulic lifters or a new camshaft is installed, change the engine oil and filter. Engine Oil Supplement (or equivalent) should be added to the crankcase oil.
- Replace all hydraulic lifters when a new camshaft is installed.

2. Intake Manifold, as outlined previously.
3. Pushrod, as outlined previously.

Adjust

- Valves, as outlined previously.
4. Rocker arm cover, as outlined previously.

ROCKER ARM STUD REPLACEMENT

Remove or Disconnect (Figure 12)

Tool Required:

- J-5802-01 Rocker Arm Stud Remover

1. Rocker arm cover and rocker arm, as outlined previously.

6A4-10 SMALL BLOCK

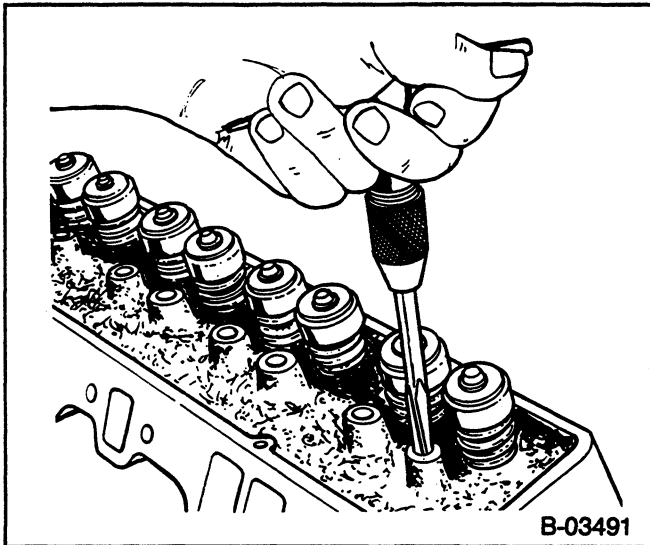

Figure 13—Reaming the Rocker Arm Stud Bore (Typical)

2. Rocker arm stud.
 - Place J-5802-01 over the rocker arm stud.
 - Install a nut and flat washer.
 - Turn the nut to remove the stud (figure 12).

Install or Connect (Figures 13 and 14)

Tools Required:

- J-5715 Reamer (0.003-inch oversize) or J-6036 Reamer (0.013-inch oversize)
- J-6880 Rocker Arm Stud Installer

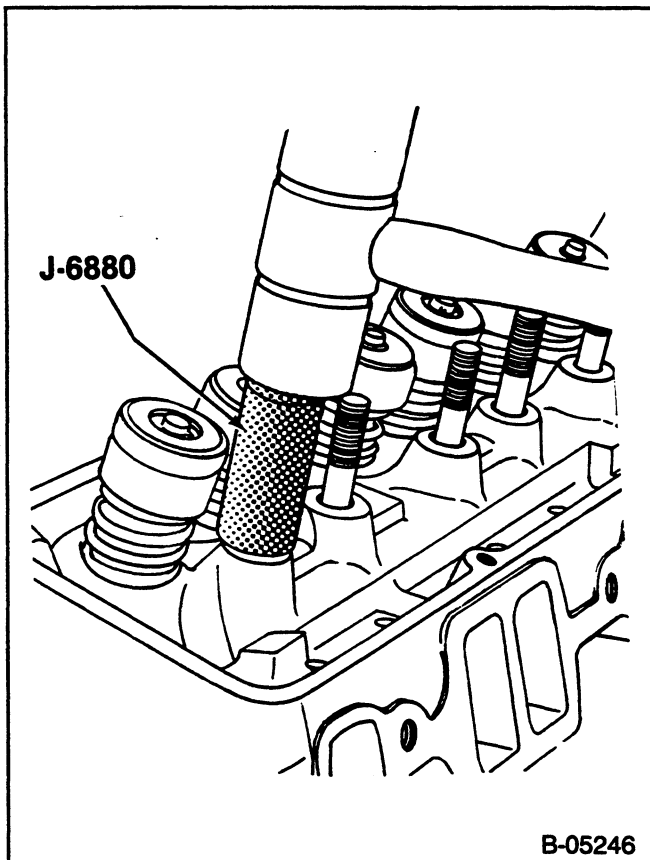

Figure 14—Installing the Rocker Arm Stud

NOTICE: Do not attempt to install an oversize rocker arm stud without reaming stud hole as this could damage the cylinder head.

- Ream the hole to the proper size for the replacement oversize rocker arm stud. Use J-5715 for 0.003-inch oversize studs; J-6036 for 0.013-inch oversize studs (figure 13).
 - Coat lower end (press-fit area) of rocker arm stud with hypoid axle lubricant.
1. Rocker arm stud. Use J-6880 (figure 14). Stud is installed to proper depth when the tool bottoms on the cylinder head.
 2. Rocker arm, as outlined previously.

Adjust

- Valves, as outlined previously.
3. Rocker arm cover, as outlined previously.

EXHAUST MANIFOLD REPLACEMENT

Remove or Disconnect

1. Battery negative cable.
 - Raise the vehicle. Support with suitable safety stands.
2. Exhaust pipe at the manifold.
 - Lower the vehicle.
3. Oxygen sensor wire (left side manifold). Do not remove the oxygen sensor unless replacement is required.
4. AIR hose at the check valve.
5. Heat stove pipe (right side manifold).
6. Power steering pump rear bracket at the manifold (left side manifold).
7. Dipstick tube bracket (right side manifold).
8. Exhaust manifold bolts, washers, and tab washers.
9. Exhaust manifold.

Clean

- Mating surfaces on the manifold and head.
- Threads on the exhaust manifold bolts.

Install or Connect

1. Exhaust manifold to the cylinder head.
2. Exhaust manifold fasteners. Install the flat washers against the manifold, then the tab washers and bolts.

Tighten

- Two center bolts to 36 N·m (26 ft. lbs.).
 - Outside bolts to 28 N·m (20 ft. lbs.).
 - Bend the tab washers against the bolt heads.
3. Power steering pump rear bracket at the manifold (left side manifold).
 4. Dipstick tube bracket (right side manifold).
 5. Heat stove pipe (right side manifold).
 6. AIR hose at the check valve.
 7. Oxygen sensor wire.
 - Raise the vehicle. Support with suitable safety stands.
 8. Exhaust pipe.

- Lower the vehicle.
- 9. Battery negative cable.

CYLINDER HEAD REPLACEMENT

Remove or Disconnect

1. Battery negative cable.
 - Drain the cooling system.
2. Intake manifold, as outlined previously.
3. Exhaust manifold, as outlined previously.
4. Ground strap at rear of cylinder head (right side cylinder head).
5. AIR pipe at the rear of the cylinder head.
6. Components as follows for right side cylinder head.
 - AIR pump bolt and spacer at the cylinder head.
 - Nut and stud attaching air conditioning compressor to cylinder head.
 - Fuel pipe, plug wire and wiring harness brackets at the rear of the cylinder head.
7. Components as follows for left side cylinder head.
 - Nut and stud attaching main accessory bracket to the cylinder head. It may be necessary to loosen the remaining bolts and studs and move the bracket forward slightly for clearance to remove the cylinder head.
 - Coolant sensor wire.
 - Spark plug wire brackets at the rear of the cylinder head.
8. Rocker arm cover, as outlined previously.
9. Spark plugs.
10. Pushrods, as outlined previously.
11. Cylinder head bolts.
12. Cylinder head.
13. Head gasket.

Clean

- Carbon deposits from combustion chambers.
- All traces of old head gasket from cylinder head and block.
- Cylinder head bolt threads and threads in the block.

Inspect

- Sealing surfaces of the block and cylinder head for nicks, heavy scratches, or other damage.

Cylinder Head Repair

- Refer to the proper Unit Repair Manual.

Install or Connect (Figure 15)

1. Head gasket.
 - If a steel gasket is used, coat both sides of the gasket with sealer. Spread the sealer thin and even.
 - Do not use sealer on composition steel-asbestos gaskets.
 - Place the gasket over the block dowel pins with the bead up.
2. Cylinder head. Carefully guide the cylinder head into place over the dowel pins and gasket.

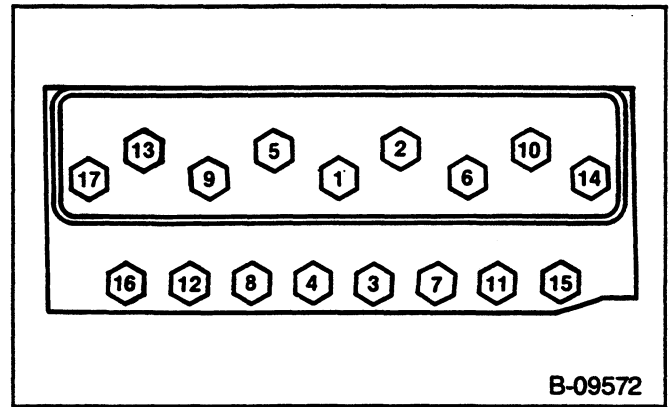

B-09572

Figure 15—Cylinder Head Bolt Tightening Sequence

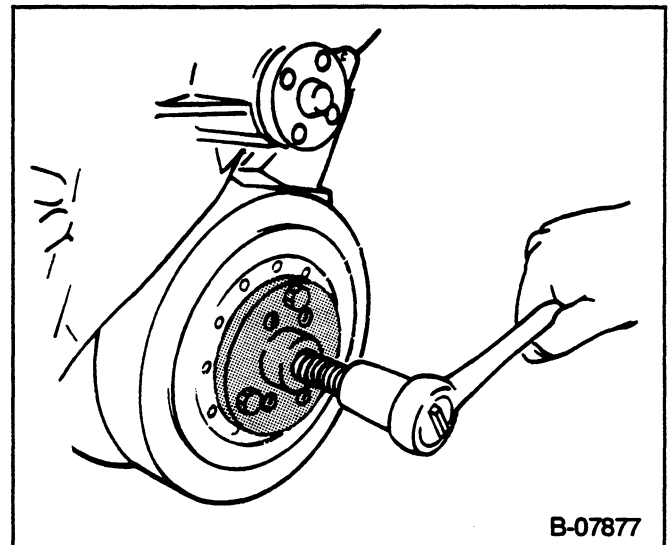

B-07877

Figure 16—Removing the Torsional Damper

3. Cylinder head bolts. Coat threads of the cylinder head bolts with sealing compound (GM part number 1052080 or equivalent) and install finger-tight.

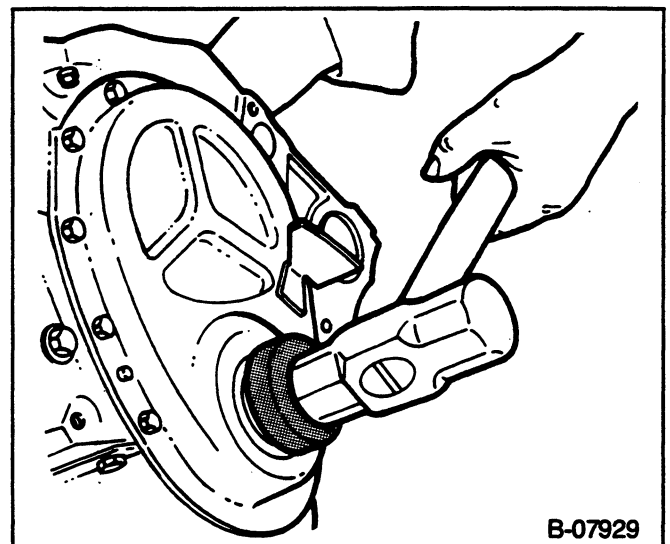

B-07929

Figure 17—Installing the Front Crankshaft Oil Seal

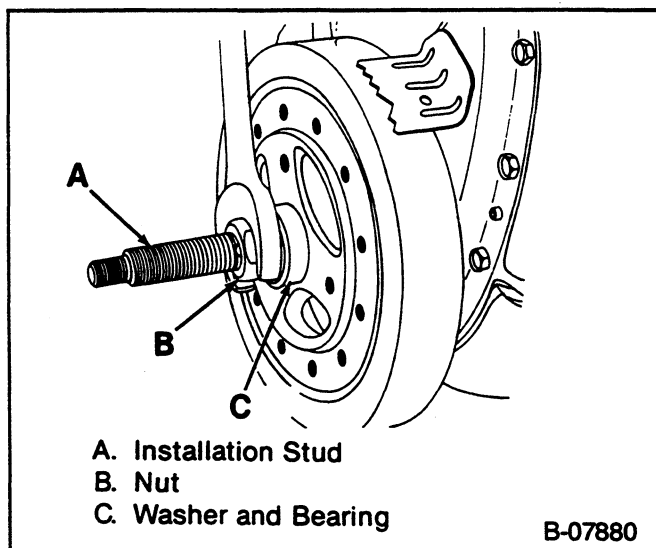

Figure 18—Installing the Torsional Damper

Tighten

- Cylinder head bolts, a little at a time, using the sequence shown in figure 15. Proper torque is 90 N·m (65 ft. lbs.).

4. Pushrods, as outlined previously.

Adjust

- Valves, as outlined previously.

5. Rocker arm cover, as outlined previously.

6. Spark plugs.

7. Components as follows for right side cylinder head:

- AIR pump bolt and spacer at the cylinder head.
- Nut and stud attaching the air conditioning compressor to the cylinder head.
- Fuel pipe, plug wire and wiring harness brackets at the rear of the cylinder head.

8. Components as follows for left side cylinder head:

- Nut and stud attaching main accessory bracket to the cylinder head.
- Remaining main accessory bracket bolts and nuts, if necessary.
- Coolant sensor wire.
- Spark plug wire brackets at the rear of the cylinder head.

9. AIR pipe.

10. Ground strap at the rear of the cylinder head (right side cylinder head).

11. Exhaust manifold, as outlined previously.

12. Intake manifold, as outlined previously.

13. Battery negative cable.

- Fill the cooling system with the proper quantity and grade of coolant.

TORSIONAL DAMPER AND FRONT CRANKSHAFT SEAL REPLACEMENT

Remove or Disconnect (Figure 16)

Tool Required:

J-23523-E Torsional Damper Puller and Installer

1. Fan belt, fan, and pulley.
2. Fan shroud assembly.
3. Accessory drive pulley.
4. Torsional damper bolt.
5. Torsional damper. Use J-23523-E (figure 16).
6. Front crankshaft seal. Pry out with a large screwdriver. Take care not to distort the timing cover.
7. Crankshaft key, if necessary.

Inspect

- Oil seal contact area on the torsional damper shaft for grooving and roughness. Replace if necessary.

Install or Connect (Figures 17 and 18)

Tools Required:

J-35468 Seal Installer

J-23523-E Torsional Damper Puller and Installer

1. Crankshaft key, if removed.
2. Front crankshaft seal. Use J-35468 (figure 17). The open end of the seal faces inside the engine. Coat the seal lips with engine oil.

NOTICE: The inertia weight section of the torsional damper is assembled to the hub with a rubber type material. The correct installation procedures (with the proper tool) must be followed or movement of the inertia weight section of the hub will destroy the tuning of the torsional damper.

3. Stud (item A, figure 18) to the crankshaft. Thread the stud fully into the tapped hole in the crankshaft.

4. Torsional damper over the end of the stud. Align the keyway in the torsional damper shaft with the crankshaft key.

5. Bearing, washer and nut (figure 18).

- Turn the nut to pull the vibration damper into place.
- Remove the tool.

• Use a small amount of RTV sealant to seal the torsional damper key to crankshaft joint.

6. Torsional damper bolt and washer.

Tighten

- Bolt to 95 N·m (70 ft. lbs.).

7. Accessory drive pulley.

8. Fan shroud assembly.

9. Fan pulley, fan, and fan belt.

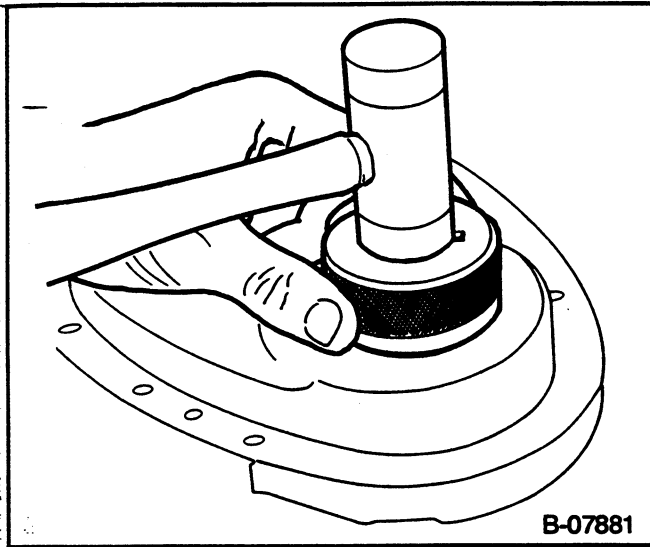

Figure 19—Installing the Front Crankshaft Oil Seal

FRONT COVER REPLACEMENT

↔ Remove or Disconnect

1. Torsional damper, as outlined previously.
2. Water pump.
3. Oil pan, as outlined later.
4. Front cover bolts.
5. Front cover.
6. Front cover to block gasket.
7. Front crankshaft seal from the front cover. Pry out with a screwdriver. Take care not to distort the front cover.

🧼 Clean

- Old gasket from the front cover and block.

🔍 Inspect

- Front cover for distortion and damage. Replace if necessary.

↔ Install or Connect (Figure 19)

Tools Required:

J-35468 Seal Installer

1. Front crankshaft seal. Use J-35468 (figure 19). The open end of the seal faces inside the engine. Coat the seal lips with engine oil.
2. Front cover gasket to the front cover. Use gasket cement to hold it in place.
3. Front cover to the engine.

🔧 Tighten

- Front cover to block bolts to 11.3 N·m (100 in. lbs.).
4. Oil pan, as outlined later.
 5. Water pump. Refer to ENGINE COOLING (SEC. 6B1).
 6. Torsional damper, as outlined previously.

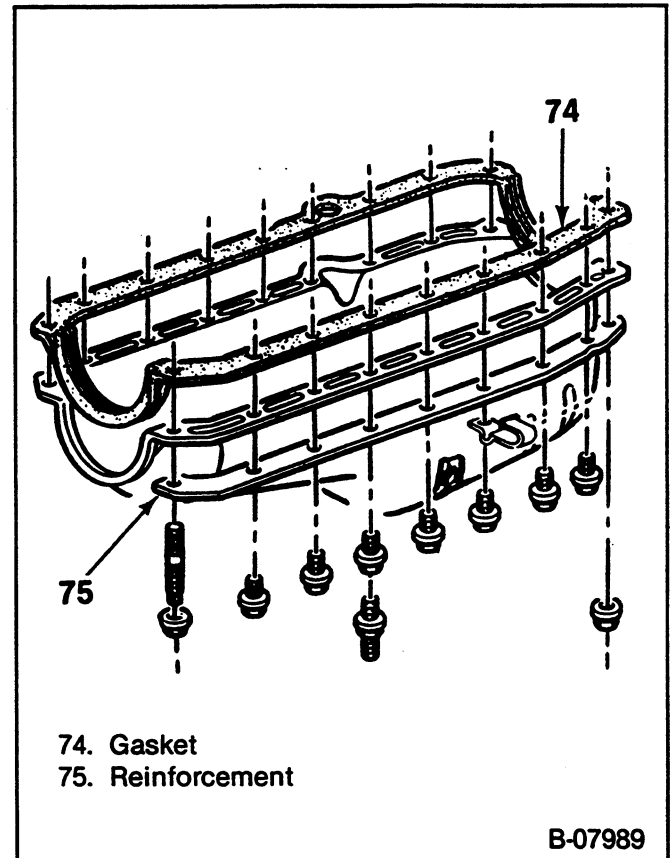

Figure 20—Oil Pan

OIL PAN REPLACEMENT

A one piece type oil pan gasket is used.

↔ Remove or Disconnect (Figure 20)

1. Battery negative cable.
- Raise the vehicle. Support with suitable safety stands.
- Drain the engine oil.
2. Exhaust crossover pipe.
3. Flywheel/torque converter cover.
4. Strut rods at the engine mountings (if used).
5. Oil pan bolts, nuts, and reinforcements.
6. Oil pan and gasket.

🧼 Clean

- Gasket surfaces on the engine and oil pan.

🔍 Inspect

- Oil pan gasket for damage. Replace if necessary.

↔ Install or Connect (Figure 20)

- Apply sealant (GM part number 1052080 or equivalent) to the front cover to block joint and to the rear crankshaft seal to block joint. Apply the sealant for about 25 mm (1 inch) in both directions from each of the four corners.
1. Oil pan gasket to the oil pan.
 2. Oil pan to the engine.
 3. Oil pan bolts, nuts, and reinforcements.

6A4-14 SMALL BLOCK



Tighten

- Oil pan bolts to 11.3 N·m (100 in. lbs.).
 - Oil pan nuts to 22.6 N·m (200 in. lbs.).
4. Strut rods at the engine mount (if used).
 5. Flywheel/torque converter cover.
 6. Exhaust crossover pipe.
 - Lower the vehicle.
 7. Proper quantity and grade of engine oil.
 8. Battery negative cable.

OIL PUMP REPLACEMENT



Remove or Disconnect

1. Oil pan, as outlined previously.
2. Oil pump bolt.
3. Oil pump.



Inspect

- Oil pump pickup tube for looseness. If the tube is loose in the oil pump body, replace it, as outlined in the proper unit repair manual. A loose pickup tube can result in an air leak and loss of oil pressure.

Oil Pump Repair

- Refer to the proper unit repair manual.



Install or Connect

1. Oil pump to the engine. Align the slot in the oil pump shaft with the tang on the distributor shaft. The oil pump should slide easily into place. No gasket is used.
2. Oil pump bolt.



Tighten

- Bolt to 90 N·m (65 ft. lbs.).
4. Oil pan, as outlined previously.

REAR CRANKSHAFT OIL SEAL REPLACEMENT



Remove or Disconnect (Figure 21)

1. Transmission.
2. Clutch and flywheel or flexplate, as equipped.

NOTICE: Care should be taken when removing the rear crankshaft oil seal so as not to nick the crankshaft sealing surface.

3. Rear crankshaft oil seal. Insert a screwdriver into the notches provided in the seal retainer and pry the seal out (figure 21). Take care not to damage the crankshaft seal surface.



Inspect

- Chamfer on crankshaft for grit, loose rust, and burrs. Correct as necessary.



Clean

- Seal running surface on the crankshaft with a non-abrasive cleaner.

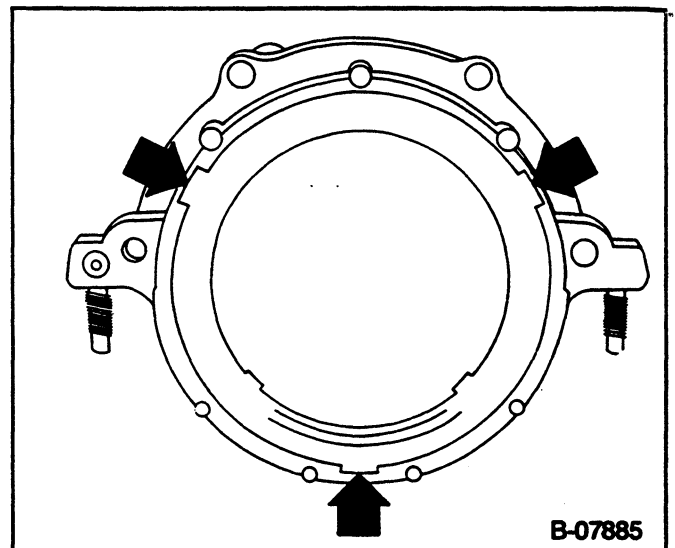

Figure 21—Seal Removal Notches



Install or Connect (Figure 22)

Tool Required:

J-35621 Seal Installer

1. Rear crankshaft oil seal (figure 22).
 - Lubricate the inner and outer diameter of the seal with engine oil.
 - Install the seal on J-35621.
 - Position J-35621 against the crankshaft. Thread the attaching screws into the tapped holes in the crankshaft.
 - Tighten the screws securely with a screwdriver. This will ensure that the seal is installed squarely over the crankshaft.
 - Turn the handle until it bottoms.
 - Remove J-35621.
2. Clutch and flywheel or flexplate, as equipped.
3. Transmission.

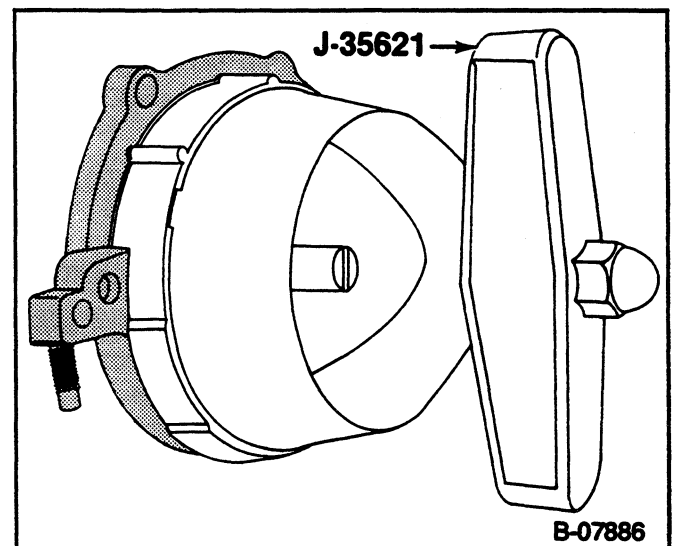

Figure 22—Installing the Rear Crankshaft Oil Seal

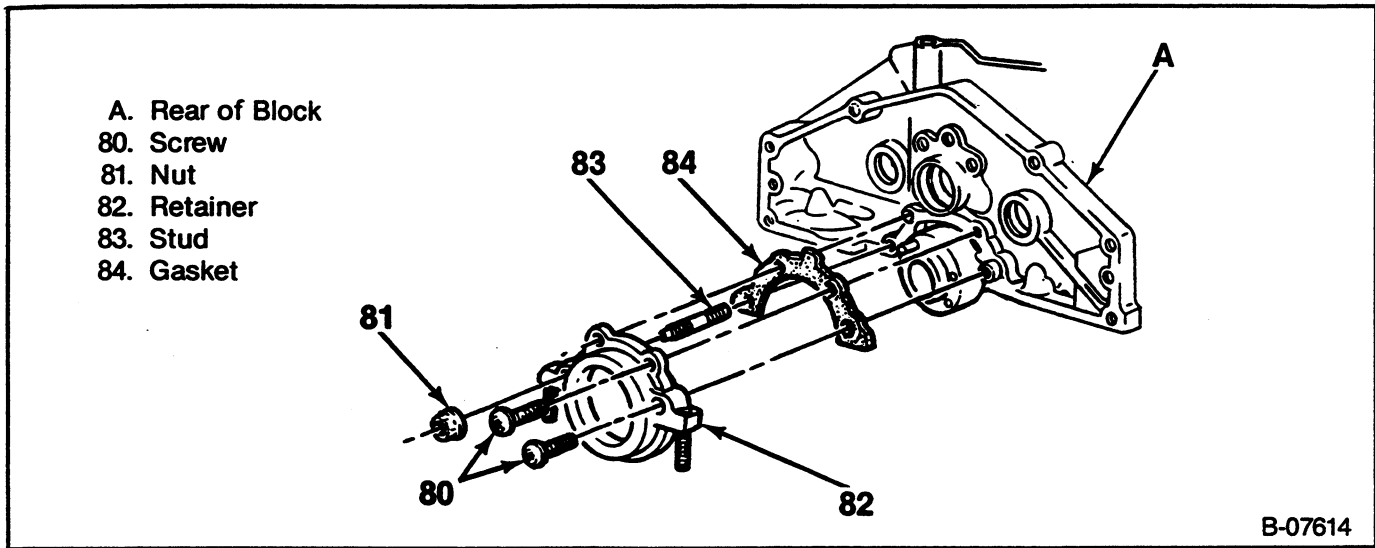

Figure 23—Rear Crankshaft Oil Seal Retainer

REAR CRANKSHAFT OIL SEAL RETAINER REPLACEMENT

↔ Remove or Disconnect (Figures 21 and 23).

1. Transmission.
2. Clutch and flywheel or flexplate, as equipped.
3. Oil pan, as outlined previously.
4. Screws (80) and nuts (81).
5. Seal retainer (82).
6. Gasket (84).
7. Rear crankshaft oil seal. Insert a screwdriver into the notches provided in the seal retainer and pry the seal out (figure 21).

☑ Clean

- Gasket surfaces on block and seal retainer.

↔ Install or Connect (Figure 23)

- Whenever the seal retainer is removed, a new retainer gasket and rear crankshaft oil seal must be installed.
1. Gasket (84) to the block. It is not necessary to use sealant to hold the gasket in place.
 2. Seal retainer (82).
 3. Screws (80) and nuts (81).

⌚ Tighten

- Screws (80) and nuts (81) to 15.3 N·m (135 in. lbs.).
4. Oil pan, as outlined previously.
 5. Rear crankshaft oil seal as outlined previously.
 6. Clutch and flywheel or flexplate, as equipped.
 7. Transmission.

MEASURING CAMSHAFT LOBE LIFT

Tool Required:

J-8520 Camshaft Lobe Lift Indicator

1. Remove the rocker arm as outlined previously.
2. Refer to figure 24. Position the dial indicator (part of J-8520) so the plunger rests on the pushrod end, as shown. Make sure the pushrod is in the lifter socket.
3. Rotate the crankshaft slowly in the direction of normal rotation until the lifter is on the heel of the cam lobe. At this point, the pushrod will be in its lowest position.
4. Set dial indicator on zero, then rotate the crankshaft slowly, or attach an auxiliary starter switch and “bump” the engine over, until the pushrod is in fully raised position.

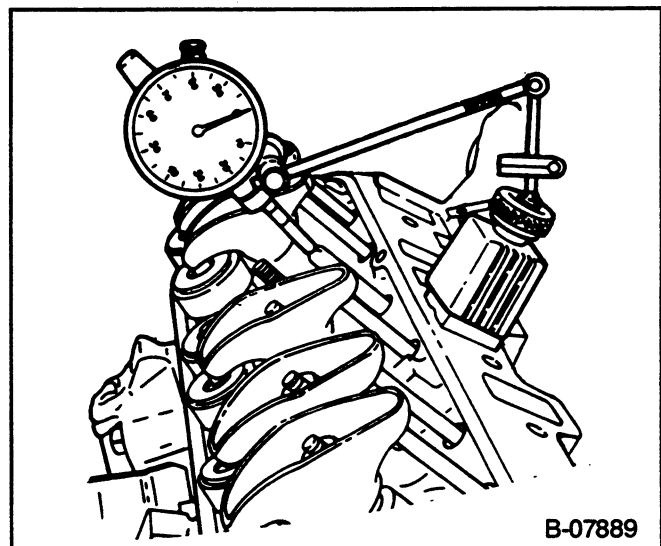
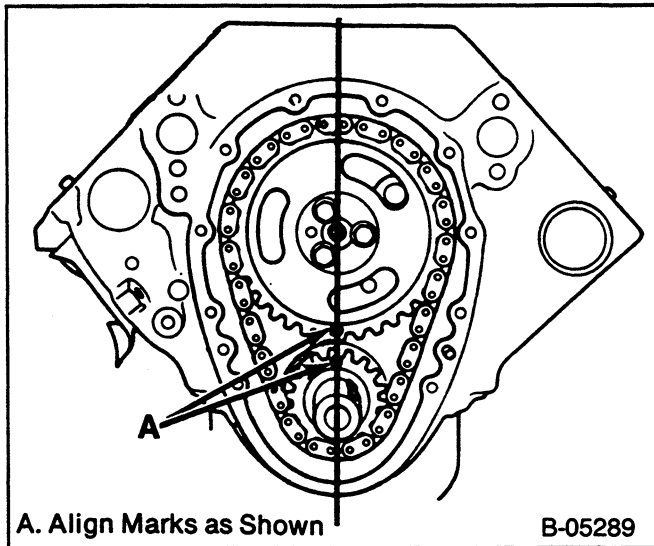

Figure 24—Measuring Camshaft Lobe Lift



A. Align Marks as Shown

B-05289

Figure 25—Timing Marks

! Important

- Whenever the engine is cranked remotely at the starter, with a special jumper cable or other means, the distributor primary lead or coil primary leads should be disconnected.
5. Compare the total lift recorded from the dial indicator with specifications.
 6. If camshaft readings for all lobes are within specifications, remove dial indicator assembly.
 7. Install the rocker arm and adjust the valves as previously outlined.

CAMSHAFT REPLACEMENT

↔ Remove or Disconnect (Figures 25, 26, and 27)

Tool Required:

J-5825-A Crankshaft Sprocket Puller

1. Battery negative cable.
2. Air cleaner.
3. Fan, shroud, and radiator.
4. Rocker arm covers, as outlined previously.
5. Water pump.
6. Torsional damper, as outlined previously.
7. Front cover, as outlined previously.
8. Distributor. Refer to ENGINE ELECTRICAL (SEC. 6D).
9. Intake manifold, as outlined previously.
10. Pushrods and hydraulic lifters, as outlined previously.
 - Align the timing marks (figure 25).
11. Camshaft sprocket bolts.
12. Camshaft sprocket and timing chain. The sprocket is a light interference fit on the camshaft. Tap the sprocket on its lower edge to loosen it.
13. Crankshaft sprocket (if required). Use J-5825 (figure 26).
14. Front engine mounting through bolts.

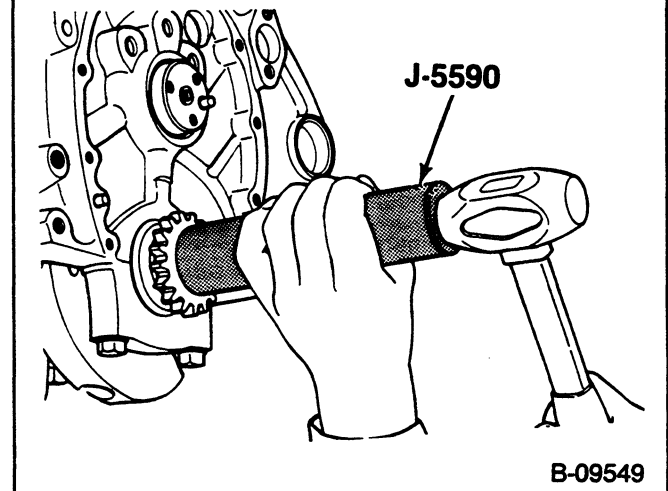
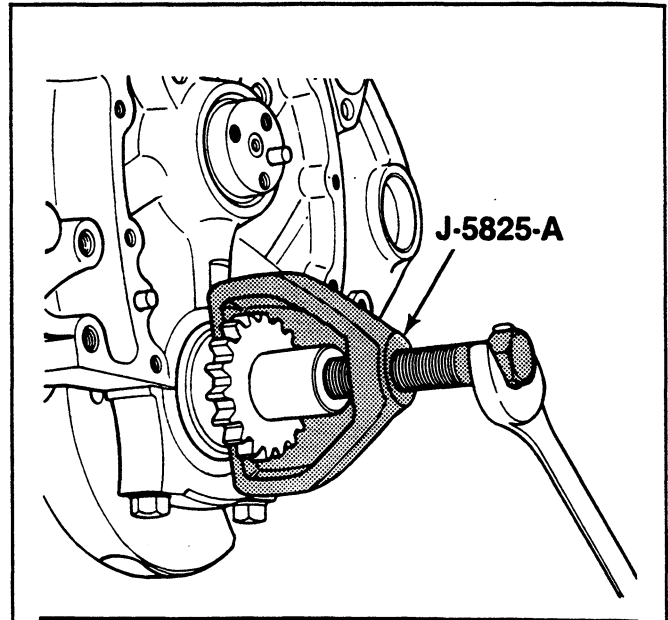

B-09549

Figure 26—Replacing the Crankshaft Sprocket

NOTICE: When raising or supporting the engine for any reason, do not use a jack under the oil pan, any sheet metal or crankshaft pulley. Due to the small clearance between the oil pan and the oil pump screen, jacking against the oil pan may cause it to be bent against the pump screen, resulting in a damaged oil pickup unit.

- Raise the engine.
15. Camshaft
 - Install two or three $\frac{5}{16}$ -18 bolts 100-125 mm (4-5 inches) long into the camshaft threaded holes. Use these bolts to handle the camshaft (figure 27).
 - Pull the camshaft from the block. Use care to prevent damage to the camshaft bearings.

Cleaning Inspection and Repair

Clean, inspect and repair or replace the camshaft and related components, as outlined in the proper unit repair manual.

The unit repair manual also describes camshaft bearing replacement.

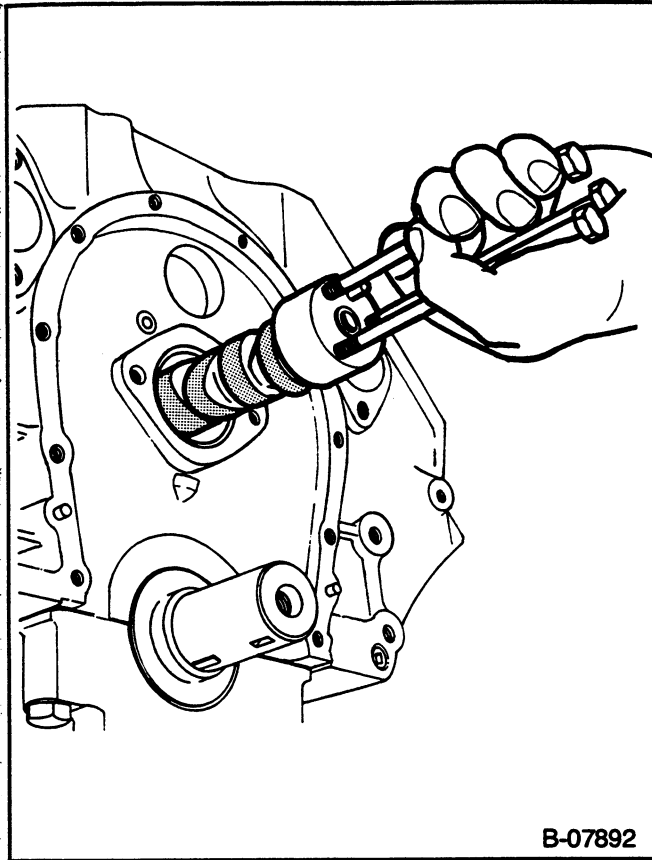

B-07892

Figure 27—Replacing the Camshaft

⇔ Install or Connect (Figures 25 through 27 and 35)

Tool Required:

J-5590 Crankshaft Sprocket Installer

- Coat the camshaft lobes and journals with a high quality engine oil supplement (GM Engine Oil Supplement or equivalent).
- 1. Two or three 5/16-18 bolts 100-125 mm (4-5 inches) long into the camshaft threaded holes. Use these bolts to handle the camshaft.
- 2. Camshaft to the engine (figure 27). Handle the camshaft carefully to prevent damage to the camshaft bearings.
 - Lower the engine.
- 3. Engine mount through-bolts.

NOTICE: See "Notice" on page 6A4-1 of this section.

🔩 Tighten

- Through-bolts to specifications. Refer to figure 35.
- 4. Crankshaft sprocket (if removed). Use J-5590 (figure 26). Make sure the timing mark faces outside.
- 5. Camshaft sprocket and timing chain.

! Important

- Line up the timing marks on the camshaft sprocket and crankshaft sprocket (figure 25).
- 6. Camshaft sprocket bolts.

🔩 Tighten

- Bolts to 24 N·m (18 ft. lbs.).
- 7. Hydraulic lifters and pushrods, as outlined previously.

! Important

- Replace all hydraulic lifters, change the engine oil and filter, and add GM Engine Oil Supplement (or equivalent) to the engine oil whenever a new camshaft is installed.

🔧 Adjust

- Valves, as outlined previously.
- 8. Intake manifold, as outlined previously.
- 9. Distributor. Refer to ENGINE ELECTRICAL (SEC. 6D).
- 10. Front cover, as outlined previously.
- 11. Torsional damper, as outlined previously.
- 12. Water pump.
- 13. Rocker arm covers, as outlined previously.
- 14. Fan, shroud, and radiator.
- 15. Air cleaner.
- 16. Battery negative cable.
 - Fill the cooling system with the proper quantity and grade of coolant.

CONNECTING ROD AND PISTON REPLACEMENT

⇔ Remove or Disconnect (Figure 28)

Tool Required:

J-5239 Guide Set

1. Cylinder head, as outlined previously.
2. Oil pan, as outlined previously.
3. Oil pump, as outlined previously (if necessary).
4. Ridge or deposits from the upper end of the cylinder bores.
 - Turn the crankshaft until the piston is at BDC.
 - Place a cloth on top of the piston.
 - Perform the cutting operation with a ridge reamer.
 - Turn the crankshaft until the piston is at TDC.
 - Remove the cloth and cuttings.
5. Connecting rod cap. Check the connecting rod and cap for identification marks. Mark the parts if required. The connecting rod and cap must be kept together as mating parts.
6. Connecting rod and piston.
 - Attach J-5239 to the connecting rod bolts (figure 28).
 - Use the long guide rod of J-5239 to push the connecting rod and piston out of the bore.
7. Connecting rod bearing.

Cleaning, Inspection, and Repair

Clean, inspect and repair or replace the components as necessary. Measure connecting rod bearing clearance, piston clearance, ring clearances, etc. Refer to the proper unit repair manual.

The unit repair manual contains information on:

- Connecting rod and piston.

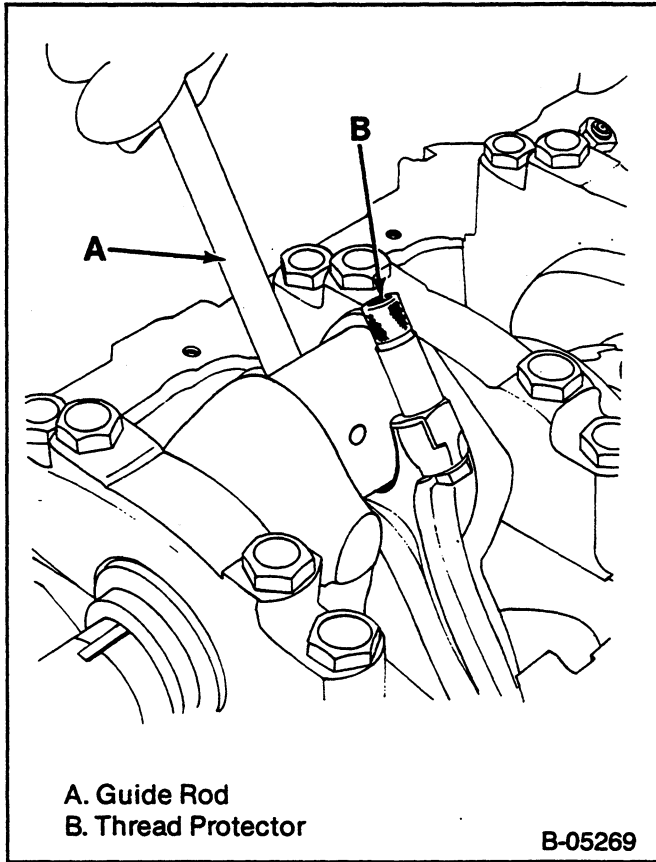

Figure 28—Replacing the Piston and Connecting Rod

- Piston rings.
- Connecting rod and crankpin.
- Cylinder bores.

Install or Connect (Figures 28 through 31)

Tools Required:

- J-5239 Connecting Rod Guide Set
- J-8037 Ring Compressor

- Make sure the cylinder walls are clean. Lubricate the cylinder wall lightly with engine oil.

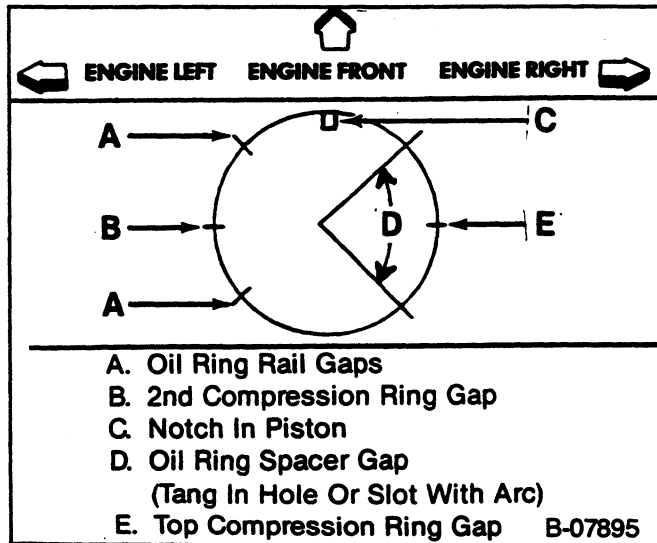

Figure 29—Piston Ring End Gap Locations

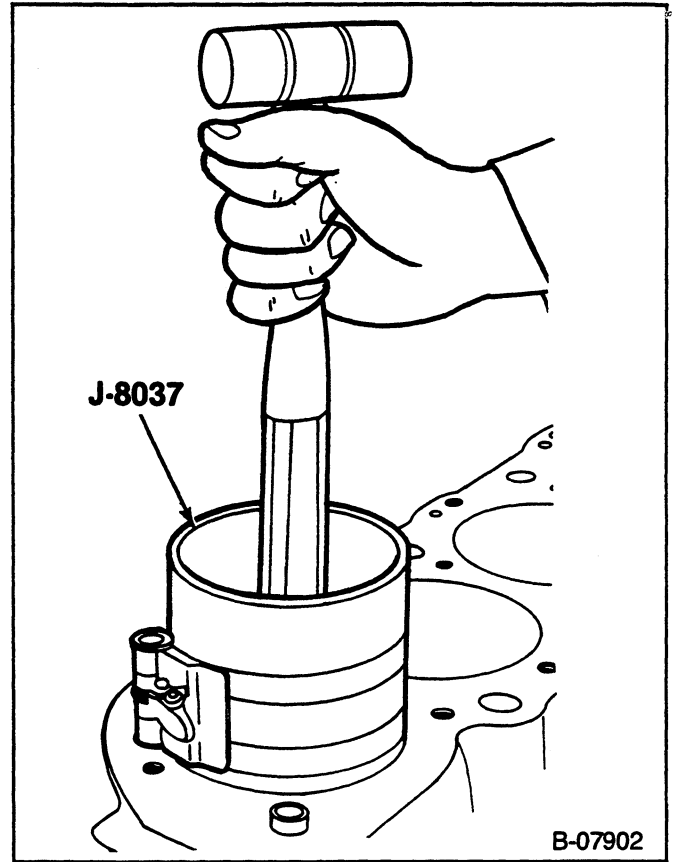

Figure 30—Installing the Piston

- Make sure the piston is installed in the matching cylinder.
1. Connecting rod bearings.
 - Be certain that the bearings are of the proper size.
 - Install the bearings in the connecting rod and connecting rod cap.
 - Lubricate the bearings with engine oil.
 2. Piston and connecting rod to the proper bore.
 - With the connecting rod cap removed, install J-5239 onto the connecting rod studs.
 - Locate the piston ring end gaps as shown in figure 29. Lubricate the piston and rings.
 - Without disturbing the ring end gap location, install J-8037 over the piston (figure 30).

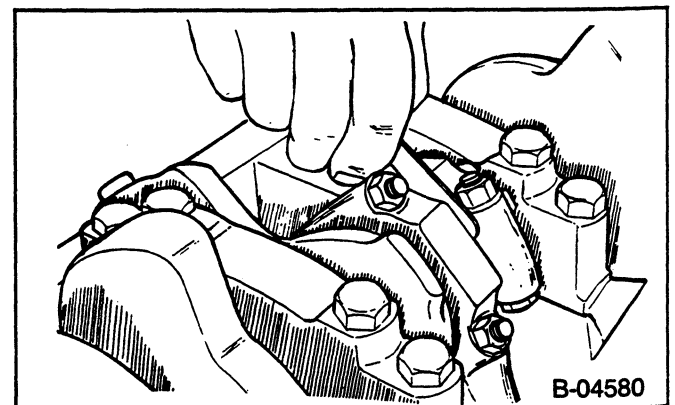

Figure 31—Measuring Connecting Rod Side Clearance

- The piston must be installed so that the notch in the piston faces the front of the engine (figure 29).
- Place the piston in its matching bore. The connecting rod bearing tang slots must be on the side opposite the camshaft. Using light blows with a hammer handle, tap the piston down into its bore (figure 30). At the same time, from beneath the vehicle guide the connecting rod to the crankpin with J-5239 (figure 28). Hold the ring compressor against the block until all rings have entered the cylinder bore.
- Remove J-5239 from the connecting rod bolts.

! Important

- Each connecting rod and bearing cap should be marked, beginning at the front of the engine. Cylinders 1, 3, 5 and 7 are the left bank and, 2, 4, 6, and 8 are the right bank. The numbers on the connecting rod and bearing cap must be on the same side when installed in the cylinder bore. If a connecting rod is ever transposed from one block or cylinder to another, new connecting rod bearings should be fitted and the connecting rod should be numbered to correspond with the new cylinder number.

Measure

- Connecting rod bearing clearance. Refer to the proper unit repair manual.
3. Connecting rod cap and bearing.
 4. Connecting rod cap nuts.

Tighten

- Connecting rod cap nuts to 60 N·m (45 ft. lbs.).

Measure

- Connecting rod side clearance. Use a feeler gage between the connecting rods (figure 31). The correct clearance is 0.006–0.014-inch.
5. Oil pump (if removed), as outlined previously.
 6. Oil pan and cylinder head, as outlined previously.

OIL FILTER BYPASS VALVE

↔ Remove or Disconnect (Figure 32)

1. Oil filter.

Inspect

- Bypass valve spring and valve disc for proper operation, cracks, and damage. If replacement is needed, the oil filter bypass valve (93) must be replaced, as follows:

2. Bolts (94).
3. Oil filter bypass valve.

Clean

- Valve chamber in the block.

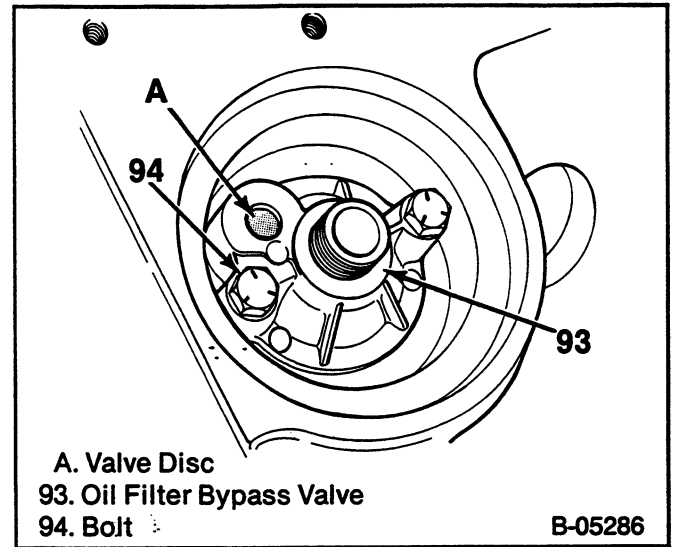

Figure 32—Oil Filter Bypass Valve

↔ Install or Connect (Figure 32)

1. Oil filter bypass valve (93).
2. Bolts (94).

Tighten

- Bolts (94) to 26 N·m (20 ft. lbs.).
3. Oil filter.
 4. Engine oil, as needed.

MAIN BEARING REPLACEMENT

↔ Remove or Disconnect (Figure 33)

Tool Required:

J-8080 Main Bearing Remover/Installer

1. Spark plugs.
2. Oil pan, as outlined previously.
3. Oil pump, as outlined previously.
4. Main bearing caps.

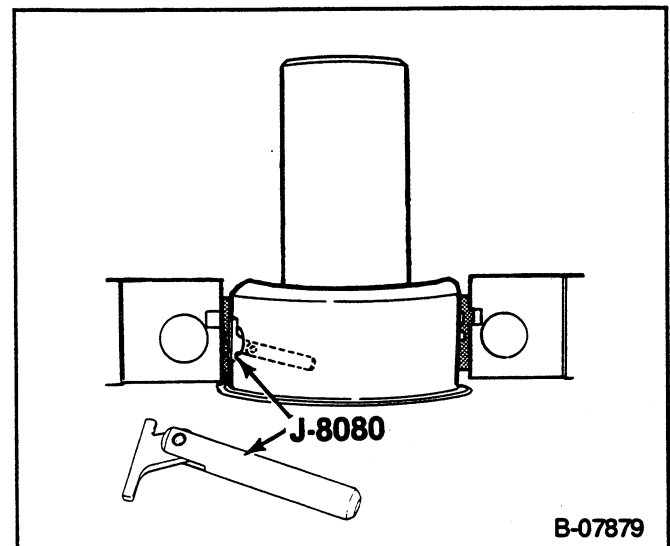

Figure 33—Removing the Main Bearing Insert

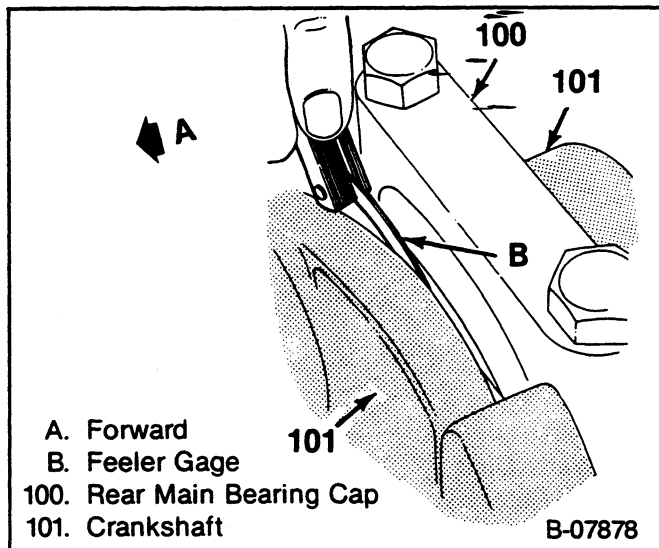

Figure 34—Measuring Crankshaft End Play

- Check the main bearing caps for location markings. Mark the caps if necessary. The caps must be returned to their original locations during assembly.
- Lower main bearing inserts from the main bearing caps.
 - Upper main bearing inserts.
 - Insert J-8080 into the crankshaft oil hole (figure 33).
 - Rotate the crankshaft to “turn” the bearing insert out of the block.

Cleaning, Inspection, and Repair

Clean, inspect, and repair or replace the components as required. Refer to the proper unit repair manual. The unit repair manual contains information on

- Crankshaft.
- Main and connecting rod bearings.
- Main bearing cap replacement (shimming procedure).

↔ Install or Connect (Figures 33 and 34)

Tool Required:
J-8080 Main Bearing Remover/Installer

- Upper main bearing inserts.
 - Insert tool J-8080 into a crankshaft main bearing oil hole (figure 33).
 - Apply engine oil to inserts of the proper size.
 - Insert the plain end (without the bearing tang) of the insert between the crankshaft and the notched side of the block.
 - Rotate the crankshaft to “roll” the insert into the block.
 - Remove the tool.
- Lower main bearing inserts to the main bearing caps.
 - Make sure the inserts are of the proper size.
 - Apply engine oil to the inserts.

📏 Measure

- Main bearing clearance. Refer to the proper unit repair manual. If the engine is in the vehicle, the crankshaft must be supported

upward to remove any clearance from the upper bearing. The total clearance can then be measured between the lower bearing and journal.

- Main bearing caps (except rear cap) and bolts to the block.

🔩 Tighten

- Main bearing cap bolts to specifications.
 - Outer bolts on #2, #3, and #4 main bearing caps: 95 N·m (70 ft. lbs.).
 - All others: 110 N·m (80 ft. lbs.).

- Rear main bearing cap and bolts.

🔩 Tighten

- Rear main bearing cap bolts temporarily to 14 N·m (10 ft. lbs.).

📏 Measure

- Crankshaft end play, as follows:
 - Tap the end of the crankshaft first rearward then forward with a lead hammer. This will line up the rear main bearing and crankshaft thrust surfaces.
 - Tighten the rear main bearing cap bolts to 110 N·m (80 ft. lbs.).
 - With the crankshaft forced forward, measure at the front end of the rear main bearing with a feeler gage (figure 34). The proper clearance is 0.002–0.006-inch.
 - If correct end play cannot be obtained, be certain that the correct size rear main bearing has been installed. Production engines may have rear main bearings that are 0.008-inch wider across the thrust faces than standard. Refer to the proper unit repair manual for more information.

- Oil pump, as outlined previously.
- Oil pan, as outlined previously.
- Spark plugs.

CRANKSHAFT REPLACEMENT

- Remove the engine, as outlined later.
- Refer to the proper unit repair manual for crankshaft replacement procedures.

FLYWHEEL REPLACEMENT

↔ Remove or Disconnect

- Transmission, flywheel housing, and clutch.
- Flywheel bolts.
- Flywheel.

🧼 Clean

- Mating surfaces of crankshaft and flywheel. Remove any burrs.



Inspect

- Flywheel for burning, scoring, warping, and wear. Replace the flywheel if necessary. Do not machine the flywheel.
- Flywheel ring gear for worn or broken teeth.

Flywheel Ring Gear Replacement

1. Use a torch to heat the gear around the entire circumference, then drive the gear off the flywheel, using care not to damage the flywheel.

NOTICE: Never heat starter gear to red heat as this will change metal structure.

2. Uniformly heat the flywheel gear to temperature which will expand the gear to permit installation. Temperature must not exceed 204°C (400°F).
3. As soon as the gear has been heated, install on the flywheel.



Install or Connect

1. Flywheel.
2. Flywheel bolts.



Tighten

- Flywheel bolts to 100 N·m (75 ft. lbs.).
3. Clutch, flywheel housing, and transmission.

ENGINE MOUNTINGS

NOTICE: Broken or deteriorated mountings can cause misaligned and eventual destruction of certain drive train components. When a single mounting breakage occurs, the remaining mountings are subjected to abnormally high stresses.

INSPECTING ENGINE MOUNTINGS

Front Engine Mountings

NOTICE: When raising or supporting the engine for any reason, do not use a jack under the oil pan, any sheet metal or crankshaft pulley. Due to the small clearance between the oil pan and the oil pump screen, jacking against the oil pan may cause it to be bent against the pump screen, resulting in a damaged oil pickup unit.

1. Raise the engine to remove weight from the mountings and to place a slight tension on the rubber cushion. Observe both mountings while raising the engine.
2. Replace the mounting if the following conditions exist:
 - Hard rubber surface covered with heat check cracks.
 - Rubber cushion separated from the metal plate of the mounting.
 - Rubber cushion split through the center.

3. If there is movement between a metal plate of the mounting and its attaching points, lower the engine and tighten the bolts or nuts attaching the mounting to the engine, frame, or bracket.

Rear Mountings

1. Push up and pull down on the transmission tailshaft. Observe the transmission mounting.
2. Replace the mounting if the following conditions exist:
 - Rubber cushion separated from the metal plate of the mounting.
 - Mounting bottomed out (tailshaft can be moved up but not down).
3. If there is relative movement between a metal plate of the mounting and its attaching point, tighten the bolts or nuts attaching the mounting to the transmission or crossmember.

FRONT MOUNTING REPLACEMENT



Remove or Disconnect (Figure 35)

NOTICE: When raising or supporting the engine for any reason, do not use a jack under the oil pan, any sheet metal or crankshaft pulley. Due to the small clearance between the oil pan and the oil pump screen, jacking against the oil pan may cause it to be bent against the pump screen, resulting in a damaged oil pickup unit.

- Support the engine with a suitable jack. Do not load the engine mounting.

1. Engine mounting through-bolt and nut.

NOTICE: Raise the engine only enough for sufficient clearance. Check for interference between the rear of the engine and the dash panel which could cause distributor housing damage.

- Raise the engine only enough to permit removal of the engine mounting.
2. Mounting assembly bolts, nuts, and washers.
 3. Mounting assembly.



Install or Connect (Figure 35)

1. Mounting assembly.

NOTICE: See "Notice" on page 6A4-1 of this section.

2. Mounting assembly bolts, nuts, and washers.



Tighten

- Fasteners to specifications. Refer to figure 35.
3. Engine mount through-bolt and nut lower the engine until the bolt can be inserted. Install the nut.



Tighten

- Through-bolt nut to specifications. Refer to figure 35.

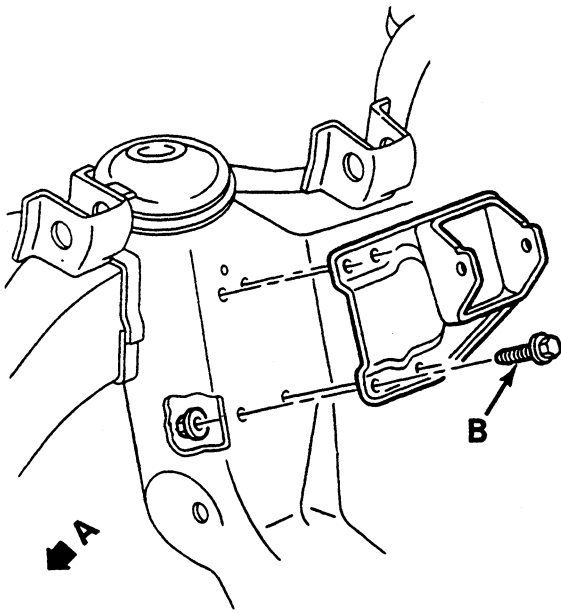

C MODELS

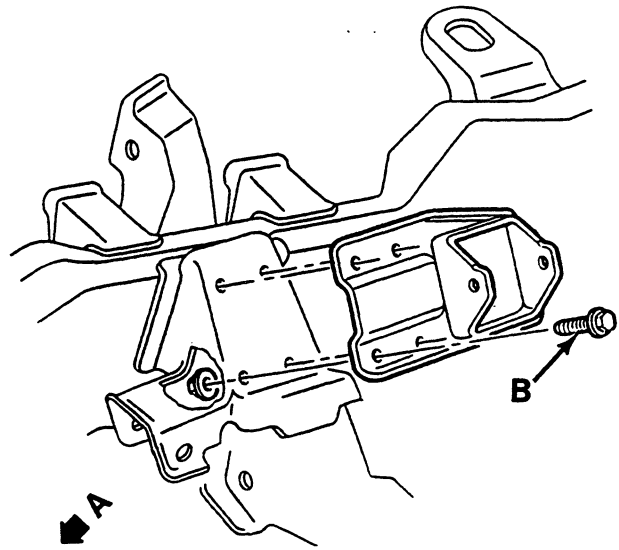

K MODELS

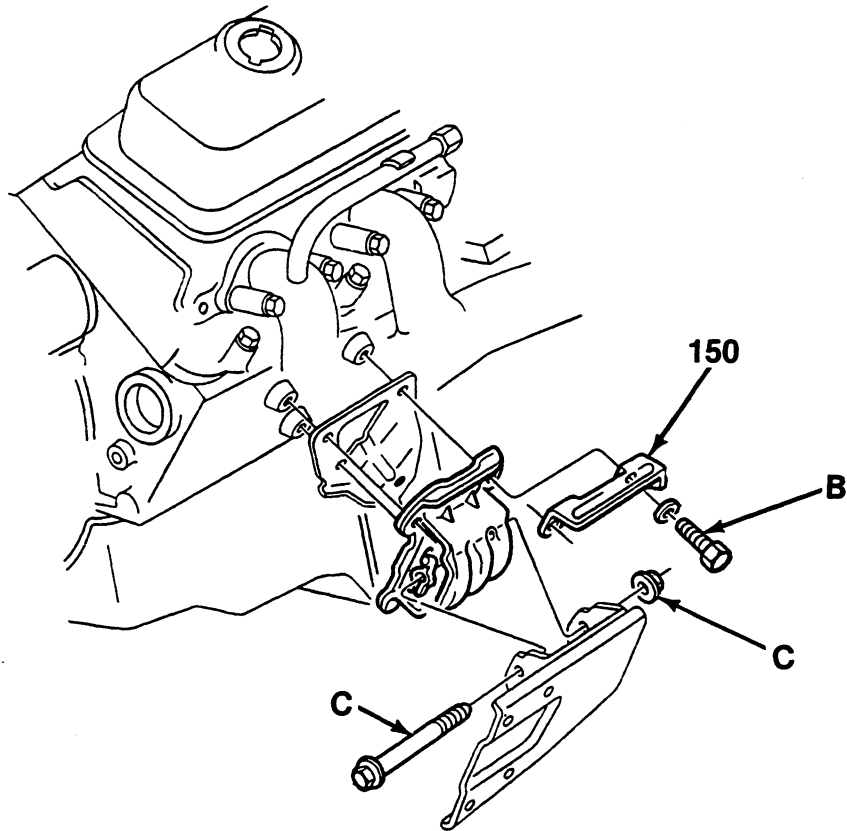

- A. Forward
- B. 60 N·m (45 ft. lbs.)
- C. Torque Bolt to 95 N·m (70 Ft. Lbs.) or, Torque Nut to 70 N·m (50 Ft. Lbs.)
- 150. Bracket (C15 Models)

F-03215

Figure 35—Front Engine Mounting

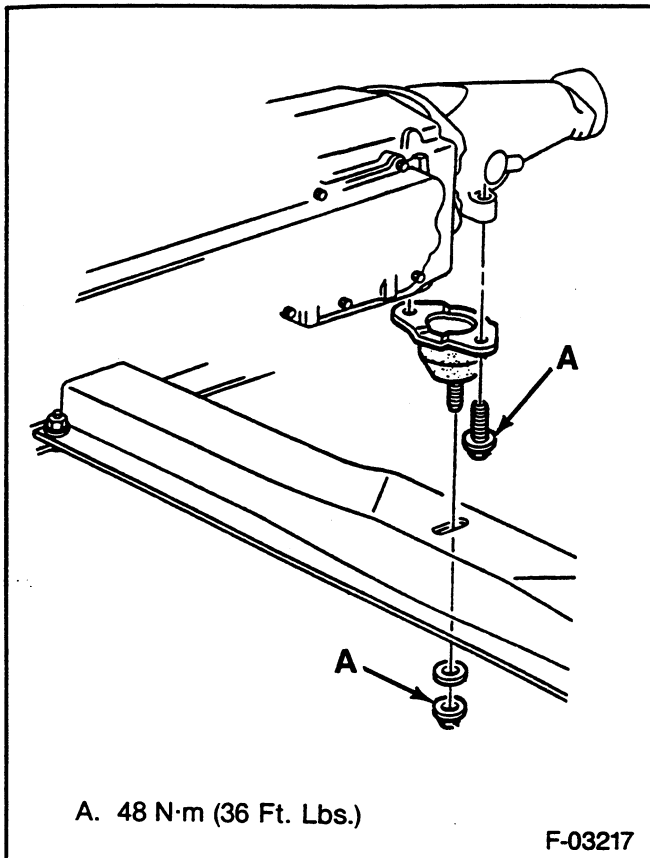

A. 48 N·m (36 Ft. Lbs.)

F-03217

Figure 36—Rear Engine Mounting (C Models)

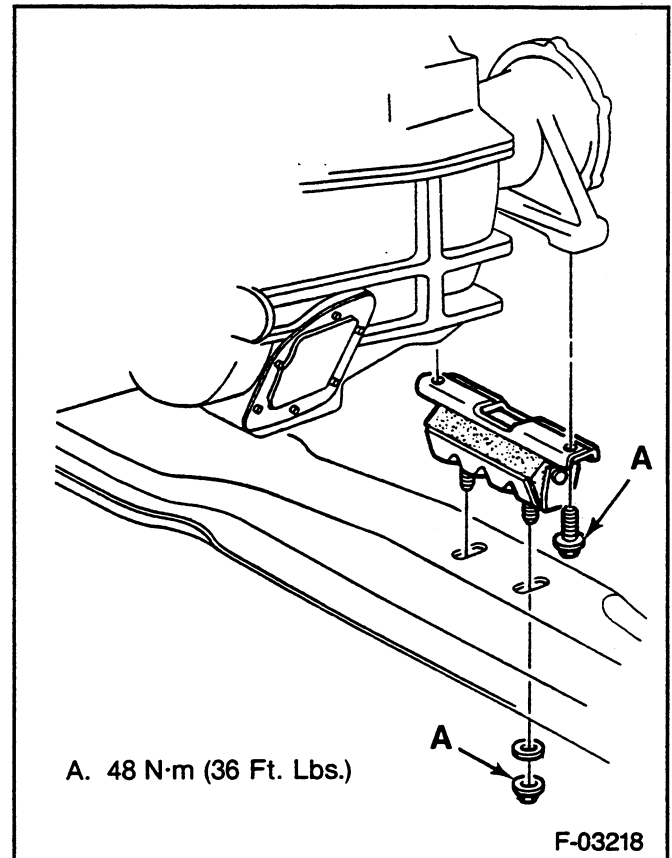

A. 48 N·m (36 Ft. Lbs.)

F-03218

Figure 37—Rear Engine Mounting (K Models)

REAR MOUNTING REPLACEMENT

↔ Remove or Disconnect (Figures 36 and 37)

NOTICE: When raising or supporting the engine for any reason, do not use a jack under the oil pan, any sheet metal or crankshaft pulley. Due to the small clearance between the oil pan and the oil pump screen, jacking against the oil pan may cause it to be bent against the pump screen, resulting in a damaged oil pickup unit.

- Support the rear of the engine to relieve the weight on the rear mountings.

1. Mounting to crossmember nut(s) and washer(s).
2. Mounting to transmission bolts and washers.

- Raise the rear of the engine only enough to permit removal of the mounting.

3. Mounting.

↔ Install or Connect (Figures 36 and 37)

1. Mounting.
 - Lower the rear of the engine.
2. Mounting to transmission bolts and washers.

NOTICE: See "Notice" on page 6A4-1 of this section.

3. Mounting to crossmember nut(s) and washer(s).

⌚ Tighten

- Fasteners to specifications. Refer to figures 36 and 37.

ENGINE REPLACEMENT

↔ Remove or Disconnect

1. Battery negative cable.
2. Hood.
 - Drain the cooling system.
3. Air cleaner.
4. Accessory drive belt.
5. Fan and water pump pulley.
6. Radiator and shroud.
7. Heater hoses at the engine.
8. Accelerator, cruise control, and detent linkage (if used) from TBI unit.
9. Air conditioning compressor (if used) and lay aside.
10. Power steering pump (if used) and lay aside.
11. Engine wiring harness from the engine.
12. Fuel lines.
13. Vacuum lines from the intake manifold.
 - Raise the vehicle. Support with suitable safety stands.
 - Drain the crankcase oil.
14. Exhaust pipes from the manifolds.
15. Strut rods at the engine mountings (if used).
16. Flywheel or torque converter underpan.
17. Wiring along oil pan rail (if used).
18. Starter.
19. Wiring, as necessary.

6A4-24 SMALL BLOCK

20. Converter to flex plate bolts.
 - Lower the vehicle.
 - Support the transmission.
 - Attach a suitable lifting fixture.
21. Bell housing to engine bolts.
22. Front engine mounting to frame bolts.
23. Engine.

Install or Connect (Figure 36)

1. Engine to the vehicle.
 - Raise the vehicle. Support with suitable safety stands.

NOTICE: See "Notice" on page 6A4-1 of this section.

2. Front engine mounting to frame bolts.

Tighten

- Fasteners to specifications. Refer to figure 36.
3. Bell housing to engine bolts. Remove the transmission support.

4. Converter to flex plate bolts.
5. Wiring, as required.
6. Starter.
7. Wiring along oil pan rail (if used).
8. Flywheel or torque converter underpan.
9. Strut rods at the engine mountings (if used).
10. Exhaust pipes to the manifolds.
 - Lower the vehicle.
11. Vacuum lines to the intake manifold.
12. Fuel line.
13. Engine wiring harness.
14. Power steering pump (if used).
15. Air conditioning compressor (if used).
16. Accelerator, cruise control, and detent linkages.
17. Heater hoses.
18. Radiator and shroud.
19. Accessory drive belt.
20. Air cleaner.
21. Hood.
22. Proper quantity and grade of coolant and crankcase oil.
23. Battery negative cable.

SPECIFICATIONS

ENGINE SPECIFICATIONS

All Specifications are in INCHES unless otherwise noted.

GENERAL DATA:				
Type		V8		
Displacement		5.0L (305 Cu. In.)	5.7L (350 Cu. In.)	
RPO (VIN Code)		L03 (H)	L05 (K) LT9 (M)	
Bore		3.736	4.00	
Stroke		3.480		
Compression Ratio		9.3 *	* 8.3:1	
Firing Order		1 - 8 - 4 - 3 - 6 - 5 - 7 - 2		
Oil Pressure		10 psi @ 500 RPM; 30-55 psi @ 2000 RPM		
CYLINDER BORE:				
Diameter		3.7350-3.7385	3.9995-4.0025	
Out Of Round	Production	0.001 (Maximum)		
	Service	0.002 (Maximum)		
Taper	Production	Thrust Side	0.0005 (Maximum)	
		Relief Side	0.001 (Maximum)	
	Service	0.001 (Maximum)		
PISTON:				
Clearance	Production		0.0007-0.0017	
	Service Limit		0.0027 (Maximum)	
PISTON RING:				
C O M P R E S S I O N	Groove Clearance	Production	Top	0.0012-0.0032
			2nd	
	Service Limit		Hi Limit Production + 0.001	
	Gap	Production	Top	0.010-0.020
			2nd	0.010-0.025
		Service Limit		Hi Limit Production + 0.010
O I L	Groove Clearance	Production	0.002-0.007	
		Service Limit	Hi Limit Production + 0.001	
	Gap	Production	0.015-0.055	
		Service Limit	Hi Production + 0.010	
PISTON PIN:				
Diameter		0.9269-0.9271		
Clearance In Piston	Production		0.0002-0.0007	
	Service Limit		0.001 (Maximum)	
Fit In Rod		0.0008-0.0016 Interference		

*8.6:1 with RPO-NA4
9.3:1 with RPO-NA1

6A4-26 SMALL BLOCK

SPECIFICATIONS ENGINE SPECIFICATIONS (CONT.)

All specifications are in INCHES unless otherwise noted.













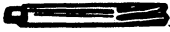

DISPLACEMENT			5.0L (305 Cu. In.)	5.7L (350 Cu. In.)
CRANKSHAFT:				
Main Journal	Diameter	#1	2.4484-2.4493	
		#2, #3, #4	2.4481-2.4490	
		#5	2.4479-2.4488	
	Taper	Production	0.0002 (Maximum)	
		Service Limit	0.001 (Maximum)	
	Out Of Round	Production	0.0002 (Maximum)	
Service Limit		0.001 (Maximum)		
Main Bearing Clearance	Production	#1	0.0008-0.0020	
		#2, #3, #4	0.0011-0.0023	
		#5	0.0017-0.0032	
	Service Limit	#1	0.0010-0.0015	
		#2, #3, #4	0.0010-0.0025	
		#5	0.0025-0.0035	
Crankshaft End Play			0.002-0.006	
Crankpin	Diameter		2.0988-2.0998	
	Taper	Production	0.0005 (Maximum)	
		Service Limit	0.001 (Maximum)	
	Out Round	Production	0.0005 (Maximum)	
		Service Limit	0.001 (Maximum)	
Rod Bearing Clearance	Production		0.0013-0.0035	
	Service Limit		0.003 (Maximum)	
Rod Side Clearance			0.006-0.014	
CAMSHAFT:				
Lobe Lift \pm 0.002	Intake		0.2484	0.2600
	Exhaust		0.2667	0.2733
Journal Diameter			1.8682-1.8692	
Camshaft End Play			0.004-0.012	
VALVE SYSTEM:				
Lifter			Hydraulic	
Rocker Arm Ratio			1.50:1	
Valve Lash	Intake		One Turn Down From Zero Lash	
	Exhaust			
Face Angle (Intake & Exhaust)			45°	
Seat Angle (Intake & Exhaust)			46°	
Seat Runout (Intake & Exhaust)			0.002 (Maximum)	
Seat Width	Intake		$\frac{1}{32}$ - $\frac{1}{16}$	
	Exhaust		$\frac{1}{16}$ - $\frac{3}{32}$	
Stem Clearance	Production	Intake	0.0010-0.0027	
		Exhaust	0.0010-0.0027	
	Service	Intake	High Limit Production + 0.001	
		Exhaust	High Limit Production + 0.002	
Valve Spring (Outer)	Free Length		2.03	
	Pressure lbs. @ in.	Closed	76-84 lbs. @ 1.70"	
		Open	194-206 lbs. @ 1.25"	
	Installed Height \pm $\frac{1}{32}$ "		$1\frac{23}{32}$	
Valve Spring Damper	Free Length		1.86	
	Approx. # of Coils		4	

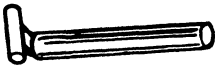
SPECIFICATIONS (CONT.)

TORQUE SPECIFICATIONS

Item	N·m	Ft. Lbs.	In. Lbs.
Rocker Arm Cover Bolts	11.3	—	100
Intake Manifold Bolts	48	35	—
Exhaust Manifold Bolts			
Two Center Bolts:	36	26	—
All Others:	28	20	—
Cylinder Head Bolts	90	65	—
Torsional Damper Bolt	95	70	—
Front Cover Bolts	11.3	—	100
Oil Pan Nuts at Corners	22.6	—	200
Oil Pan Bolts	11.3	—	100
Oil Pump Bolt	90	65	—
Rear Crankshaft Oil Seal Retainer Screws and Nuts	15.3	—	135
Camshaft Sprocket Bolts	24	18	—
Connecting Rod Cap Nuts	60	45	—
Oil Filter Bypass Valve Bolts	26	20	—
Main Bearing Cap Bolts			
Outer Bolts on #2, #3, and #4 Caps	95	70	—
All Others	110	80	—
Oil Pump Cover Bolts	9.0	—	80
Flywheel Bolts	100	75	—
Spark Plugs	30	22	—
Water Outlet Bolts	28	21	—
Water Pump Bolts	40	30	—
Flywheel Housing Bolts	44	32	—
Oil Pan Studs to Back or Rear Oil Seal Retainer	1.7	—	15

SPECIAL TOOLS

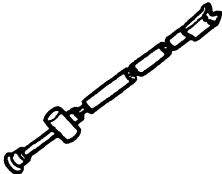
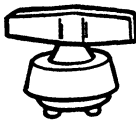
- | | | | | | |
|----|---|-----------|-----|---|-----------|
| 1. |  | J-23523-E | 10. |  | J-3049 |
| 2. |  | J-5892-B | 11. |  | J-5802-01 |
| 3. |  | J-23590 | 12. |  | J-5715 |
| 4. |  | J-35468 | 13. |  | J-6036 |
| 5. |  | J-8080 | 14. |  | J-6880 |
| 6. |  | J-8037 | 15. |  | J-5825-A |
| 7. |  | J-5239 | 16. |  | J-5590 |
| 8. |  | J-23738-A | 17. |  | J-8520 |
| 9. |  | J-9290-01 | 18. |  | J-35621 |

- | | |
|---|---|
| 1. Torsional Damper Remover and Installer | 10. Hydraulic Lifter Remover (Plier Type) |
| 2. Valve Spring Compressor | 11. Stud Remover |
| 3. Air Adapter | 12. Reamer (0.003-inch oversize) |
| 4. Crankshaft Seal Installer and Centering Tool | 13. Reamer (0.013-inch oversize) |
| 5. Main Bearing Replacer | 14. Stud Installer |
| 6. Piston Ring Compressor | 15. Crankshaft Gear Puller |
| 7. Guide Set | 16. Crankshaft Gear Installer |
| 8. Vacuum Pump | 17. Dial Indicator Adapter |
| 9. Hydraulic Lifter Remover (Slide Hammer Type) | 18. Rear Crankshaft Seal Installer |

C/K PICKUP

PICKUP MODEL SELECTOR

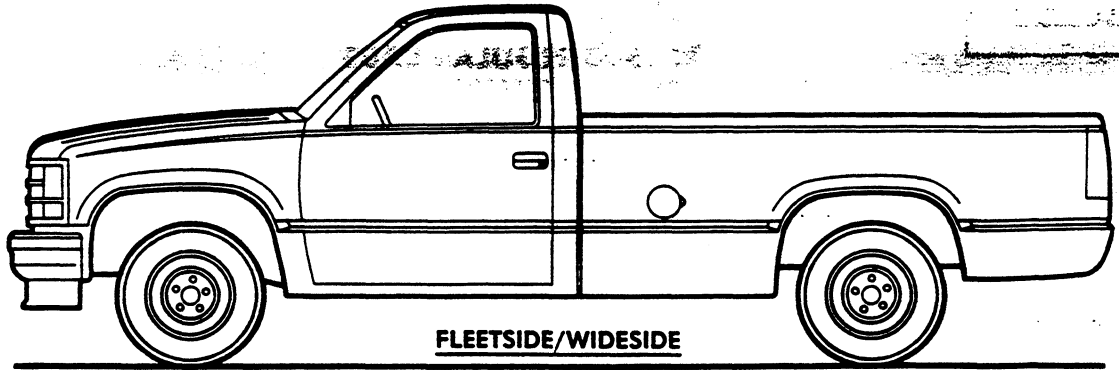

FLEETSIDE/WIDESIDE

REGULAR CAB

SERIES	MODEL NUMBER		BODY ORDERING CODE	
			GASOLINE MODELS	DIESEL MODELS
	6½' BOX	8' BOX	FLEETSIDE/WIDESIDE	FLEETSIDE/WIDESIDE
C1500	C10703	C10903	E63	—
C2500	—	C20903	E63	E63/B3J
C3500	—	C30903	E63	E63/B3J
K1500 (4X4)	K10703	K10903	E63	—
K2500 (4X4)	—	K20903	E63	E63/B3J
K3500 (4X4)	—	K30903	E63	E63/B3J

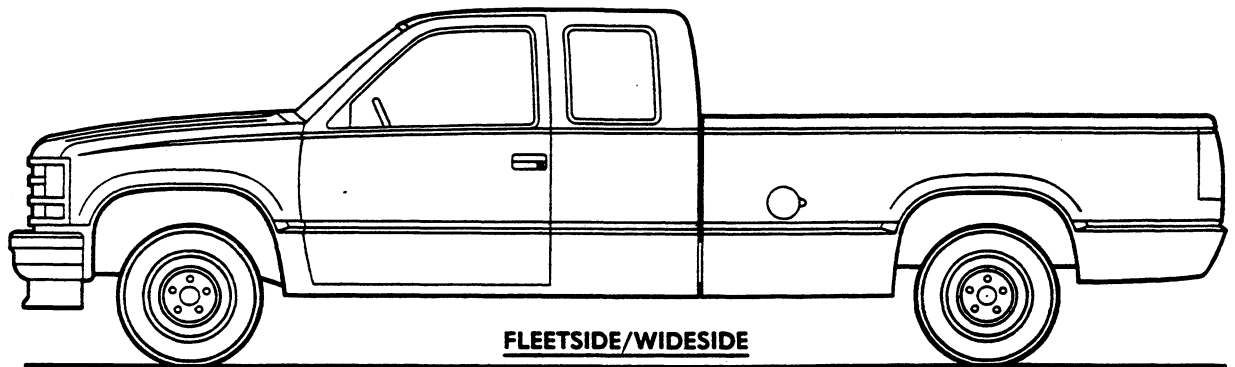

FLEETSIDE/WIDESIDE

EXTENDED CAB

SERIES	MODEL NUMBER	BODY ORDERING CODE 8' FLEETSIDE/WIDESIDE BOX	
		GASOLINE MODELS	DIESEL MODELS
C1500	C10953	E63	—
C2500	C20953	E63	E63/B3J
C3500	C30953	E63	E63/B3J
K1500	K10953	E63	—
K2500	K20953	E63	E63/B3J
K3500	K30953	E63	E63/B3J

PRELIMINARY INFORMATION—SUBJECT TO CHANGE

GASOLINE

C/K PICKUP—2-Wheel Drive

**C1500 REGULAR CABS
C1500 EXTENDED CABS**

STANDARD SPECIFICATIONS

Series	C1500 Regular Cab	C1500 Extended Cab
Engine		
Base Equip.	4.3 Liter, 262 EFI V6	
Clutch	11"; 124 sq. in.	
Air Filter	Oiled-paper Element	
Oil Filter	Throwaway Type	
Exhaust System	Single; Aluminized	
Emission Control Systems	Meet Government Requirements	
Suspension, Front	Independent; Coil Springs	
Capacity	2950 lb.	3600 lb.
Springs @ Ground	1500 lb. ea.	1800 lb. ea.
Shock Absorbers	25mm	
Suspension, Rear	Salisbury Axle; Hypoid Drive; Two-stage Multi-leaf Springs	
Axle Capacity	3750 lb.	
Axle Ratio	2.73	
Springs @ Ground	1875 lb. ea.	
Shock Absorbers	25mm dia.	
Brakes	Hydraulic; Self-adjusting	
Front	Disc; 11.86" Rotor	
Rear	Drum; 11" x 2"	
Booster	Single Diaphragm	
Parking	Cable to Rear Wheels	
Electrical	12 Volt; Negative Ground	
Battery—Freedom Type	525 CCA♦ @ 0°F.	
—Reserve Capacity	90 min. @ 80°F.	
Delcotron Generator	66 amp.	
Frame	Carbon Steel; 36,-39,000 psi	
Section Modulus	2.70	3.42
Fuel Tank (nominal capacity)	25 gal.	
Steering Gear Type	Integral Power	
Transmission	Fully Synchronized 4-Speed Manual	
Shift Location	Floor	
Tires	(5) P205/75R15	(5) P235/75R15
Wheels	(5) Disc	
Size	15" x 6"	

♦CCA-Cold Cranking Amps

PRELIMINARY INFORMATION—SUBJECT TO CHANGE

NOTES

GASOLINE

C/K PICKUP—2-Wheel Drive

— C2500 REGULAR CABS
C2500 EXTENDED CABS

STANDARD SPECIFICATIONS

Series	C2500 Regular Cab	C2500 Extended Cab
Engine	4.3 Liter, 262 EFI V6	
Base Equip.	11"; 124 sq. in.	
Clutch	Oiled-paper Element	
Air Filter	Throwaway Type	
Oil Filter	Single; Aluminized	
Exhaust System	Meet Government Requirements	
Emission Control Systems		
Suspension, Front	Independent; Coil Springs	
Capacity	3150 lb.	3600 lb.
Springs @ Ground	1800 lb. ea.	
Shock Absorbers	25mm dia.	
Suspension, Rear	Salisbury Axle; Hypoid Drive; Two-stage Multi-leaf Springs	
Axle Capacity	4800 lb.	
Axle Ratio	3.42	
Springs @ Ground	2400 lb. ea.	
Shock Absorbers	25mm dia.	
Brakes	Hydraulic, Self-adjusting	
Front	Disc; 11.57" Rotor	
Rear	Drum; 11.15" x 2.75"	
Booster	Dual Diaphragm	
Parking	Cable to Rear Wheels	
Electrical	12 Volt; Negative Ground	
Battery—Freedom Type	525 CCA♦ @ 0°F	
—Reserve Capacity	90 min. @ 80°F	
Delcotron Generator	66 amp.	
Frame	Carbon Steel; 36,-39,000 psi	
Section Modulus	2.70	3.42
Fuel Tank (nominal capacity)	25 gal.	
Steering Gear Type	Integral Power	
Transmission	5-Speed Manual w/Overdrive	
Shift Location	Floor	
Tires	(4) LT225/75R16D (8PR)	
Wheels	(4) Disc	
Size	16" x 6.5"	

♦CCA-Cold Cranking Amps

PRELIMINARY INFORMATION—SUBJECT TO CHANGE

C/K PICKUP—2-Wheel Drive

DIESEL

**C2500 REGULAR CABS
C2500 EXTENDED CABS**

STANDARD SPECIFICATIONS

Series	C2500 Regular Cab	C2500 Extended Cab
Engine	6.2 Liter, 379 Cu. In. V8 Diesel	
Base Equip.	12"; 150 sq. in.	
Clutch	Poly-wrapped, Oiled-paper Element	
Air Filter	Throwaway Type	
Oil Filter	Standard	
Oil Cooler	Dual; Aluminized	
Exhaust System	Meet Government Requirements	
Emission Control Systems		
Suspension, Front	Independent; Coil Springs	
Capacity	3400 lb.	3600 lb.
Springs @ Ground	1800 lb. ea.	
Shock Absorbers	25mm dia.	
Suspension, Rear	Salisbury Axle; Hypoid Drive; Two-stage Multi-leaf Springs	
Axle Capacity	4800 lb.	
Axle Ratio	3.42	
Springs, Main @ Ground	2400 lb. ea.	
Shock Absorbers	25mm dia.	
Brakes	Hydraulic, Self-adjusting	
Front	Disc; 11.57" Rotor	
Rear	Drum; 11.5" x 2.75"	
Booster	Hydraulic Power	
Parking	Cable to Rear Wheels	
Electrical	12 Volt; Negative Ground	
Battery—Freedom Type	Two: 550 CCA♦ ea. @ 0°F.	
— Reserve Capacity	115 min. ea. @ 80°F.	
Delcotron Generator	66 amp.	
Engine Block Heater	600 watts, 120 volts	
Frame	Carbon Steel; 36,-39,000 psi	
Section Modulus	2.70	3.42
Fuel Tank (nominal capacity)	25 gal.	
Steering Gear Type	Integral Power	
Transmission	4-Speed Manual (SM 465)	
Shift Location	Floor	
Tires	(4) LT 225/75R16D (8PR)	
Wheels	(4) Disc	
Size	16" x 6.5"	

♦CCA-Cold Cranking Amps

PRELIMINARY INFORMATION—SUBJECT TO CHANGE

GASOLINE**C/K PICKUP—2-Wheel Drive****C3500 REGULAR CABS
C3500 EXTENDED CABS****STANDARD SPECIFICATIONS**

Series	C3500 Regular Cab	C3500 Extended Cab
Engine Base Equip.	5.7 Liter, 350 EFI V8	
Clutch	12"; 150 sq. in.	
Air Filter	Oiled-paper Element	
Oil Filter	Throwaway Type	
Exhaust System	Single; Aluminized	
Emission Control Systems	Meet Government Requirements	
Suspension, Front	Independent; Coil Springs	
Capacity	3800 lb.	
Springs @ Ground	1900 lb. ea.	
Shock Absorbers	32mm	
Suspension, Rear	Salisbury Axle; Hypoid Drive; Two-stage Multi-leaf Springs	
Axle Capacity	6000 lb.	
Axle Ratio	3.42	
Springs @ Ground	3000 lb. ea.	
Shock Absorbers	32mm dia.	
Brakes	Hydraulic, Self-adjusting	
Front	Disc; 12.5" rotor	
Rear	Drum; 13" x .5"	
Booster	Hydraulic Power	
Parking	Cable to Rear Wheels	
Electrical	12 Volt; Negative Ground	
Battery—Freedom Type	525 CCA♦ ea. @ 0°F.	
— Reserve Capacity	90 min. @ 80°F.	
Delcotron Generator	66 amp.	
Frame	Carbon Steel; 36,-39,000 psi	
Section Modulus	5.38	6.21
Fuel Tank (Nominal Capacity)	25 gal.	
Steering Gear Type	Integral Power	
Transmission	4-Speed Manual (SM 465)	
Shift Location	Floor	
Tires	(4) LT 245/75R16E (10PR)	
Wheels	(4) Disc	
Size	16" x 6.5"	

♦CCA-Cold Cranking Amps

PRELIMINARY INFORMATION—SUBJECT TO CHANGE

C/K PICKUP—2-Wheel Drive

DIESEL

**C3500 REGULAR CABS
C3500 EXTENDED CABS**

STANDARD SPECIFICATIONS

Series	C3500 Regular Cab	C3500 Extended Cab
Engine Base Equip.	6.2 Liter, 379 Cu. In. V8 Diesel	
Clutch	12"; 150 sq. in.	
Air Filter	Poly-wrapped, Oiled-paper Element	
Oil Filter	Throwaway type	
Oil Cooler	Standard	
Exhaust System	Dual; Aluminized	
Emission Control Systems	Meet Government Requirements	
Suspension, Front	Independent; Coil Springs	
Capacity	3800 lb.	
Springs @ Ground	1900 lb. ea.	
Shock Absorbers	32mm	
Suspension, Rear	Salisbury Axle; Hypoid Drive; Two-stage Multi-leaf Springs	
Axle Capacity	6000 lb.	
Axle Ratio	3.73	
Springs @ Ground	3000 lb. ea.	
Shock Absorbers	32mm dia.	
Brakes	Hydraulic, Self-adjusting	
Front	Disc; 12.5" rotor	
Rear	Drum; 13" x 3.5"	
Booster	Hydraulic Power	
Parking	Cable to Rear Wheels	
Electrical	12 Volt; Negative Ground	
Battery—Freedom Type	Two; 540 CCA♦ ea. @ 0°F.	
—Reserve Capacity	115 min. @ 80°F.	
Delcotron Generator	66 amp.	
Engine Block Heater	600 watts, 120 volts	
Frame	Carbon Steel; 36,-39,000 psi	
Section Modulus	5.38	6.21
Fuel Tank (Nominal Capacity)	25 gal.	
Steering Gear Type	Integral Power	
Transmission	4-Speed Manual (SM 465)	
Shift Location	Floor	
Tires	(4) LT245/75R16E (10PR)	
Wheels	(4) Disc	
Size	16" x 6.5"	

♦CCA-Cold Cranking Amps

PRELIMINARY INFORMATION—SUBJECT TO CHANGE

GASOLINE

C/K PICKUP—4-Wheel Drive

**K1500 REGULAR CABS
K1500 EXTENDED CABS**

STANDARD SPECIFICATIONS

Series	K1500 Regular Cab	K1500 Extended Cab
Engine	4.3 Liter, 262 EFI V6	
Base Equip.	11"; 124 sq. in.	
Clutch	Oiled-paper Element	
Air Filter	Throwaway Type	
Oil Filter	Single; Aluminized	
Exhaust System	Meet Government Requirements	
Emission Control Systems		
Suspension, Front	Independent; Torsion Bars	
Capacity—117.5" WB	3350 lb.	—
—131.5" WB	3450 lb.	—
—155.5" WB	—	3925 lb.
Axle Ratio	3.42	
Springs @ Ground	1930 lb. ea.	
Shock Absorbers	25mm dia.	
Suspension, Rear	Salisbury Axle; Hypoid Drive; Two-stage Multi-leaf Springs	
Axle Capacity	3750 lb.	
Axle Ratio	3.42	
Springs @ Ground	1875 lb. ea.	
Shock Absorbers	25mm dia.	
Brakes	Hydraulic; Self-adjusting	
Front	Disc; 11.86" Rotor	
Rear	Drum; 11" x 2"	
Booster	—	
Parking	Cable to Rear Wheels	
Electrical	12 Volt; Negative Ground	
Battery—Freedom Type	525 CCA♦ @ 0°F.	
—Reserve Capacity	90 min. @ 80°F.	
Delcotron Generator	66 amp.	
Frame	Carbon Steel; 36,-39,000 psi	
Section Modulus	3.46	4.30
Fuel Tank (nominal capacity)	25 gal.	
Steering Gear Type	Integral Power	
Transmission	5-Speed Manual w/Overdrive	
Shift Location	Floor	
Tires	(5) LT225/75R16C (6PR)	(5) LT245/75R16C (6PR)
Wheels	(5) Disc	
Size	16" x 6"	

♦CCA-Cold Cranking Amps

PRELIMINARY INFORMATION—SUBJECT TO CHANGE

NOTES

GASOLINE

C/K PICKUP—4-Wheel Drive

**K2500 REGULAR CABS
K2500 EXTENDED CABS**

STANDARD SPECIFICATIONS

Series	K2500 Regular Cab	K2500 Extended Cab
Engine	4.3 Liter, 262 EFI V6	
Base Equip.	11"; 124 sq. in.	
Clutch	Oiled-paper Element	
Air Filter	Throwaway Type	
Oil Filter	Single; Aluminized	
Exhaust System	Meet Government Requirements	
Emission Control Systems		
Suspension, Front	Independent; Torsion Bars	
Capacity	3925 lb.	
Axle Ratio	3.42	
Springs @ Ground	2125 lb. ea.	
Shock Absorbers	25mm dia.	
Suspension, Rear	Salisbury Axle; Hypoid Drive; Two-stage Multi-leaf Springs	
Axle Capacity	4800 lb.	
Axle Ratio	3.42	
Springs @ Ground	2400 lb. ea.	
Shock Absorbers	25mm dia.	
Brakes	Hydraulic, Self-adjusting	
Front	Disc; 11.57" Rotor	
Rear	Drum; 11.15" x 2.75"	
Booster	Dual Diaphragm	
Parking	Cable to Rear Wheels	
Electrical	12 Volt; Negative Ground	
Battery – Freedom Type	525 CCA♦ @ 0°F.	
– Reserve Capacity	90 min. @ 80°F.	
Delcotron Generator	66 amp.	
Frame	Carbon Steel; 36,-39,000 psi	
Section Modulus	3.46	4.30
Fuel Tank (nominal capacity)	25 gal.	
Steering Gear Type	Integral Power	
Transmission	5-Speed Manual w/Overdrive	
Shift Location	Floor	
Tires	(4) LT225/75R16D (8PR)	(4) LT 245/75R16C (6PR)
Wheels	(4) Disc	
Size	16" x 6.5"	

♦CCA-Cold Cranking Amps

PRELIMINARY INFORMATION—SUBJECT TO CHANGE

C/K PICKUP—4-Wheel Drive

DIESEL

**K2500 REGULAR CABS
K2500 EXTENDED CABS**

STANDARD SPECIFICATIONS

Series	K2500 Regular Cab	K2500 Extended Cab
Engine	6.2 Liter, 379 Cu. In. V8 Diesel	
Base Equip.	12"; 150 sq. in.	
Clutch	Poly-wrapped, Oiled-paper Element	
Air Filter	Throwaway Type	
Oil Filter	Standard	
Oil Cooler	Single; Aluminized	
Exhaust System	Meet Government Requirements	
Emission Control Systems		
Suspension, Front	Independent; Torsion Bars	
Capacity	3925 lb.	
Springs @ Ground	2125 lb. ea.	
Shock Absorbers	25mm dia.	
Suspension, Rear	Salisbury Axle; Hypoid Drive; Two-stage Multi-leaf Springs	
Axle Capacity	4800 lb.	
Axle Ratio	3.42	
Springs, Main @ Ground	2400 lb. ea.	
Shock Absorbers	25mm dia.	
Brakes	Hydraulic, Self-adjusting	
Front	Disc; 11.57" Rotor	
Rear	Drum; 11.5" x 2.75"	
Booster	Hydraulic Power	
Parking	Cable to Rear Wheels	
Electrical	12 Volt; Negative Ground	
Battery—Freedom Type	Two: 550 CCA♦ ea. @ 0°F.	
— Reserve Capacity	115 min. ea. @ 80°F.	
Delcotron Generator	66 amp.	
Engine Block Heater	600 watts, 120 volts	
Frame	Carbon Steel; 36,-39,000 psi	
Section Modulus	3.46	4.30
Fuel Tank (nominal capacity)	25 gal.	
Steering Gear Type	Integral Power	
Transmission	— 4-Speed Manual (SM 465)	
Shift Location	Floor	
Tires	(4) LT 225/75R16D (8PR)	(4) LT245/75R16C (6PR)
Wheels	(4) Disc	
Size	16" x 6.5"	

♦CCA-Cold Cranking Amps

PRELIMINARY INFORMATION—SUBJECT TO CHANGE

GASOLINE**C/K PICKUP—4-Wheel Drive****K3500 REGULAR CABS
K3500 EXTENDED CABS****STANDARD SPECIFICATIONS**

Series	K3500 Regular Cab	K3500 Extended Cab
Engine		
Base Equip.	5.7 Liter, 350 EFI V8	
Clutch	12"; 150 sq. in.	
Air Filter	Oiled-paper Element	
Oil Filter	Throwaway Type	
Exhaust System	Single; Aluminized	
Emission Control Systems	Meet Government Requirements	
Suspension, Front	Independent; Torsion Bars	
Capacity	4250 lb.	
Axle Ratio	3.42	
Springs @ Ground	2125 lb. ea.	
Shock Absorbers	32mm	
Suspension, Rear	Salisbury Axle; Hypoid Drive; Two-stage Multi-leaf Springs	
Axle Capacity	6000 lb.	
Axle Ratio	3.42	
Springs @ Ground	3000 lb. ea.	
Shock Absorbers	32mm dia.	
Brakes	Hydraulic, Self-adjusting	
Front	Disc; 12.5" rotor	
Rear	Drum; 13" x .5"	
Booster	Hydraulic Power	
Parking	Cable to Rear Wheels	
Electrical	12 Volt; Negative Ground	
Battery—Freedom Type	525 CCA♦ ea. @ 0°F.	
—Reserve Capacity	90 min. @ 80°F.	
Delcotron Generator	66 amp.	
Frame	Carbon Steel; 36,-39,000 psi	
Section Modulus	5.61	6.48
Fuel Tank (Nominal Capacity)	25 gal.	
Steering Gear Type	Integral Power	
Transmission	4-Speed Manual (SM 465)	
Shift Location	Floor	
Tires	(4)-LT 245/75R16E (10PR)	
Wheels	(4) Disc	
Size	16" x 6.5"	

♦CCA-Cold Cranking Amps

PRELIMINARY INFORMATION—SUBJECT TO CHANGE

C/K PICKUP—4-Wheel Drive

DIESEL

**K3500 REGULAR CABS
K3500 EXTENDED CABS**

STANDARD SPECIFICATIONS

Series	K3500 Regular Cab	K3500 Extended Cab
Engine Base Equip.	6.2 Liter, 379 Cu. In. V8 Diesel	
Clutch	12"; 150 sq. in.	
Air Filter	Poly-wrapped, Oiled-paper Element	
Oil Filter	Throwaway type	
Oil Cooler	Standard	
Exhaust System	Single; Aluminized	
Emission Control Systems	Meet Government Requirements	
Suspension, Front	Independent; Torsion Bars	
Capacity	4250 lb.	
Axle Ratio	3.73	
Springs @ Ground	2125 lb. ea.	
Shock Absorbers	32mm	
Suspension, Rear	Salisbury Axle; Hypoid Drive; Two-stage Multi-leaf Springs	
Axle Capacity	6000 lb.	
Axle Ratio	3.73	
Springs @ Ground	3000 lb. ea.	
Shock Absorbers	32mm dia.	
Brakes	Hydraulic, Self-adjusting	
Front	Disc; 12.5" rotor	
Rear	Drum; 13" x 3.5"	
Booster	Hydraulic Power	
Parking	Cable to Rear Wheels	
Electrical	12 Volt; Negative Ground	
Battery—Freedom Type	Two; 540 CCA♦ ea. @ 0°F.	
—Reserve Capacity	115 min. @ 80°F.	
Delcotron Generator	66 amp.	
Engine Block Heater	600 watts, 120 volts	
Frame	Carbon Steel; 36,-39,000 psi	
Section Modulus	5.61	6.48
Fuel Tank (Nominal Capacity)	25 gal.	
Steering Gear Type	Integral Power	
Transmission	4-Speed Manual (SM 465)	
Shift Location	Floor	
Tires	(4) LT245/75R16E (10PR)	
Wheels	(4) Disc	
Size	16" x 6.5"	

♦CCA-Cold Cranking Amps

PRELIMINARY INFORMATION—SUBJECT TO CHANGE

GASOLINE

C/K PICKUP

C1500-3500 SERIES FLETSIDE/WIDESIDE PICKUP

Body Ordering Codes:

Regular Cab—E63

Extended Cab—E63

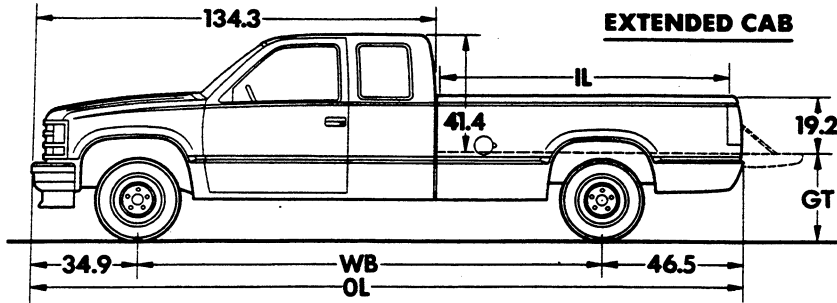

EXTENDED CAB

Sign Panel Area (side)
 Regular Cab—17" x 48½"
 Extended Cab—17" x 77½"

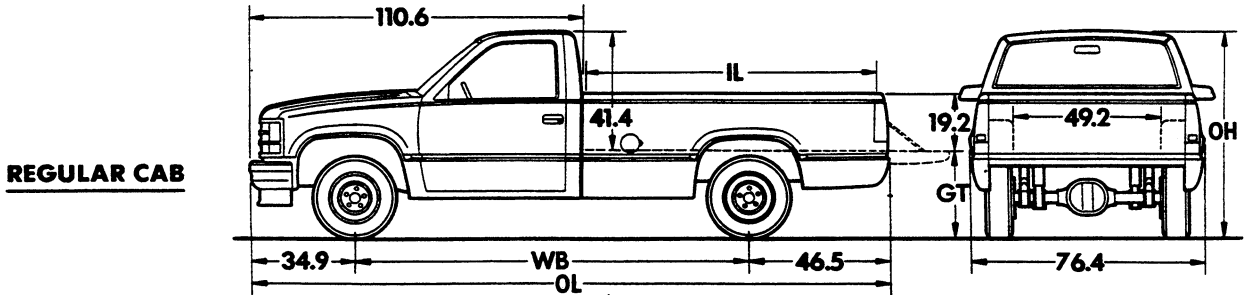

REGULAR CAB

Model	Wheelbase (in)	Body—Payload Weight Distribution*	
		% Front	% Rear
C1	117.5	1	99
C1-3	131.5	4	96
C1-3	155.5	3	97

*Estimate based on water-level loading.

Series	Ground Clearance (in)*	
	Front	Rear
C1 (03)	6.1	7.5
C1 (53)	7.2	7.1
C2 (03)	7.8	7.8
C2 (53)	7.9	7.7
C3 (03)	8.4	8.1
C3 (53)	8.4	8.0

Model	Engine No. Cyl.	Dimensions (in)*					Curb Weight (lb)			Model Weight (lb)*		
		WB	IL	OL	OH	GT	Front	Rear	Total	Front	Rear	Total

C1500 SERIES

C10703	6	117.5	78.7	194.1	70.4	29.0	2131	1524	3655	2351	1754	4105
C10903	6	131.5	97.6	212.9	70.4	29.0	2170	1559	3729	2416	1763	4179
C10953	6	131.5	97.6	236.9	70.5	29.0	2369	1705	4074	2644	1880	4524

C2500 SERIES

C20903	6	131.5	97.6	212.9	73.0	31.6	2245	1688	3933	2491	1892	4383
C20953	6	155.5	97.6	236.9	73.0	31.6	2415	1809	4224	2690	1984	4674

C3500 SERIES

C30903	6	131.5	97.6	212.9	75.5	34.0	2425	1868	4293	2671	2072	4743
C30953	6	155.5	97.6	236.9	75.5	34.0	2603	1959	4562	2878	2134	5012

*Dimensions with standard equipment, unloaded. *Model Weight includes Curb Weight plus occupants (standard seating capacity x 150 lb.). Total Model Weight may vary as much as ±50 lbs. to allow for production build variation.

PRELIMINARY INFORMATION—SUBJECT TO CHANGE

C/K PICKUP

C2500-3500 SERIES FLETSIDE/WIDESIDE PICKUP

DIESEL

Body Ordering Codes:
 Regular Cab—E63
 Extended Cab—E63

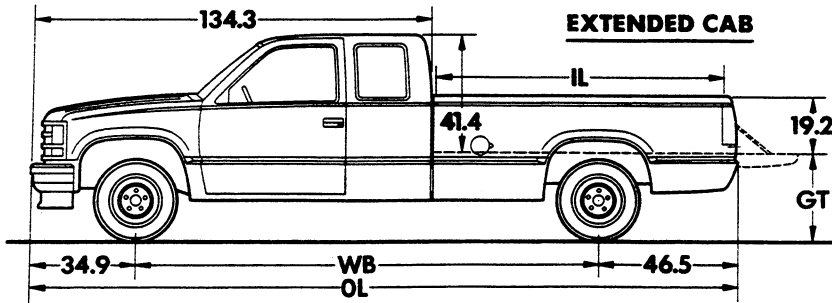

Sign Panel Area (side)
 Regular Cab—17" x 48 1/4"
 Extended Cab—17" x 77 1/2"

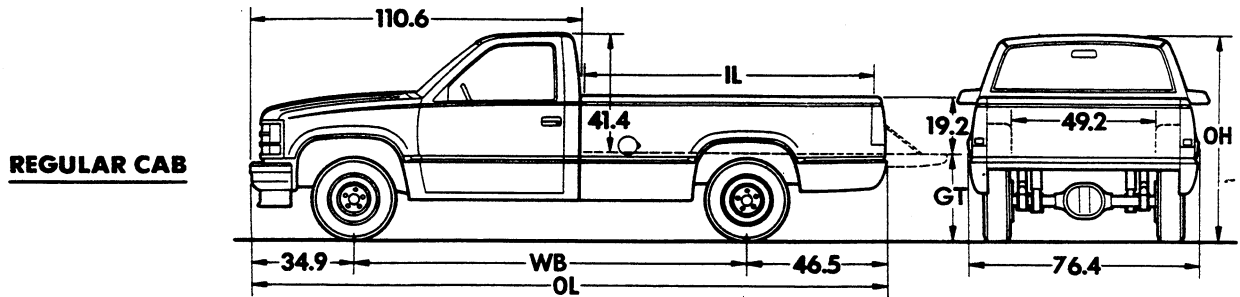

Model	Wheelbase (in)	Body—Payload Weight Distribution*	
		% Front	% Rear
C2-3	131.5	4	96
C2-3	155.5	3	97

*Estimate based on water-level loading.

Series	Ground Clearance (in)*	
	Front	Rear
C2 (03)	7.8	7.8
C2 (53)	7.9	7.7
C3 (03)	8.4	8.1
C3 (53)	8.4	8.0

Model	Engine No. Cyl.	Dimensions (in)*					Curb Weight (lb)			Model Weight (lb)*		
		WB	IL	OL	OH	GT	Front	Rear	Total	Front	Rear	Total
C2500 SERIES												
C20903	8	131.5	97.6	212.9	73.0	31.6	2637	1703	4340	2883	1907	4790
C20953	8	155.5	97.6	236.9	73.0	31.6	2807	1825	4632	3082	2000	5082
C3500 SERIES												
C30903	8	131.5	97.6	212.9	75.5	34.0	2820	1883	4703	3066	2087	5153
C30953	8	155.5	97.6	236.9	75.5	34.0	2999	1974	4973	3274	2149	5423

*Dimensions with standard equipment, unloaded. *Model Weight includes Curb Weight plus occupants (standard seating capacity x 150 lb.). Total Model Weight may vary as much as ±50 lbs. to allow for production build variation.

PRELIMINARY INFORMATION—SUBJECT TO CHANGE

C/K PICKUP

GASOLINE

K1500-3500 SERIES FLETSIDE/WIDESIDE PICKUP

Body Ordering Codes:
 Regular Cab—E63
 Extended Cab—E63

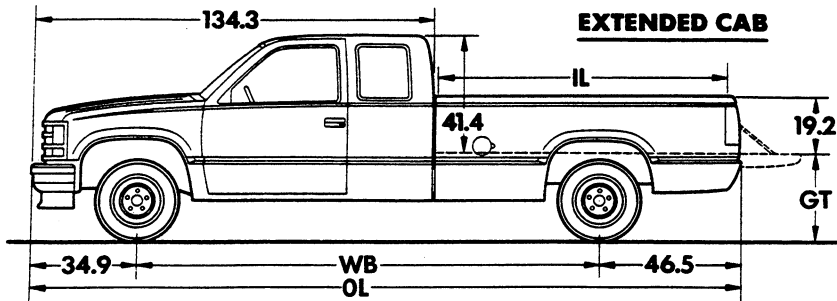

Sign Panel Area (side)
 Regular Cab—17" x 48¾"
 Extended Cab—17" x 77½"

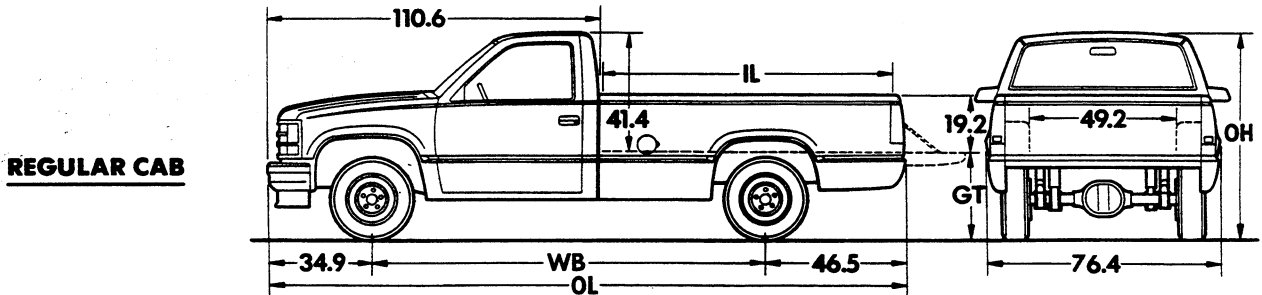

Model	Wheelbase (in)	Body—Payload Weight Distribution*	
		% Front	% Rear
K1	117.5	1	99
K1-3	131.5	4	96
K1-3	155.5	3	97

*Estimate based on water-level loading.

Series	Ground Clearance (in)*	
	Front	Rear
K1 (03)	8.6	9.0
K1 (53)	9.2	9.6
K2 (03)	8.7	7.7
K2 (53)	9.2	8.2
K3 (03)	7.8	8.1
K3 (53)	7.7	8.1

Model	Engine No. Cyl.	Dimensions (in)*					Curb Weight (lb)			Model Weight (lb)*		
		WB	IL	OL	OH	GT	Front	Rear	Total	Front	Rear	Total

K1500 SERIES

K10703	6	117.5	78.4	194.1	73.8	32.3	2431	1666	4097	2651	1896	4547
K10903	6	131.5	97.6	212.9	73.8	32.3	2486	1692	4178	2732	1896	4628
K10953	6	155.5	97.6	236.9	73.9	32.3	2695	1826	4521	2970	2001	4971

K2500 SERIES

K20903	6	131.5	97.6	212.9	74.3	32.9	2524	1761	4285	2770	1965	4735
K20953	6	155.5	97.6	236.9	74.5	32.9	2708	1872	4580	2983	2047	5030

K3500 SERIES

K30903	6	131.5	97.6	212.9	75.8	34.4	2755	1928	4683	3001	2132	5133
K30953	6	155.5	97.6	236.9	76.0	34.4	2934	2026	4960	3209	2201	5410

*Dimensions with standard equipment, unloaded. *Model Weight includes Curb Weight plus occupants (standard seating capacity x 150 lb). Total Model Weight may vary as much as ±50 lbs. to allow for production build variation.

PRELIMINARY INFORMATION—SUBJECT TO CHANGE

C/K PICKUP

K2500-3500 SERIES FLETSIDE/WIDESIDE PICKUP

DIESEL

Body Ordering Codes:

Regular Cab—E63

Extended Cab—E63

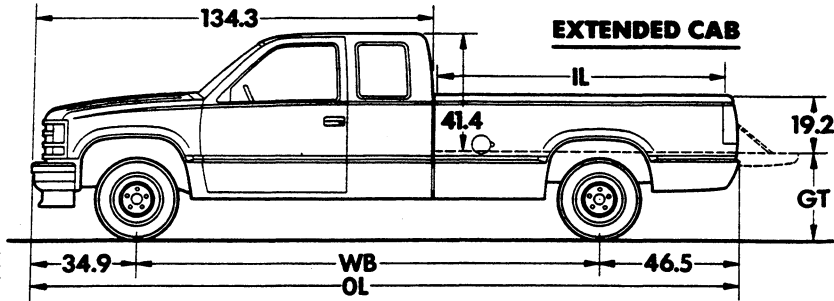

Sign Panel Area (side)
 Regular Cab—17" x 48¾"
 Extended Cab—17" x 77½"

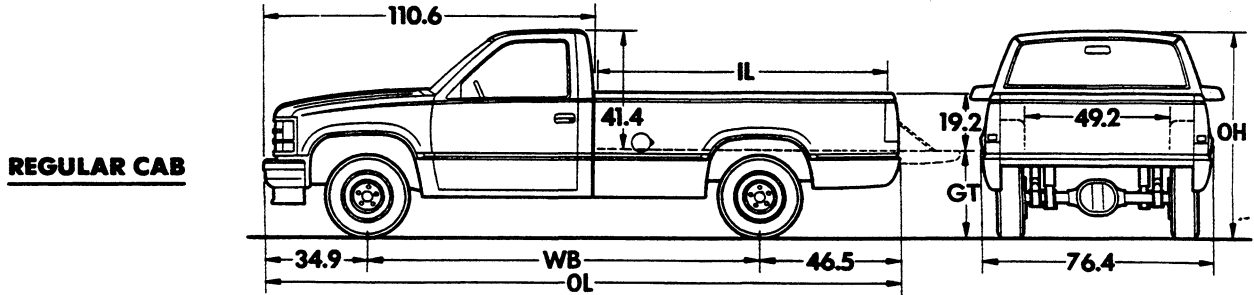

Model	Wheelbase (in)	Body—Payload Weight Distribution*	
		% Front	% Rear
K2-3	131.5	4	96
K2-3	155.5	3	97

*Estimate based on water-level loading.

Series	Ground Clearance (in)*	
	Front	Rear
K2 (03)	8.7	7.7
K2 (53)	9.2	8.2
K3 (03)	7.8	8.1
K3 (53)	7.7	8.1

Model	Engine No. Cyl.	Dimensions (in)*					Curb Weight (lb)			Model Weight (lb)*		
		WB	IL	OL	OH	GT	Front	Rear	Total	Front	Rear	Total

K2500 SERIES

K20903	8	131.5	97.6	212.9	74.3	32.9	2916	1776	4692	3162	1980	5142
K20953	8	155.5	97.6	236.9	74.5	32.9	3100	1888	4988	3375	2063	5438

K3500 SERIES

K30903	8	131.5	97.6	212.9	75.8	34.4	3150	1943	5093	3396	2147	5543
K30953	8	155.5	97.6	236.9	76.0	34.4	3330	2041	5371	3605	2216	5821

*Dimensions with standard equipment, unloaded. *Model Weight includes Curb Weight plus occupants (standard seating capacity x 150 lb). Total Model Weight may vary as much as ±50 lbs. to allow for production build variation.

PRELIMINARY INFORMATION—SUBJECT TO CHANGE

**C/K PICKUP
POWER TEAMS
ALL STATES EXCEPT CALIFORNIA
C/K1500 SERIES**

POWER TEAMS (MUST ORDER ENGINE, TRANSMISSION AND REAR AXLE)
(Consult GVWR Selector and Tire Chart to insure tire capacity and availability)

ENGINE	TRANSMISSION				AXLES					GVWR
	4-SP	5-SP	AUTO		2.73	3.08	3.42	3.73	4.10	
W/NA5 STANDARD EMISSION EQUIPMENT										
-C10703-C10903										
LB4 V6 4.3 Liter (262 Cu In)-EFI	MC0				GQ1	GU4	—	—	—	52/5600
	#MM4	MM5	MX1		GQ1	GU4	GU6	—	—	52/5600
L03 V8 5.0 Liter (305 Cu In)-EFI		MM5	MX0		—	GQ1	GU6	—	—	52/5600
			MX1/0		GQ1	GU4	GU6	—	—	52/5600
L05 V8 5.7 Liter (350 Cu In)-EFI	#MM4	MM5			—	GQ1	GU6	—	—	52/5600
			MX0		—	GQ1	GU6	GT4	—	52/5600
-C10953										
LB4 V6 4.3 Liter (262 Cu In)-EFI	MC0				GQ1	GU4	—	—	—	6000
	MM4	MM5	MX1		GQ1	GU4	GU6	—	—	6000
L03 V8 5.0 Liter (305 Cu In)-EFI		MM5	MX0		—	GQ1	GU6	—	—	6000
			MX1/0		GQ1	GU4	GU6	—	—	6000
L05 V8 5.7 Liter (350 Cu In)-EFI	MM4	MM5			—	GQ1	GU6	GT4	—	6000
			MX0		—	GQ1	GU6	—	—	6000
-K10703-K10903										
LB4 V6 4.3 Liter (262 Cu In)-EFI	MM4	* MM5	MX1/0		—	—	GQ1	%GT4	—	5600
L03 V8 5.0 Liter (305 Cu In)-EFI		* MM5	MX1/0		—	—	GQ1	GT4	—	5600
L05 V8 5.7 Liter (350 Cu In)-EFI	MM4	* MM5	MX0		—	—	GQ1	GT4	—	5600
-K10953										
LB4 V6 4.3 Liter (262 Cu In)-EFI	MM4	* MM5	MX1/0		—	—	GQ1	%GT4	—	6200
L03 V8 5.0 Liter (305 Cu In)-EFI		* MM5	MX1/0		—	—	GQ1	GT4	—	6200
L05 V8 5.7 Liter (350 Cu In)-EFI	MM4	* MM5	MX0		—	—	GQ1	GT4	—	6200
W/NA6 HIGH ALTITUDE EMISSION EQUIPMENT										
-C10703-C10903										
LB4 V6 4.3 Liter (262 Cu In)-EFI	MC0				—	GQ1	—	—	—	52/5600
	#MM4	MM5	MX1		—	GQ1	GU6	—	—	52/5600
L03 V8 5.0 Liter (305 Cu In)-EFI			MX0		—	—	GQ1	%GT4	—	52/5600
		MM5	MX1/0		—	GQ1	GU6	—	—	52/5600
L05 V8 5.7 Liter (350 Cu In)-EFI	#MM4	MM5			—	GQ1	GU6	—	—	52/5600
			MX0		—	GQ1	GU6	GT4	—	52/5600
-C10953										
LB4 V6 4.3 Liter (262 Cu In)-EFI	MC0				—	GQ1	—	—	—	6000
	MM4				—	—	GQ1	—	—	6000
		MM5	MX0		—	—	GQ1	%GT4	—	6000
			MX1		—	GQ1	GU6	—	—	6000
L03 V8 5.0 Liter (305 Cu In)-EFI		MM5	MX1/0		—	GQ1	GU6	—	—	6000
L05 V8 5.7 Liter (350 Cu In)-EFI	MM4	MM5			—	GQ1	GU6	—	—	6000
			MX0		—	GQ1	GU6	GT4	—	6000

% Reqs KC4 Eng. Oil Cooler
≠ N/A C10703 Model
* Standard Transmission

PRELIMINARY INFORMATION—SUBJECT TO CHANGE

**C/K PICKUP
POWER TEAMS
ALL STATES EXCEPT CALIFORNIA
C/K1500 SERIES**

POWER TEAMS (MUST ORDER ENGINE, TRANSMISSION AND REAR AXLE)
(Consult GVWR Selector and Tire Chart to insure tire capacity and availability)

ENGINE	TRANSMISSION			AXLES					GVWR
	4-SP	5-SP	AUTO	2.73	3.08	3.42	3.73	4.10	
-K10703-K10903									
LB4 V6 4.3 Liter (262 Cu In)-EFI	MM4	* MM5	MX1/0	—	—	GQ1	%GT4	—	5600
L03 V8 5.0 Liter (305 Cu In)-EFI		* MM5	MX1/0	—	—	GQ1	GT4	—	5600
L05 V8 5.7 Liter (350 Cu In)-EFI	MM4	* MM5	MX0	—	—	GQ1	GT4	—	5600
-K10953									
LB4 V6 4.3 Liter (262 Cu In)-EFI	MM4	* MM5	MX1/0	—	—	GQ1	%GT4	—	6200
L03 V8 5.0 Liter (305 Cu In)-EFI		* MM5		—	—	GQ1	GT4	—	6200
			MX1/0	—	—	GQ1	GT4	GT5	6200
L05 V8 5.7 Liter (350 Cu In)-EFI	MM4	* MM5		—	—	GQ1	GT4	—	6200
			MX0	—	—	GQ1	GT4	GT5	6200

**CALIFORNIA ONLY
C/K1500 SERIES**

ENGINE	TRANSMISSION			AXLES					GVWR
	4-SP	5-SP	AUTO	2.73	3.08	3.42	3.73	4.10	
W/YF5 CALIFORNIA EMISSION REQUIREMENTS									
-C10703-C10903									
LB4 V6 4.3 Liter (262 Cu In)-EFI	MCO				GQ1	GU4	—	—	52/5600
	#MM4	MM5	MX0		—	GQ1	GU6	—	52/5600
L03 V8 5.0 Liter (305 Cu In)-EFI			MX0		GQ1	GU4	GU6	—	52/5600
L05 V8 5.7 Liter (350 Cu In)-EFI			MX0		—	GQ1	GU6	GT4	52/5600
-C10953									
LB4 4.3 Liter (262 Cu In)-EFI	MCO				GQ1	GU4	—	—	6000
	MM4	MM5	MX0		—	GQ1	GU6	—	6000
L03 V8 5.0 Liter (305 Cu In)-EFI			MX0		GQ1	GU4	GU6	—	6000
L05 V8 5.7 Liter (350 Cu In)-EFI			MX0		—	GQ1	GU6	GT4	6000
-K10703-K10903									
LB4 V6 4.3 Liter (262 Cu In)-EFI	MM4	* MM5	MX0		—	—	GQ1	%GT4	5600
L03 V8 5.0 Liter (305 Cu In)-EFI			MX0		—	—	GQ1	GT4	5600
L05 V8 5.7 Liter (350 Cu In)-EFI			MX0		—	—	GQ1	GT4	5600
-K10953									
LB4 V6 4.3 Liter (262 Cu In)-EFI	MM4	* MM5	MX0		—	—	GQ1	%GT4	6200
L03 V8 5.0 Liter (305 Cu In)-EFI			MX0		—	—	GQ1	GT4	6200
L05 V8 5.7 Liter (350 Cu In)-EFI			MX0		—	—	GQ1	GT4	6200

%Reqs KC4 Eng. Oil Cooler
#N/A C10703
* Standard Transmission

PRELIMINARY INFORMATION—SUBJECT TO CHANGE

**C/K PICKUP
POWER TEAMS
ALL STATES EXCEPT CALIFORNIA
C/K2500 SERIES**

POWER TEAMS (MUST ORDER ENGINE, TRANSMISSION AND REAR AXLE)
(Consult GVWR Selector and Tire Chart to insure tire capacity and availability)

ENGINE	TRANSMISSION			AXLES			GVWR	
	4-SP	5-SP	AUTO	3.42	3.73	4.10		
W/NA5 STANDARD EMISSION EQUIPMENT								
-C20903-C20953								
LB4 V6 4.3 Liter (262 Cu In)-EFI	MM4	* MM5	MX1		GQ1	%GT4	—	7200
			MX0		GQ1	%GT4	%GT5	7200
L03 V8 5.0 Liter (305 Cu In)-EFI		* MM5			GQ1	GT4	—	7200
			MX1/O		GQ1	GT4	GT5	7200
L05 V8 5.7 Liter (350 Cu In)-EFI	MM4	* MM5			GQ1	GT4	—	7200
			MX0		GQ1	GT4	GT5	7200
LH6 Diesel 6.2 Liter V8 (379 Cu In) (Reqs B3J)	MM4		MX0		GQ1	GT4	—	7200
-K20903-K20953								
LB4 V6 4.3 Liter (262 Cu In)-EFI	MM4	* MM5	MX1		GQ1	%GT4	—	7200
			MX0		GQ1	%GT4	%GT5	7200
L03 V8 5.0 Liter (305 Cu In)-EFI		* MM5			GQ1	GT4	—	7200
			MX1/O		GQ1	GT4	GT5	7200
L05 V8 5.7 Liter (350 Cu In)-EFI	MM4	* MM5			GQ1	GT4	—	7200
			MX0		GQ1	GT4	GT5	7200
LH6 Diesel 6.2 Liter V8 (379 Cu In) (Reqs B3J)	MM4		MX0		GQ1	GT4	GT5	7200
W/NA6 HIGH ALTITUDE EMISSION EQUIPMENT								
-C20903-C20953								
LB4 V6 4.3 Liter (262 Cu In)-EFI	MM4	* MM5	MX1		—	%GQ1	—	7200
			MX0		—	%GQ1	%GT5	7200
L03 V8 5.0 Liter (305 Cu In)-EFI			MX1/O		GQ1	GT4	GT5	7200
		* MM5			GQ1	GT4	—	7200
L05 V8 5.7 Liter (350 Cu In)-EFI	MM4	* MM5			GQ1	GT4	—	7200
			MX0		GQ1	GT4	GT5	7200
LH6 Diesel 6.2 Liter V8 (379 Cu In) (Reqs B3J)	MM4		MX0		—	GQ1	GT5	7200
-K20903-K20953								
LB4 V6 4.3 Liter (262 Cu In)-EFI	MM4	* MM5	MX1		GQ1	%GT4	—	7200
			MX0		—	%GQ1	%GT5	7200
L03 V8 5.0 Liter (305 Cu In)-EFI		* MM5			GQ1	GT4	—	7200
			MX1/O		GQ1	GT4	GT5	7200
L05 V8 5.7 Liter (350 Cu In)-EFI	MM4	* MM5			GQ1	GT4	—	7200
			MX0		GQ1	GT4	GT5	7200
LH6 Diesel 6.2 Liter V8 (379 Cu In) (Reqs B3J)	MM4		MX0		GQ1	GT4	—	7200
			MX0		GQ1	GT4	GT5	7200

**CALIFORNIA ONLY
C/K2500 SERIES**

ENGINE	TRANSMISSION			AXLES			GVWR	
	4-SP	5-SP	AUTO	3.42	3.73	4.10		
W/YF5 CALIFORNIA EMISSION REQUIREMENTS								
-C20903-C20953-K20903-K20953								
LB4 V6 4.3 Liter (262 Cu In)-EFI	MM4	* MM5			GQ1	%GT4	—	7200
			MX0		GQ1	%GT4	%GT5	7200
L03 V8 5.0 Liter (305 Cu In)-EFI			MX0		GQ1	GT4	GT5	7200
L05 V8 5.7 Liter (350 Cu In)-EFI			MX0		GQ1	GT4	GT5	7200

%Reqs KC4 Eng Oil Cooler
* Standard Transmission

PRELIMINARY INFORMATION—SUBJECT TO CHANGE

**C/K PICKUP
POWER TEAMS
ALL STATES
C/K3500 SERIES**

POWER TEAMS (MUST ORDER ENGINE, TRANSMISSION AND REAR AXLE)
(Consult GVWR Selector and Tire Chart to insure tire capacity and availability)

ENGINE	TRANSMISSION		AXLES				GVWR	
	4-SP	AUTO	3.42	3.73	4.10	4.56		
W/NA5 STANDARD, NA6 HIGH ALTITUDE OR YF5 CALIFORNIA EMISSIONS								
-C30903-C30953								
L05 V8 5.7 Liter (350 Cu In)-EFI	MM4			GQ1	GT4	GT5	—	8600
		MX1		—	GQ1	GT5	\$HC4	8600
#L19 V8 7.4 Liter (454 Cu In)-EFI	MM4	MX1		GQ1	GT4	\$GT5	—	#10000
	MM4	%MX1		—	GQ1	\$GT5	\$HC4	#10000
LL4 Diesel 6.2 Liter V8 (379 Cu In)(Reqs B3J)	MM4			—	GQ1	GT5	—	8600
		MX1		—	GQ1	GT5	HC4	8600
MM4	%MX1		—	—	GQ1	HC4	#10000	
-K30903-K30953								
L05 5.7 Liter (350 Cu In)-EFI	MM4			GQ1	GT4	GT5	—	8600
		MX1		—	GQ1	GT5	\$HC4	8600
#L19 V8 7.4 Liter (454 Cu In)-EFI	MM4	MX1		GQ1	GT4	GT5	—	8600
LL4 Diesel 6.2 Liter V8 (379 Cu In)(Reqs B3J)	MM4			—	GQ1	GT5	—	8600
		MX1		—	GQ1	GT5	HC4	8600

\$Reqs KC4 Eng Oil Cooler
%Reqs V02 Cooler
#N/A G80 Locking Differential

**ENGINE RATINGS
ALL STATES**

SAE Net Ratings	▲4.3 Liter 262 EFI V6	▲5.0 Liter 305 EFI V8
Net Horsepower	160 @ 4000 rpm	170 @ 4000 rpm
Net Torque, lb-ft	235 @ 2400 rpm	255 @ 2400 rpm

SAE Net Ratings	▲5.7 Liter 350 EFI V8	■5.7 liter 350 EFI V8	■7.4 Liter 454 EFI V8
Net Horsepower	210 @ 4000 rpm	185 @ 4000 rpm	230 @ 3600 rpm
Net Torque, lb-ft	300 @ 2800 rpm	295 @ 2400 rpm	385 @ 1600 rpm

SAE Net Ratings	▲6.2 Liter 379 V8 Diesel	■6.2 Liter 379 V8 Diesel
Net Horsepower	†126 @ 3600 rpm	143 @ 3600 rpm
Net Torque, lb-ft	†240 @ 2000 rpm	247 @ 2000 rpm

▲For models with a GVWR up to 8500 lbs.
■For models with a GVWR from 8501 lbs. to 10,000 lbs.
† When Automatic Transmission is ordered, ratings are:
Net Horsepower 140 @ 3600
Net Torque, lb.-ft. 247 @ 2000

PRELIMINARY INFORMATION—SUBJECT TO CHANGE

C/K PICKUP

GVWR SELECTOR—ALL STATES

GVWR Rating (lbs)	†GAWR (lbs)		Minimum Equipment Required for GVW Rating			
	Front	Rear	Tire Capacity (lbs ea)		Chassis Equipment	
			Front	Rear		
C1500 SERIES REGULAR CAB						
5200	2904	2904	1452	1452	Standard	
5600	2950	3406	1703	1703		
C1500 SERIES EXTENDED CAB						
6000	3600	3686	1843	1843	Standard	
K1500 SERIES REGULAR CAB						
5600	*3350	3750	1930	1930	Standard	
K1500 SERIES EXTENDED CAB						
6200	3860	3750	2205	2205	Standard	

†GAWR's shown are the maximum for each axle with equipment listed. Other GAWR's are available, and they are determined as the minimum capacity of either axle, springs or tires.
 *3450 for K10903 model.

FRONT AND REAR TIRE AVAILABILITY CHART—ALL STATES

C/K 1500 SERIES

**Spare tire to match either front or rear tires must be ordered
 K1500 models require matching front and rear tread**

Description	Capacity (lbs ea)	Highway		On-Off Road		Spare
		Front	Rear	★Front	Rear	
TUBELESS STEEL BELTED RADIAL						
#P205/75R15	1452	XCE	YCE	—	—	ZCE
#P205/75R15 White Stripe	1452	XCG	YCG	—	—	ZCG
#P225/75R15	1703	XET	YET	—	—	ZET
#P225/75R15 White Stripe	1703	XEU	YEU	—	—	ZEU
#P225/75R15 White Lettered	1703	XEV	YEV	—	—	ZEV
#P235/75R15	1843	XFL	YFL	—	—	ZFL
#P235/75R15 White Stripe	1843	XFM	YFM	—	—	ZFM
#P235/75R15 White Letter	1843	XFN	YFN	—	—	ZFN
★LT225/75R16C	1930	XHE	YHE	—	—	ZHE
★LT225/75R16C White Outline Letter	1930	—	—	XHN	YHN	ZHN
★LT225/75R16C	1930	—	—	XHJ	YHJ	ZHJ
★LT225/75R16C White Stripe	1930	XHV	YHV	—	—	ZHV
•LT245/75R16C	2205	XBK	YBK	—	—	ZBK
•LT245/75R16C White Stripe	2205	XBL	YBL	—	—	ZBL
•LT245/75R16C	2205	—	—	XBN	YBN	ZBN
•LT245/75R16C White Letter	2205	—	—	XBX	YBX	ZBX
◆LT265/75R16C	2470	—	—	XGL	YGL	ZGL
◆LT265/75R16C White Outline Letter	2470	—	—	XGM	YGM	ZGM

- # Available on C1500 models only.
- ★ Available on K1500 models only.
- Available on K1500 Extended Cab models only.
- ◆ Available on K1500 models only. Requires Aluminum Wheels.

PRELIMINARY INFORMATION—SUBJECT TO CHANGE

C/K PICKUP

GVWR SELECTOR—ALL STATES

GVWR Rating (lbs)	†GAWR (lbs)		Minimum Equipment Required for GVW Rating			
	Front	Rear	Tire Capacity (lbs ea)		Chassis Equipment	
			Front	Rear		
C2500 SERIES REGULAR CAB						
7200	▲3150	4670	2335	2335	Standard	
C2500 SERIES EXTENDED CAB						
7200	3600	4670	2335	2335	Standard	
K2500 SERIES REGULAR CAB						
7200	3925	4670	2335	2335	Standard	
K2500 SERIES EXTENDED CAB						
7200	3925	4410	2205	2205	Standard	

†GAWR's shown are the maximum for each axle with equipment listed. Other GAWR's are available, and they are determined as the minimum capacity of either axle, springs or tires.

▲Rated 3400 lbs. for diesel engine models.

FRONT AND REAR TIRE AVAILABILITY CHART—ALL STATES

C/K2500 SERIES

**Spare tire to match either front or rear tires is available at extra cost
K2500 models require matching front and rear tread**

Description	Capacity (lbs ea)	Highway		On-Off Road		Spare
		Front	Rear	*Front	Rear	
TUBELESS STEEL BELTED RADIAL						
#LT225/75R16D	2335	XHP	YHP	—	—	ZHP ZHR
#LT225/75R15D White Stripe	2335	XHQ	YHQ	—	—	ZHQ
★LT225/75R16D	2335	—	—	XHR	YHR	ZHR
▲LT245/75R16C	2205	XBK	YBK	—	—	ZBK
▲LT245/75R16C White Stripe	2205	XBL	YBL	—	—	ZBL
▲LT245/75R16C	2205	—	—	XBN	YBN	ZBN
▲LT245/75R16C White Outline Letter	2205	—	—	XBX	YBX	ZBX
#LT245/75R16E	3000	XHH	YHH	—	—	ZHH ZGK
★LT245/75R16E	3000	—	—	—	YGK	ZGK
★LT245/75R16E	3000	—	—	XGK	YGK	ZGK

#Not available on K20953 Extended Cab models.

★Available on K20903 Regular Cab models only.

▲Available on K20953 Extended Cab models only.

PRELIMINARY INFORMATION—SUBJECT TO CHANGE

C/K PICKUP

GVWR SELECTOR—ALL STATES

GVW Rating (lbs)	†GAWR (lbs)		Minimum Equipment Required for GVW Rating		
	Front	Rear	Tire Capacity (lbs ea)		Chassis Equipment
			Front	Rear	

C3500 SERIES REGULAR CAB

8600	3800	6000	3000	3000	Standard
10,000	3800	7500	1930	1875 (Duals)	Dual Rear Wheel Provisions (R05)

C3500 SERIES EXTENDED CAB

8600	3800	6000	3000	3000	Standard
10,000	3800	7500	1930	1875 (Duals)	Dual Rear Wheel Provisions (R05)

K3500 SERIES REGULAR CAB

8600	4250	6000	3000	3000	Standard
-------------	------	------	------	------	----------

K3500 SERIES EXTENDED CAB

8600	4250	6000	3000	3000	Standard
-------------	------	------	------	------	----------

†GAWR's shown are the maximum for each axle with equipment listed. Other GAWR's are available, and they are determined as the minimum capacity of either axle, springs or tires.

FRONT AND REAR TIRE AVAILABILITY CHART—ALL STATES

C/K3500 SERIES

**Spare tire to match either front or rear tires is available at extra cost
K3500 models require matching front and rear tread**

Description	Capacity (lbs each)		Highway			On-Off Road			Spare
	Front/ Single Rear	Dual Rear	Front	Single Rear	Dual Rear	†Front	Single Rear	Dual Rear	
TUBELESS Steel Belted Radial									
#LT225/75R16C	1930	—	XHE	—	—	—	—	—	—
LT225/75R16D	—	1875	—	—	YHP	—	—	YHR	ZHP ZHR
#LT225/75R16D	2335	1875	XHP	—	YHP	—	—	—	ZHP ZHR
#LT225/75R16D White Stripe	2335	1875	XHQ	—	YHQ	—	—	—	ZHQ
#LT225/75R16C White Stripe	1930	—	XHV	—	—	—	—	—	—
#LT225/75R16D White Stripe	—	1875	—	—	YHQ	—	—	—	ZHQ
†LT245/75R16E	3000	3000	—	—	—	XGK	YGK	—	ZGK
LT245/75R16E	3000	3000	XHH	YHH	—	—	—	—	ZHH ZGK
#LT245/75R16E	—	—	XHH	—	—	—	YGK	—	—
TUBE-TYPE Nylon									
#7.50-16D	2440	2140	XPF	—	YPF	—	—	—	ZPF

#Available on C3500 models only

†Available on K3500 models only

PRELIMINARY INFORMATION—SUBJECT TO CHANGE

NOTES

C/K PICKUP

THE FOLLOWING EQUIPMENT IS STANDARD ON DIESEL ENGINE MODELS (ALSO SEE STANDARD SPECIFICATIONS PAGES)

- Low Coolant Sensor
- Poly-wrapped Paper Element Air Cleaner
- Engine Block Heater (600 watts, 120 volts)
- Water/fuel separator unit which incorporates a water sensor and sending unit, a fuel filter, a fuel heater and drain capability
- Hydraulic Power-assisted Brakes
- Engine Oil Cooler
- Dual 540 Cold Cranking Amp/115 min. Reserve Capacity Batteries
- HD Radiator
- Single Exhaust System
- Additional Insulation:
 - Cab-to-fender insulators
 - Fiberglass hood insulator
 - Fiberglass engine compartment firewall insulator
 - Cowl side spray-on deadener
 - Driver compartment dash mat with increased mastic layer
 - Resinated cotton and mastic floor insulation
 - Full cowl interior trim panels with resinated cotton insulation
 - Vinyl-coated rubber floor mat for regular cab models
- Warning Lights: Glow Plugs, Water-in-fuel (or fuel filter), and Low Coolant
- Diesel Engine Identification:
 - "Diesel Fuel Only" label inside fuel filler door

PRELIMINARY INFORMATION—SUBJECT TO CHANGE

C-K PICKUP

2-WHEEL DRIVE (5200-lb - 10,000-lb GVW)

4-WHEEL DRIVE (5600-lb - 8600-lb GVW)

1988 VEHICLES WITH STANDARD EQUIPMENT

Prices shown are effective with initial shipments of 1988 model motor vehicles

Description	Model Number	Body Code	Wheel Base	Factory D&H(a)	List Price	Mfr's Suggested Retail Price*	Group Number
<i>(All models have regular cab unless otherwise indicated)</i>							
◆ 6-Cylinder 4.3 Liter (262 Cu. In.) E.F.I. V6 Gasoline Engine-Engine Ordering Code LB4							
C1500 Series 2-Wheel Drive							
Fleetside (6 1/2-ft) .	CC10703	E63	117.5"	N.A.	9347.00	9347.00	19
Fleetside (8-ft)	CC10903	E63	131.5"	N.A.	9531.00	9531.00	19
Extended Cab							
Fleetside (8-ft) . .	CC10953	E63	155.5"	N.A.	10722.00	10722.00	19
C2500 Series 2-Wheel Drive							
Fleetside (8-ft)	CC20903	E63	131.5"	N.A.	10384.00	10384.00	19
Extended Cab							
Fleetside (8-ft) . .	CC20953	E63	155.5"	N.A.	11684.00	11684.00	19
K1500 Series 4-Wheel Drive							
Fleetside (6 1/2-ft) .	CK10703	E63	117.5"	N.A.	11587.00	11587.00	19
Fleetside (8-ft)	CK10903	E63	131.5"	N.A.	11774.00	11774.00	19
Extended Cab							
Fleetside (8-ft) . .	CK10953	E63	155.5"	N.A.	12864.00	12864.00	19
K2500 Series 4-Wheel Drive							
Fleetside (8-ft)	CK20903	E63	131.5"	N.A.	11840.00	11840.00	19
Extended Cab							
Fleetside (8-ft) . .	CK20953	E63	155.5"	N.A.	13007.00	13007.00	19
◆ 8-Cylinder 5.7 Liter (350 Cu. In.) E.F.I. V8 Gasoline Engine-Engine Ordering Code L05							
C3500 Series 2-Wheel Drive							
Fleetside (8-ft)	CC30903	E63	131.5"	N.A.	11405.00	11405.00	19
Extended Cab							
Fleetside (8-ft) . .	CC30953	E63	155.5"	N.A.	12563.00	12563.00	19
K3500 Series 4-Wheel Drive							
Fleetside (8-ft)	CK30903	E63	131.5"	N.A.	13352.00	13352.00	19
Extended Cab							
Fleetside (8-ft) . .	CK30953	E63	155.5"	N.A.	14352.00	14352.00	19
◆ 8-Cylinder 6.2 Liter (379 Cu. In.) L.D. Diesel V8 Engine-Engine Ordering Code LH6							
C2500 Series 2-Wheel Drive							
Fleetside (8-ft)	CC20903	E63 & B3J	131.5"	N.A.	12569.00	12569.00	19
Extended Cab							
Fleetside (8-ft) . .	CC20953	E63 & B3J	155.5"	N.A.	13869.00	13869.00	19
K2500 Series 4-Wheel Drive							
Fleetside (8-ft)	CK20903	E63 & B3J	131.5"	N.A.	14443.00	14443.00	19
Extended Cab							
Fleetside (8-ft) . .	CK20953	E63 & B3J	155.5"	N.A.	15340.00	15340.00	19
◆ 8-Cylinder 6.2 Liter (379 Cu. In.) H.D. Diesel V8 Engine-Engine Ordering Code LL4							
C3500 Series 2-Wheel Drive							
Fleetside (8-ft)	CC30903	E63 & B3J	131.5"	N.A.	12803.00	12803.00	19
Extended Cab							
Fleetside (8-ft) . .	CC30953	E63 & B3J	155.5"	N.A.	14028.00	14028.00	19
K3500 Series 4-Wheel Drive							
Fleetside (8-ft)	CK30903	E63 & B3J	131.5"	N.A.	14515.00	14515.00	19
Extended Cab							
Fleetside (8-ft) . .	CK30953	E63 & B3J	155.5"	N.A.	15515.00	15515.00	19

- ★ Manufacturer's Suggested Retail Prices do not include applicable destination charges, state and local taxes, license fees, optional equipment or special items or services.
- ◆ Refer to Dealer Order Guide for California Requirements.

(a) D & H Charges on vehicle and optional equipment include reimbursement to ordering Division for any tax that it has paid, incurred or agreed to pay thereon.

C-K PICKUP

OPTIONS WHEN INSTALLED BY GENERAL MOTORS

Prices shown are effective with initial shipments of 1988 model motor vehicles

Description	Option Number	Factory D&H(a)	List Price	Mfr's Suggested Retail Price ◇
Scottsdale/Sierra SLX: (See Interior and Exterior Color Selection Charts) Includes VG3 Bumper with rub strip and rubber color-keyed floor covering.				
C-K1,2 Regular Cab only. Also includes B84 Black Body Side and B74 Wheel Opening Moldings	Z62	N.A.	353.00	353.00
C-K1,2 Extended Cab only. Also includes B84 Black Body Side and B74 Wheel Opening Moldings	Z62	N.A.	263.00	263.00
C3 Regular Cab only				
Without R05 Dual Rear Wheels. Also includes B84 Black Body Side and B74 Wheel Opening Moldings	Z62	N.A.	353.00	353.00
With R05 Dual Rear Wheels	Z62	N.A.	248.00	248.00
C3 Extended Cab only				
Without R05 Dual Rear Wheels. Also includes B84 Black Body Side and B74 Wheel Opening Moldings	Z62	N.A.	263.00	263.00
With R05 Dual Rear Wheels	Z62	N.A.	158.00	158.00
K3 Regular Cab. Also includes B84 Black Body Side Moldings	Z62	N.A.	322.00	322.00
K3 Extended Cab only. Also includes B84 Black Body Side Moldings	Z62	N.A.	232.00	232.00
Silverado/Sierra SLE: Available only when custom cloth or custom vinyl seats are specified. Includes color-keyed carpeting for front seat area, cab back insulation, visor mirror, V22 Deluxe Front Appearance, VG3 Bumper with rub strip, U37 Cigarette Lighter and N31 Custom Steering Wheel.				
C-K1,2 Regular Cab only. Also includes B85 Bright Body Side Moldings and B96 Bright Wheel Opening Moldings.	YE9	N.A.	681.00	681.00
C-K1,2 Extended Cab only. Also includes B85 Bright Body Side Moldings and B96 Bright Wheel Opening Moldings and rear seat area carpeting	YE9	N.A.	611.00	611.00
C3 Regular Cab only				
Without R05 Dual Rear Wheels. Also includes B85 Bright Body Side Moldings and B96 Bright Wheel Opening Moldings	YE9	N.A.	681.00	681.00
With R05 Dual Rear Wheels	YE9	N.A.	524.00	524.00
C3 Extended Cab only. Also includes rear seat area carpeting				
Without R05 Dual Rear Wheels. Also includes B85 Bright Body Side Moldings and B96 Bright Wheel Opening Moldings	YE9	N.A.	611.00	611.00
With R05 Dual Rear Wheels	YE9	N.A.	454.00	454.00
K3 Regular Cab only. Also includes B85 Bright Body Side Moldings	YE9	N.A.	650.00	650.00
K3 Extended Cab only. Also includes B85 Bright Body Side Moldings and rear seat area carpeting	YE9	N.A.	580.00	580.00
Seat Trim: (See Interior and Exterior Color Selection Chart for availability and ordering information).				
V**1 Vinyl Bench	...	NO ADDITIONAL CHARGE		
V**3 Vinyl Split Bench. Extended Cab only. Not available when YE9 or Z62 is specified. Available only when AM7 Folding Rear Seat is specified	...	N.A.	125.00	125.00
C**1 Cloth Bench. Regular Cab only. Not available when YE9 is specified	...	NO ADDITIONAL CHARGE		
Without Z62	...	NO ADDITIONAL CHARGE		
With Z62	...	NO ADDITIONAL CHARGE		
L**1 Custom Cloth Bench. Regular Cab only. Available only when YE9 is specified	...	NO ADDITIONAL CHARGE		
L**3 Custom Cloth Split Bench Seat. Extended Cab only. Available only when YE9 and AM7 Folding Rear Seat are specified	...	N.A.	125.00	125.00
L**2 Custom Cloth Bucket Seat. Available only when YE9 and AM7 Folding Rear Seat are specified	...			
Regular Cab only	...	N.A.	100.00	100.00
Extended Cab only	...	N.A.	125.00	125.00

(a) D & H Charges on vehicle and optional equipment include reimbursement to ordering Division for any tax that it has paid, incurred or agreed to pay thereon.
 ◇ State and local taxes not included.

C-K PICKUP

OPTIONS WHEN INSTALLED BY GENERAL MOTORS

Prices shown are effective with initial shipments of 1988 model motor vehicles

Description	Option Number	Factory D&H(a)	List Price	Mfr's Suggested Retail Price ◇
Seat Trim: (Continued)				
<i>X**3 Custom Vinyl Split Bench Seat. Extended Cab only. Available only when AM7 Folding Rear Seat and YE9 or Z62 is specified</i>				
With Z62	N.A.	125.00	125.00
With YE9	N.A.	125.00	125.00
<i>X**2 Custom Vinyl Bucket Seat Available only when AM7 Folding Rear Seat and Z62 or YE9 is specified</i>				
<i>Regular Cab only.</i>				
With Z62	N.A.	152.00	152.00
With YE9	N.A.	100.00	100.00
<i>Extended Cab only</i>				
With Z62	N.A.	125.00	125.00
With YE9	N.A.	125.00	125.00
<i>X**1 Custom Vinyl Bench Seat. Available only when YE9 or Z62 is specified</i>				
<i>Regular Cab only.</i>				
With Z62	N.A.	52.00	52.00
With YE9	NO ADDITIONAL CHARGE		
<i>Extended Cab only.</i>				
With Z62	NO ADDITIONAL CHARGE		
With YE9	NO ADDITIONAL CHARGE		
Paints, Exterior: (See Interior and Exterior Color Selection Chart for ordering information and paint application).				
<i>Solid</i>	ZY1	NO ADDITIONAL CHARGE		
<i>Conventional Two-Tone.</i>	ZY2	N.A.	132.00	132.00
<i>Special Two-Tone.</i>	ZY3	N.A.	215.00	215.00
<i>Deluxe Two-Tone.</i>	ZY4	N.A.	243.00	243.00
Emission Systems: Dealer Note - One of the following emission options must be specified. (See Power Teams Chart for availability and complete specifications).				
<i>California Emission Requirements. Includes all testing, equipment and/or certification necessary for registration in the State of California. Not available when NA6 High Altitude Emissions or LH6 6.2 Diesel Engine are specified.</i>				
.....	YF5	N.A.	99.00	99.00
<i>High Altitude Emission Equipment. Not available when NA5 Standard or YF5 California Emissions is specified.</i>				
.....	NA6	NO ADDITIONAL CHARGE		
<i>Standard Emission Equipment. Not available when NA6 High Altitude or YF5 California Emissions are specified.</i>				
.....	NA5	NO ADDITIONAL CHARGE		
Engines: (See Power Teams Chart for availability and complete specifications).				
<i>Gasoline.</i>				
<i>4.3 Liter (262 Cu. In.) E.F.I. V6. Standard on C-K1,2 Series only</i>				
.....	LB4	NO ADDITIONAL CHARGE		
<i>5.0 Liter (305 Cu. In.) E.F.I. V8. Available on C-K1,2 Series only.</i>				
.....	L03	N.A.	495.00	495.00
<i>5.7 Liter (350 Cu. In.) E.F.I. V8. Standard on C-K3 Series ..</i>				
.....	L05	N.A.	740.00	740.00
<i>7.4 Liter (454 Cu. In.) E.F.I. V8. C-K3 Series only.</i>				
.....	L19	N.A.	385.00	385.00
<i>Diesel.</i>				
<i>6.2 Liter (379 Cu. In.) L.D. V8 Diesel. C-K2 Series only. Not available when YF5 California Emission Requirements is specified. Available only when B3J Diesel Equipment is specified.</i>				
.....	LH6	NO ADDITIONAL CHARGE		
<i>6.2 Liter (379 Cu. In.) H.D. V8 Diesel. C-K-3 Series only. Available only when B3J Diesel Equipment is specified.</i>				
.....	LL4	NO ADDITIONAL CHARGE		
Transmissions: (See Power Teams Chart for availability and complete specifications).				
<i>3-Speed Automatic.</i>				
<i>C-K1,2 Series only. Not available when YF5 California Emissions is specified. Available only when L03 5.0 Liter or LB4 4.3 Liter Engine is specified.</i>				
.....	MX1	N.A.	565.00	565.00
<i>C-K3 Series only</i>				
.....	MX1	N.A.	565.00	565.00

(a) D & H Charges on vehicle and optional equipment include reimbursement to ordering Division for any tax that it has paid, incurred or agreed to pay thereon.
 ◇ State and local taxes not included.

C-K PICKUP

OPTIONS WHEN INSTALLED BY GENERAL MOTORS

Prices shown are effective with initial shipments of 1988 model motor vehicles

Description	Option Number	Factory D&H(a)	List Price	Mfr's Suggested Retail Price◇
Transmissions: (Continued)				
<i>4-Speed Manual. H.D. With Creeper Low. Standard on C-K2 Series when B3J Diesel Equipment is specified. Standard on C-K3 Series. Not available on C10703.</i>				
C1 Series only	MM4	N.A.	98.00	98.00
K1 and C-K2 Series only	MM4	N.A.	98.00	98.00
<i>4-Speed Manual. Standard on C1 Series</i>	MC0	NO ADDITIONAL CHARGE		
<i>5-Speed Manual with Overdrive. Standard on K1,C-K2 Series</i>	MM5	N.A.	185.00	185.00
<i>4-Speed Automatic with Overdrive. C-K1-2 Series only.</i>	MX0	N.A.	735.00	735.00
Axles, Rear: (See Power Teams Chart for option number selection, availability and complete specifications)				
<i>Optional Ratio</i>	...	N.A.	38.00	38.00
<i>Locking Differential</i>	G80	N.A.	252.00	252.00
Tires: (See Tire Charts for Tire Availability)				
<i>Spare tire carrier included when spare tire is specified on C-K-2,3 series</i>				
<i>All rim sizes are 6.00" except when N90 or PA6 Wheels are specified on C1 Series.</i>				
<i>All rim sizes are 6.50" on C-K2 Series or C-K3 Series without R05 Dual Rear Wheels and K1 Series except with PF4 Wheels</i>				
<i>All rim sizes are 6.00" on C3 Series with R05 Dual Rear Wheels.</i>				
Dealer Note: When dual rear tires are specified, R05 Dual Rear Wheels will be applied to the order.				
THIS EQUIPMENT IS NOT PRICED IN THE TIRE OPTION AND WILL BE REFLECTED ON THE INVOICE SEPARATELY.				
For complete specifications and ordering information, see "OTHER OPTIONS" Section.				
TUBELESS				
<i>P205/75R15 All Seasons Steel Belted Radial Ply Blackwall (Maximum Capacity 1452-lbs)</i>				
C1 Series only.				
Front	XCE	NO ADDITIONAL CHARGE		
Rear	YCE	NO ADDITIONAL CHARGE		
Spare	ZCE	NO ADDITIONAL CHARGE		
<i>P205/75R15 All Seasons Steel Belted Radial Ply Whitewall (Maximum Capacity 1452-lbs)</i>				
C1 Series only.				
Front	XCG	N.C.	28.00	28.00
Rear	YCG	N.C.	28.00	28.00
Spare	ZCG	N.C.	14.00	14.00
<i>P225/75 R15 All Seasons Steel Belted Radial Ply White Lettered (Maximum Capacity 1703-lbs)</i>				
C1 Series only				
Front	XEV	N.C.	100.00	100.00
Rear	YEV	N.C.	100.00	100.00
Spare	ZEV	N.C.	50.00	50.00
<i>P225/75R15 All Seasons Steel Belted Radial Ply Blackwall (Maximum Capacity 1703-lbs)</i>				
C1 Series only				
Front	XET	N.C.	50.00	50.00
Rear	YET	N.C.	50.00	50.00
Spare	ZET	N.C.	25.00	25.00
<i>P225/75R15 All Seasons Steel Belted Radial Ply Whitewall (Maximum Capacity 1703-lbs)</i>				
C1 Series only				
Front	XEU	N.C.	86.00	86.00
Rear	YEU	N.C.	86.00	86.00
Spare	ZEU	N.C.	43.00	43.00
<i>P235/75R15 All Seasons Steel Belted Radial Ply Blackwall (Maximum Capacity 1843-lbs). Standard on C1 Extended Cab</i>				
C1 Regular Cab only				
Front	XFL	N.C.	78.00	78.00
Rear	YFL	N.C.	78.00	78.00
Spare	ZFL	N.C.	39.00	39.00

(a) D & H Charges on vehicle and optional equipment include reimbursement to ordering Division for any tax that it has paid, incurred or agreed to pay thereon.
 ◇ State and local taxes not included.

C-K PICKUP

OPTIONS WHEN INSTALLED BY GENERAL MOTORS

Prices shown are effective with initial shipments of 1988 model motor vehicles

Description	Option Number	Factory D&H(a)	List Price	Mfr's Suggested Retail Price◇
P235/75R15 All Seasons Steel Belted Radial Ply Whitewall (Maximum Capacity 1843-lbs.)				
Front				
C1 Regular Cab only	XFM	N.C.	114.00	114.00
C1 Extended Cab only	XFM	N.C.	36.00	36.00
Rear				
C1 Regular Cab only	YFM	N.C.	114.00	114.00
C1 Extended Cab only	YFM	N.C.	36.00	36.00
Spare				
C1 Regular Cab only	ZFM	N.C.	57.00	57.00
C1 Extended Cab only	ZFM	N.C.	18.00	18.00
P235/75 R15 All Seasons Steel Belted Radial Ply White Lettered (Maximum Capacity 1843-lbs.)				
Front				
C1 Regular Cab only	XFN	N.C.	128.00	128.00
C1 Extended Cab only	XFN	N.C.	50.00	50.00
Rear				
C1 Regular Cab only	YFN	N.C.	128.00	128.00
C1 Extended Cab only	YFN	N.C.	50.00	50.00
Spare				
C1 Regular Cab only	ZFN	N.C.	64.00	64.00
C1 Extended Cab only	ZFN	N.C.	25.00	25.00
LT225/75R16C All Seasons Steel Belted Radial Ply Blackwall (Maximum Capacity 1930-lbs). Standard on K1 Regular Cab				
Front				
K1 Series only	XHE	NO ADDITIONAL CHARGE		
C3 Series with R05 Dual Rear Wheels	XHE	N.C.	(-102.00)	(-102.00)
Rear				
.....	YHE	NO ADDITIONAL CHARGE		
Spare				
.....	ZHE	NO ADDITIONAL CHARGE		
LT225/75R16C All Seasons Steel Belted Radial Ply Whitewall (Maximum Capacity 1930-lbs.)				
K1 Series only.				
Front	XHV	N.C.	36.00	36.00
Rear	YHV	N.C.	36.00	36.00
Spare	ZHV	N.C.	18.00	18.00
LT225/75R16C On-Off Road Steel Belted Radial Ply Blackwall (Maximum Capacity 1930-lbs.)				
K1 Series only.				
Front	XHJ	N.C.	22.00	22.00
Rear	YHJ	N.C.	22.00	22.00
Spare	ZHJ	N.C.	11.00	11.00
LT225/75R16C On-Off Road Steel Belted Radial Ply White Outline Lettered (Maximum Capacity 1930-lbs.)				
K1 Series only				
Front	XHN	N.C.	72.00	72.00
Rear	YHN	N.C.	72.00	72.00
Spare	ZHN	N.C.	36.00	36.00
LT225/75R16D All Seasons Steel Belted Radial Ply Blackwall (Maximum Capacity each. Front 2335-lbs) (Dual Rear 1875-lbs)				
Front. Standard on C2 Series or K2 Regular Cab. C3 Series with R05 Dual Rear Wheels	XHP	N.C.	(-68.00)	(-68.00)
Rear. Standard on C2 Series or K2 Regular Cab. C3 Series with R05 Dual Rear Wheels	YHP	N.C.	430.00	430.00
Spare				
K2 Regular Cab and C2 Series	ZHP	N.C.	289.00	289.00
C3 Series with R05 Dual Rear Wheels	ZHP	N.C.	300.00	300.00
LT225/75R16D All Seasons Steel Belted Radial Ply Whitewall (Maximum Capacity 2335-lbs) (Dual Rear 1895-lbs)				
Front. K2 Regular Cab and C2 Series	XHQ	N.C.	36.00	36.00
Rear. K2 Regular Cab and C2 Series	YHQ	N.C.	36.00	36.00
Spare. K2 Regular Cab and C2 Series	ZHQ	N.C.	307.00	307.00

(a) D & H Charges on vehicle and optional equipment include reimbursement to ordering Division for any tax that it has paid, incurred or agreed to pay thereon.

◇ State and local taxes not included.

C-K PICKUP

OPTIONS WHEN INSTALLED BY GENERAL MOTORS

Prices shown are effective with initial shipments of 1988 model motor vehicles

Description	Option Number	Factory D&H(a)	List Price	Mfr's Suggested Retail Price◇
LT225/75R16D On Off Road Steel Belted Radial Ply Blackwall (Maximum Capacity 2335-lbs) (Dual Rear 1875-lbs)				
Front. K2 Regular Cab only	XHR	N.C.	22.00	22.00
Rear.				
K2 Regular Cab and C2 Series	YHR	N.C.	22.00	22.00
C3 Series with R05 Dual Rear Wheels	YHR	N.C.	474.00	474.00
Spare.				
K2 Regular Cab and C2 Series	ZHR	N.C.	300.00	300.00
C3 Series with R05 Dual Rear Wheels	ZHR	N.C.	311.00	311.00
LT245/75R16C All Seasons Steel Belted Radial Ply Blackwall (Maximum Capacity 3000-lbs)				
Front. Standard on K1-2 Extended Cab	XBK	NO ADDITIONAL CHARGE		
Rear. Standard on K1-2 Extended Cab	YBK	NO ADDITIONAL CHARGE		
Spare.				
K1 Extended Cab only. Standard	ZBK	NO ADDITIONAL CHARGE		
K2 Extended Cab only	ZBK	N.C.	300.00	300.00
LT 245/75 R16C All Seasons Steel Belted Radial Ply Whitewall (Maximum Capacity 2205-lbs)				
K1-2 Extended Cab only				
Front	XBL	N.C.	34.00	34.00
Rear	YBL	N.C.	34.00	34.00
Spare				
K1 Extended Cab only	ZBL	N.C.	17.00	17.00
K2 Extended Cab only	ZBL	N.C.	317.00	317.00
LT 245/75 R16C On Off Road Steel Belted Radial Ply Blackwall (Maximum Capacity 2205-lbs)				
K1-2 Extended Cab only				
Front	XBN	N.C.	22.00	22.00
Rear	YBN	N.C.	22.00	22.00
Spare				
K1 Extended Cab only	ZBN	N.C.	11.00	11.00
K2 Extended Cab only	ZBN	N.C.	311.00	311.00
LT 245/75R16C On Off Road Steel Belted Radial Ply White Lettered (Maximum Capacity 2205-lbs)				
K1-2 Extended Cab only				
Front	XBX	N.C.	72.00	72.00
Rear	YBX	N.C.	72.00	72.00
Spare				
K1 Extended Cab only	ZBX	N.C.	36.00	36.00
K2 Extended Cab only	ZBX	N.C.	336.00	336.00
LT245/75R16E All Seasons Steel Belted Radial Ply Blackwall (Maximum Capacity 3000-lbs). Standard on C-K3 Series				
Front. K2 Regular Cab and C2 Series	XHH	N.C.	90.00	90.00
Rear. K2 Regular Cab and C2 Series	YHH	N.C.	90.00	90.00
Spare	ZHH	N.C.	334.00	334.00
LT245/75R16E On Off Road Steel Belted Radial Ply Blackwall (Maximum Capacity 3000-lbs)				
Front				
K2 Regular Cab only	XGK	N.C.	112.00	112.00
K3 Series only	XGK	N.C.	22.00	22.00
Rear				
K2 Regular Cab and C2 Series	YGK	N.C.	112.00	112.00
C-K3 Series only	YGK	N.C.	22.00	22.00
Spare				
K2 Regular Cab and C2 Series	ZGK	N.C.	345.00	345.00
C-K3 Series only	ZGK	N.C.	345.00	345.00
LT265/75R16C On Off Road Steel Belted Radial Ply Blackwall (Maximum Capacity 2470-lbs)				
K1 Series only				
Front				
K1 Regular Cab only	XGL	N.C.	132.00	132.00
K1 Extended Cab only	XGL	N.C.	76.00	76.00
Rear				
K1 Regular Cab only	YGL	N.C.	132.00	132.00
K1 Extended Cab only	YGL	N.C.	76.00	76.00
Spare				
K1 Regular Cab only	ZGL	N.C.	66.00	66.00
K1 Extended Cab only	ZGL	N.C.	38.00	38.00

(a) D & H Charges on vehicle and optional equipment include reimbursement to ordering Division for any tax that it has paid, incurred or agreed to pay thereon.

◇ State and local taxes not included.

C-K PICKUP

OPTIONS WHEN INSTALLED BY GENERAL MOTORS

Prices shown are effective with initial shipments of 1988 model motor vehicles

Description	Option Number	Factory D&H(a)	List Price	Mfr's Suggested Retail Price◇
<i>LT265/75R16C On Off Road Steel Belted Radial Ply White Outline Lettered</i>				
(Maximum Capacity 2470-lbs)				
K1 Series only				
Front				
K1 Regular Cab only	XGM	N.C.	182.00	182.00
K1 Extended Cab only	XGM	N.C.	126.00	126.00
Rear				
K1 Regular Cab only	YGM	N.C.	182.00	182.00
K1 Extended Cab only	YGM	N.C.	126.00	126.00
Spare				
K1 Regular Cab only	ZGM	N.C.	91.00	91.00
K1 Extended Cab only	ZGM	N.C.	63.00	63.00
Tube-Type				
<i>7.50-16D Nylon Blackwall</i>				
(Maximum Capacity each. Front 2440-lbs) (Dual Rear 2140-lbs.)				
C30 Series with R05 Dual Rear Wheels				
Front	XPF	N.C.	(-146.00)	(-146.00)
Rear	YPF	N.C.	274.00	274.00
Spare	ZPF	N.C.	261.00	261.00

OTHER OPTIONS

Air Cleaner, Pre-Cleaner:	K46	N.A.	44.00	44.00
Air Conditioning: <i>All-Weather.</i> C-K1,2 Series with LB4 4.3 Liter Engine available only when KC4 Engine Oil Cooler is specified. Not available when V10 Cold-Climate Package is specified. Includes extra cooling.	C60	N.A.	781.00	781.00
Appearance, Deluxe Front: Includes dark argent grille with bright trim and quad halogen headlamps. Included when YE9 is specified	V22	N.A.	145.00	145.00
Batteries: 12-Volt. Not available when B3J Diesel Equipment is specified.				
<i>Auxiliary.</i> 540 Cold Cranking Amps Delco Freedom. Included with Z81 Camper Special without B3J Diesel Equipment .	TP2	N.A.	134.00	134.00
<i>Heavy-Duty.</i> 630 Cold Cranking Amps Delco Freedom. Included when V10 Cold-Climate Package is specified ...	UA1	N.A.	56.00	56.00
Bumper Equipment:				
<i>Bumpers, Chromed.</i>				
Front, Deluxe with rub strip. Included with Z62 or YE9. ...	VG3	N.A.	26.00	26.00
Rear Step with rub strip. Available only when VG3 Front Bumper is specified	VB3	N.A.	229.00	229.00
<i>Bumpers, Painted.</i> Rear Step. Not available when B85 Bright Moldings or when YE9 is specified	V43	N.A.	130.00	130.00
<i>Guards, Front Bumper. Black</i> Available only when VG3 Deluxe Front Bumper is specified	V27	N.A.	32.00	32.00
Camper Special Chassis Equipment: Basic Camper Group. C-K2-3 Series only. Includes TP2 Auxiliary Battery without B3J Diesel Equipment. Also includes camper body wiring harness, DF2 Mirrors, F59 Stabilizer and NJ8 Fuel Tank				
Without B3J Diesel Equipment	Z81	N.A.	376.00	376.00
With B3J Diesel Equipment	Z81	N.A.	242.00	242.00
Carrier, Spare Wheel and Tire: Side Mounted.				
Available only when spare tire is specified. Not available on K10703 or when R05 Dual Rear Wheels are specified.	P13			
NO ADDITIONAL CHARGE				
Cold-Climate Package: Not available when C60 Air Conditioning or B3J Diesel Equipment is specified. Includes special insulation, C42 H.D. Heater and Defroster, K05 Engine Block Heater and anti-freeze protection to -32 degrees				
Without L19 7.4 Liter Engine. Also includes UA1 H.D. Battery	V10	N.A.	134.00	134.00
With L19 7.4 Liter Engine	V10	N.A.	78.00	78.00

(a) D & H Charges on vehicle and optional equipment include reimbursement to ordering Division for any tax that it has paid, incurred or agreed to pay thereon.

◇ State and local taxes not included.

C-K PICKUP

OPTIONS WHEN INSTALLED BY GENERAL MOTORS

Prices shown are effective with initial shipments of 1988 model motor vehicles

Description	Option Number	Factory D&H(a)	List Price	Mfr's Suggested Retail Price◇
OTHER OPTIONS				
Console: Available only when bucket seats are specified .	D55	N.A.	114.00	114.00
Cooling Systems:				
<i>Engine Oil.</i> Not available when B3J Diesel Equipment is specified. C-K1-2 Series with MX1 or MX0 Automatic Transmission available only when V02 Radiator and Transmission Oil Cooler is specified. C-K3 Series with L19 7.4 Liter or L05 5.7 Liter Engine, available only when V02 Radiator and Transmission Oil Cooler is specified. Included with Z82 Trailing Special	KC4	N.A.	126.00	126.00
<i>Radiator, Heavy-Duty.</i> Not available when C60 Air Conditioning or V02 Radiator and Transmission Oil Cooler is specified.	V01	N.A.	56.00	56.00
<i>Radiator and Transmission Oil, Heavy-Duty.</i> Not available when V01 H.D. Radiator is specified. Available only when MX1 or MX0 Automatic Transmission is specified. Included when Z82 Trailing Special or R05 Dual Rear Wheels are specified	V02	N.A.	63.00	63.00
Defogger, Rear Window: Electric. Not available when A28 Sliding Rear Window is specified. Available only when YE9 or Z62 is specified. Regular Cab also available only when A01 Tinted Glass is specified	C49	N.A.	154.00	154.00
Filler Cap, Fuel: Locking	N05	N.A.	18.00	18.00
Floor Covering: Mats, Color-Keyed.				
<i>Front Floor. Removable.</i> Available only when YE9 is specified	B32	N.A.	16.00	16.00
<i>Rear. Extended Cab only.</i> Available only when AM7 Folding Rear Seat and B32 Front Floor Mats are specified	B33	N.A.	12.00	12.00
Gages: Voltmeter, Temperature and Oil Pressure.	Z53	N.A.	42.00	42.00
Glass:				
<i>Tinted.</i> All Windows. Standard on Extended Cab	A01	N.A.	48.00	48.00
<i>Deep Tinted with light tinted rear window.</i> Extended Cab only. Not available when AJ1 Deep Tinted Glass is specified. Includes A20 Swing-Out Quarter Windows	AA3	N.A.	98.00	98.00
<i>Deep Tinted.</i> Extended Cab only. Not available when A28 Sliding Rear Windows or C49 Defogger is specified. Includes A20 Swing-Out Quarter Windows	AJ1	N.A.	144.00	144.00
Harness, Wiring: Trailer, Heavy-Duty. 7-Lead. Included with Z82 Trailing Package	UY7	N.A.	46.00	46.00
Headlamps: Halogen Not available when V22 Deluxe Front Appearance Package is specified	TT4	N.A.	24.00	24.00
Headliners: Regular Cab only. Not available when Z62 or YE9 is specified.				
<i>Vinyl</i>	BB5	N.C.	27.00	27.00
<i>Custom Package.</i> Includes headliner and color-keyed floor covering	VBA	N.A.	75.00	75.00
Heaters: Included when V10 Cold-Climate Package is specified.				
<i>Engine Block. 600 Watts, 120 Volts.</i> Not available when B3J Diesel Equipment is specified.	K05	N.A.	33.00	33.00
<i>Heavy Duty, Front.</i> Not available when C60 Air Conditioning is specified	C42	N.A.	45.00	45.00
Lamps:				
<i>Cargo.</i>	UF2	N.A.	36.00	36.00
<i>Dome and Reading.</i> Not available with VBA Headliner Package or BB5 Headliner. Included with TR9 Auxiliary Lighting. Includes bright lamp bezels	C95	N.A.	33.00	33.00
<i>Roof Marker.</i> Five. C-K2,3 Series only. Without R05 Dual Rear Wheels, available only when NA5 Standard or NA6 High Altitude Emission Equipment is specified. Included when R05 Dual Rear Wheels are specified	U01	N.A.	52.00	52.00

(a) D & H Charges on vehicle and optional equipment include reimbursement to ordering Division for any tax that it has paid, incurred or agreed to pay thereon.
 ◇ State and local taxes not included.

C-K PICKUP

OPTIONS WHEN INSTALLED BY GENERAL MOTORS

Prices shown are effective with initial shipments of 1988 model motor vehicles

Description	Option Number	Factory D&H(a)	List Price	Mfr's Suggested Retail Price◇
OTHER OPTIONS				
Lighter, Cigarette: Included when YE9 is specified	U37	N.A.	25.00	25.00
Lighting, Auxiliary. Includes C95 Dome and Reading Lamp	TR9	N.A.	102.00	102.00
Mirrors, Exterior: LH and RH. <i>Below-Eye-Line Type.</i> 9" x 6.5".				
Painted, Black	D44	N.A.	52.00	52.00
Stainless Steel	D45	N.A.	87.00	87.00
Camper Type. Stainless steel. 7.5" x 10.5". Adjustable arm feature to provide field of vision for vehicles to 96" wide. Shipped loose for dealer installation. Included with Z81 Camper Special	DF2	N.A.	100.00	100.00
Moldings:				
Body Side Black. Not available when YE9, R05 Dual Rear Wheels or B85 Bright Body Side Moldings are specified. Included with Z62	B84	N.A.	59.00	59.00
Body Side Bright. Not available when B84 Black Body Side Moldings, V43 Bumper or R05 Dual Rear Wheels are specified. Available only when B96 Bright Wheel Opening Moldings and Z62 are specified. Included with YE9	B85	N.A.	17.00	17.00
Wheel Opening, Black. Available only when B84 Body Side Black Moldings are specified. Not available when YE9 or R05 Dual Rear Wheels are specified. Also not available on K3 Series. Included with Z62	B74	N.A.	31.00	31.00
Wheel Opening, Bright. Available only when B85 Body Side Bright Moldings and Z62 are specified. Not available when R05 Dual Rear Wheels or V43 Deluxe Bumpers are specified. Also not available on K3 Series. Included with YE9	B96	N.A.	31.00	31.00
Off-Road Chassis Package: <i>K1 Series only.</i> Available only when GL or GM LT265 Tires are specified. Includes F59 Stabilizer and NZZ Skid Plate	Z71	N.A.	310.00	310.00
Operating Convenience Package: Includes power door locks and power windows	ZQ2	N.A.	344.00	344.00
Preliminary Price Information	B3W	N.A.	N.A.	N.A.
Radio Equipment:				
AM Radio	U63	N.A.	122.00	122.00
Electronically Tuned AM/FM Stereo Radio with Seek and Scan	UK4	N.A.	268.00	268.00
Electronically Tuned AM/FM Stereo Radio with Seek and Scan and Digital Clock. Includes premium dual rear speakers	UM7	N.A.	333.00	333.00
Electronically Tuned AM/FM Stereo Radio with Seek and Scan and Stereo Cassette Tape.	UK5	N.A.	390.00	390.00
Electronically Tuned AM/FM Stereo Radio with Seek and Scan, Stereo Cassette Tape and Digital Clock. Includes premium dual rear speakers	UM6	N.A.	454.00	454.00
Electronically Tuned AM Stereo/FM Stereo Radio with Seek and Scan, Stereo Cassette Tape, Graphic Equalizer and Digital Clock. Includes premium dual rear speakers	UX1	N.A.	604.00	604.00
Fixed Mast Antenna. Included with radio	U73	N.A.	41.00	41.00
Seat, Folding Rear. <i>Extended Cab only.</i> Available only when bucket or split bench seats are specified	AM7	N.A.	385.00	385.00
Shock Absorbers: <i>Heavy-Duty. Front and Rear.</i> C-K1 Series only. Not available when Z71 Off Road Package is specified. Included when Z82 Trailering Special is specified	F51	N.A.	36.00	36.00
Skid Plate: <i>Off road.</i> K1-2-3 Series only. Included with Z71 Off-Road Chassis Package. Includes differential, transfer Case and engine shields	NZZ	N.A.	95.00	95.00
Speed Control, Electronic:	K34	N.A.	205.00	205.00
Stabilizer Bar: <i>Front.</i> 1" diameter. Included with Z71 Off-Road Chassis Package or Z81 Camper Special	F59	N.A.	40.00	40.00
Steering Wheels:				
<i>Comfortilt.</i>	N33	N.A.	121.00	121.00
Custom. Included with YE9	N31	N.A.	28.00	28.00
Sport. Available only when YE9 is specified	NK3	N.A.	7.00	7.00

(a) D & H Charges on vehicle and optional equipment include reimbursement to ordering Division for any tax that it has paid, incurred or agreed to pay thereon.

◇ State and local taxes not included.

C-K PICKUP

OPTIONS WHEN INSTALLED BY GENERAL MOTORS

Prices shown are effective with initial shipments of 1988 model motor vehicles

Description	Option Number	Factory D&H(a)	List Price	Mfr's Suggested Retail Price◇
OTHER OPTIONS				
Striping: Available only when ZY1 Solid or ZY2 Two-Tone Paint is specified	D85	N.A.	69.00	69.00
Tank, Fuel: L.H. Frame Mounted. Provides approximately 34-gallon total capacity. Included with Z81 Camper Special Not available on C-K10703	NJ8	N.A.	56.00	56.00
Towing Device: Two front towing hooks.	V76	N.A.	38.00	38.00
Trailer Hitch: Weight Distributing Platform Type. Available only when V43 or VB3 Bumper is specified. Included with Z82 H.D. Trailering	VR4	N.A.	164.00	164.00
Trailering Special: Heavy Duty. Not available on C-K10703. Available only when V43 or VB4 Bumper and MX0 or MX1 Automatic Transmission is specified. Includes VR4 Trailer Hitch, UY7 Wiring Harness, V02 Radiator and Transmission Oil Cooler.				
Without B3J Diesel Equipment.				
C-K1 Series only. Also includes F51 Shock Absorbers and KC4 Engine Oil Cooler	Z82	N.A.	435.00	435.00
C-K2-3 Series only. Also includes KC4 Engine Oil Cooler With B3J Diesel Equipment.	Z82	N.A.	399.00	399.00
C-K2-3 Series only	Z82	N.A.	273.00	273.00
Wheel Trim: Bright Metal.				
Wheel Covers. Not available when R05 Dual Rear Wheels are specified	P01	N.A.	42.00	42.00
Trim Rings. C3 Series only. Available only when R05 Dual Rear Wheels are specified	P06	N.A.	60.00	60.00
Wheels:				
Rally. Includes special hub caps and trim rings.	N67	N.A.	75.00	75.00
Styled. Includes special hub caps. Four wheels only. C-K1 Series only. C1 Series not available when P205/75R15 tires are specified	PA6	N.A.	185.00	185.00
Aluminum, Cast. Four Wheels only. C1 Series only. Not available when P205/75R15 tires are specified. Includes 15" x 7" wheels and special hub caps.	N90	N.A.	295.00	295.00
Aluminum, Forged. Four Wheels only. K10703-K10903 only Includes 16" x 7" wheels and special hub caps	PF4	N.A.	295.00	295.00
Wheels, Dual Rear: C-3 only. Includes plastic rear fender extensions with side marker lamps located on front and rear sides and dual rear chassis provisions. Not available when G80 Axle is specified. Includes UO1 Roof Marker Lamps				
Without MX1 Automatic Transmission	R05	N.A.	1038.00	1038.00
With MX1 Automatic Transmission. Includes V02 H.D. Radiator and Transmission Oil Cooler	R05	N.A.	1101.00	1101.00
Wheels, Single Rear: Not available when R05 Dual Rear Wheels are specified	R04	NO ADDITIONAL CHARGE		
Windows:				
Sliding Rear. Not available when AJ1 Deep Tinted Glass is specified	A28	N.A.	113.00	113.00
Swing: Out Rear Quarter. Extended Cab only. Included with AJ1 or AA3 Deep Tinted Glass	A20	N.A.	43.00	43.00
Windshield Wiper System: Intermittent	CD4	N.A.	59.00	59.00

- (a) D & H Charges on vehicle and optional equipment include reimbursement to ordering Division for any tax that it has paid, incurred or agreed to pay thereon.
 ◇ State and local taxes not included.

C/K PICKUP

CAB & BODY FEATURES
CAB CONSTRUCTION
CAB DIMENSIONS
COLOR & TRIM CHARTS
TWO-TONES

C/K PICKUP

CHEYENNE/SIERRA SL FEATURES—STANDARD MODEL

The Cheyenne/Sierra SL standard models include the following items as standard equipment

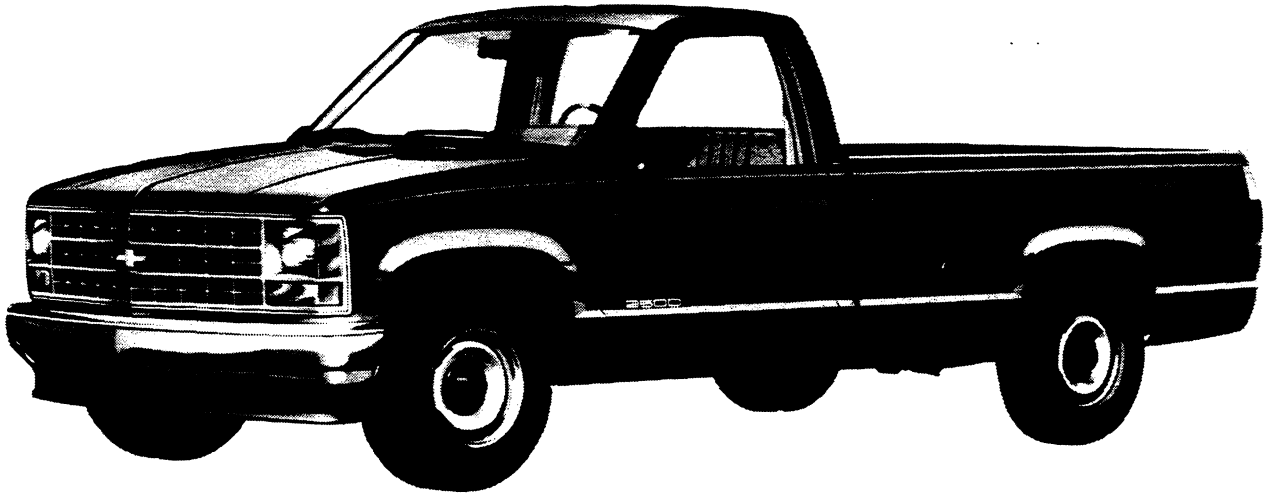

EXTERIOR

- **Bumper:** Front; chromed
- **Color:** See Interior and Exterior Color Selection Chart
- **Grille:** Molded plastic; painted light argent with dark argent air intake areas; Chevrolet emblem/GMC letters at center of grille
- **Horn:** Single, electric, low-note
- **Hub Caps:** Bright metal with black trim (single rear wheel models only)
- **Keys:** Two-key system; with separate keys for ignition switch and door locks
- **Lettering, "Chevrolet/GMC" Tailgate:** Decal with outlined block letters
- **Lights:**
 - Backup lamps: Two rear (integral with tail lamps)
 - Combination parking/direction/hazard: Two front
 - Combination tail/stop/direction/hazard: Two rear
 - Headlamps: Two, rectangular
 - License plate lamp: Single rear
 - Side marker lamps with reflectors: Two front; two rear (integral with tail lamps)
- **Mirrors:** RH and LH fixed arm with adjustable heads; black finish
- **Moldings:** Wheel opening flare moldings (K3500 models only); black with solid color paint, painted lower body color with two-tones
- **Nameplates:** Bright "Cheyenne/Sierra SL" nameplates on upper rear side quarter panel. Series designation nameplates on doors; for 4 wheel drive models, 4x4 decals coordinated with exterior body color at rear of pickup box side panels (located on extension fenders on models with dual rear wheels)
- **Pickup Box:** All-steel double sidewall and tailgate construction; painted body color
- **Spare Tire Carrier:** Winch type mounted under frame at rear
- **Tools:** Mechanical jack and wheel wrench
- **Wheels:** Painted silver with black hub ornament
- **Windshield Wipers and Washers:** Electric, 2-speed wipers with black finish on exposed metal portions; demand-type washer system with fluidic nozzles

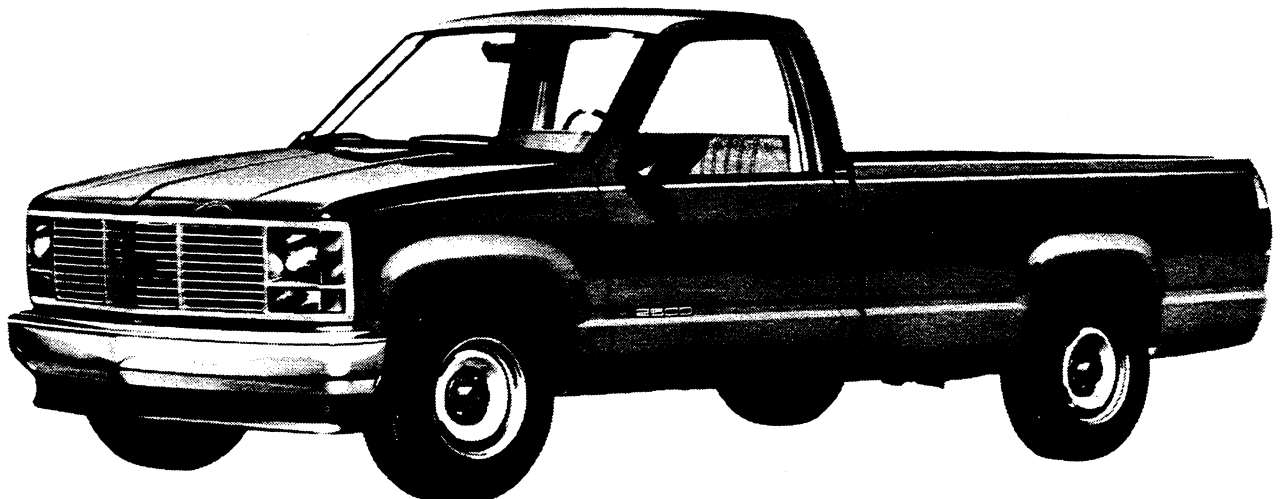

PRELIMINARY INFORMATION—SUBJECT TO CHANGE

C/K PICKUP

CHEYENNE/SIERRA SL FEATURES—STANDARD MODEL

The Cheyenne/Sierra SL standard models include the following items as standard equipment

INTERIOR

- **Armrests:** RH and LH; integral with door trim panels
- **Ashtray:** In middle of instrument panel
- **Coat Hooks:** RH (all models) and LH (Extended Cab models)
- **Colors:**
 - Painted areas: Same as exterior primary color choice
 - Interior trim: Coordinated with seat trim color choice
- **Door Sill Plates:** Door-opening protection and floor mat retention; full-length; dark gray plastic
- **Door Trim Panels:** Color-keyed, grained molded plastic with integral armrests
- **Dome Lamp:** LH door-operated switch
- **Floor Covering:** Embossed black rubber mats with insulator
- **Glass:** Tinted, all windows (Extended Cabs only)
- **Headliner:** Full length color-keyed cloth with insulation backing; includes matching retainer moldings (Extended Cabs only).
- **Heater and Defogger:** Deluxe-air, with side window defogger
- **Hood Lock Release:** Handle located on LH side under instrument panel
- **Instrument Cluster Bezel:** Black crackle finish with bright trim
- **Instruments:**
 - Gages: Speedometer, odometer and fuel
 - Switches: Main, for control of exterior lights, instrument cluster lights, and cab interior lights; multi-function switch on steering column for direction signals by moving lever up or down (includes lane change position), headlamp beams by pulling lever toward driver, windshield wiper by turning band marked "WIPER" toward or away from driver, and windshield washer by pushing in the lever knob; ignition with key-in warning buzzer; hazard warning; heater fan
 - Warning lights: Generator, oil pressure, engine temperature, seat belt, service-parking brake, direction/hazard signal, and high beam
- **Instrument Panel Pad:** Color-keyed, energy-absorbing foam type with grained vinyl skin
- **Insulation and Sound Deadening Material:** Dash (firewall), under front floor mat, under rear floor mat on Extended Cabs, on Extended Cab rear quarter and cab back panels
- **Lights:** Instrument cluster and cab interior lights
- **Mirror, Rearview:** 10" prismatic with soft vinyl rim
- **Seats:** Regular Cabs—Full width, full depth foam bench-type with embossed, grained, all-vinyl trim and folding backrest. Also available at extra cost: Base cloth bench seat with folding backrest.
Extended Cabs—Full width, full depth foam bench-type with embossed, grained, all-vinyl trim and folding backrest. Also available at extra cost: 1) vinyl split front bench seats with folding backrests and RH easy-entry feature (requires folding rear bench seat); 2) vinyl folding rear bench seat (requires split front bench seat). See Interior and Exterior Color Selection Chart for color and trim availability.
- **Seat Belts:** Front (all models): non-detachable combination lap and shoulder belts for outboard positions with emergency-locking retractors and switch in driver's lap belt retractor for buzzer warning system (RH belt is equipped with child seat restraint feature); lap belt with manual adjustment for center position. Rear (Extended Cabs only): lap belts with emergency-locking retractors for all positions. All seat belts are color-keyed with pushbutton type buckles
- **Steering Wheel and Column:** Black, soft plastic wheel with 4 spokes; black energy-absorbing steering column with anti-theft locking feature
- **Storage Box:** In RH side of instrument panel; door has bright turn-type latch release and beverage holder on inside of door
- **Sunshades:** RH and LH padded; color-keyed
- **Trim Panels:** Cab rear side panels and cab rear upper and lower panels (Extended Cabs only)

PRELIMINARY INFORMATION—SUBJECT TO CHANGE

C/K PICKUP

SCOTTSDALE/SIERRA SLX MODEL OPTION—RPO Z62 (FOR ALL MODELS)

This option includes all Cheyenne/Sierra SL standard model items plus the additions or substitutions listed below



GMC model shown (Chevrolet model available)

EXTERIOR

- **Bright Appearance Items:**
"Scottsdale/Sierra SLX" nameplates on upper rear side quarter panel
- **Bumper Rub Strips:** Black
- **Moldings:** Black plastic body side moldings. Black wheel opening flare moldings (except K3500 models) (Fleetside/Wide-side models with single rear wheels only)

INTERIOR

- **Coat Hooks:** Additional coat hook on LH side
- **Door Sill Plates:** Color-keyed
- **Door Trim Panels:** Color-keyed grained molded plastic, with soft vinyl trim, map pocket, integral armrests and Scottsdale/Sierra SLX emblems
- **Floor Covering:** Color-keyed rubber mats
- **Headliner:** Full-length color-keyed cloth with insulation backing; includes matching retainer moldings (Regular cabs only)
- **Pillar Trim Panels:** Color-keyed molded plastic on door pillars and roof side
- **Seats:**
Regular Cabs—Standard cloth bench seat. Also available at extra cost: 1) Custom vinyl bench seat and 2) Custom vinyl bucket seats
Extended Cabs—Custom vinyl bench seat. Also available at extra cost: 1) Custom vinyl split front bench seat with RH easy-entry feature; 2) Custom vinyl front bucket seats with RH easy-entry feature; 3) Custom vinyl rear folding bench seat
See Interior and Exterior Color Selection Chart for color and trim availability.
- **Storage Tray:** Full width on floor behind seat
- **Trim Panels:** (Regular Cab only) Cab rear side panels and cab rear upper and lower panels

PRELIMINARY INFORMATION—SUBJECT TO CHANGE

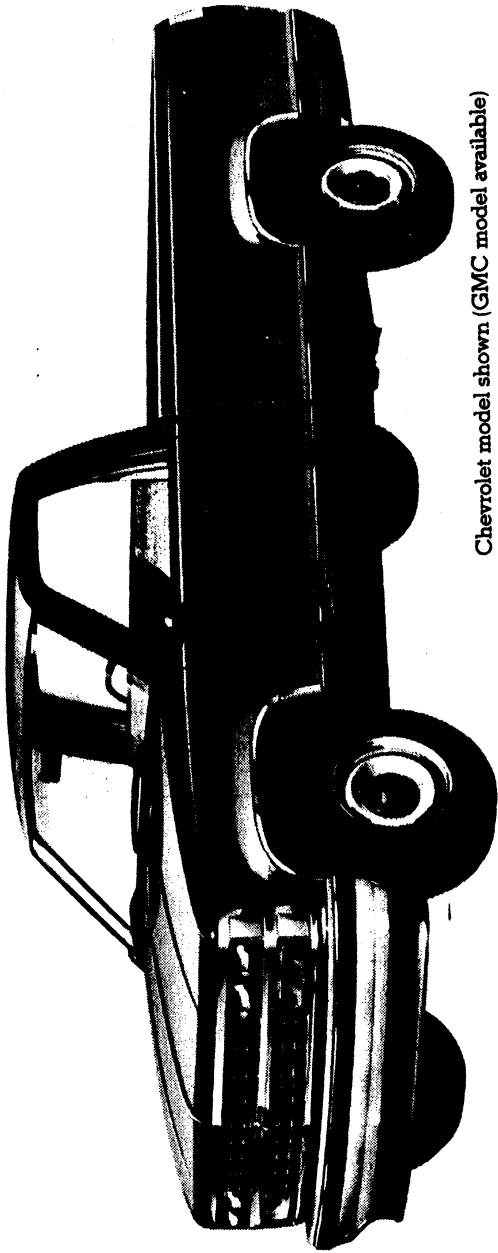

Chevrolet model shown (GMC model available)

EXTERIOR

- **Bright Appearance Items:**
 - Silverado/Sierra SLE nameplates on upper rear side quarter panels
 - Chrome-trimmed grille
 - "Chevrolet/GMC" letters nameplate on tailgate applique panel (Fleetside/Wideside only)
 - Bright applique panel fitted over central area of tailgate (Fleet-side/Wideside only)
 - Wheel-opening lip moldings (except K3 models) (Fleetside/Wideside models with single rear wheels only)
- **Bumper Rub Strips:** Black with bright trim
- **Cab-to-Fender Insulators:** Gasoline models only
- **Hood Insulator**
- **Horns:** Additional, electric, high note
- **Moldings:** Black body side with bright trim
- **Special Headlamps:** Halogen, rectangular, dual RH and LH

INTERIOR

- **Cab-to-Fender Insulators**
 - **Cigarette Lighter:** In ashtray
 - **Cowl Panel Trim:** Color-keyed carpet on cowl side panels with insulator
 - **Door Trim Panels:** Two-tone soft vinyl over plastic with integral armrests, map pocket, door closing assist straps, and Silverado/SLE emblems
 - **Floor Covering:** Color-keyed carpeting and sill plates
 - **Hood Insulator**
 - **Insulation:** On cab back panel
 - **Seats:**
 - Regular Cabs—Choice of Custom Vinyl or Custom Cloth bench seat. Also available at extra cost: Custom vinyl or custom cloth front bucket seats
- Extended Cabs—Choice of Custom Vinyl or Custom Cloth front bench seat with RH easy-entry feature. Also available at extra cost: 1) Custom vinyl or custom cloth front bucket seats with RH easy-entry feature; and 2) Matching Custom Vinyl or Custom Cloth rear folding bench seat. See Interior and Exterior Color Selection Chart for color trim availability
- **Steering Wheel:** Custom 4-spoke
 - **Sunshades:** RH & LH cloth covered with storage strap on LH
 - **Trim Panels:** Color-keyed carpet on cab back panel
 - **Visor Mirror:** On RH sun visor

C/K REGULAR CAB PICKUP

INTERIOR AND EXTERIOR COLOR AVAILABILITY CHART

WITH ZY1 AND ZY2 PAINT

PLEASE NOTE: Below are the interior trim color and exterior paint combinations recommended by Chevrolet/GMC. They are the only available interior and exterior combinations allowed.

TRIM LEVEL Seat Type		Decor	INTERIOR COLORS					D85 STRIPING CHART RECOMMENDED COMBINATIONS STRIPE COLORS					
			Beige	Blue	Garnet	Gray	Saddle						
CHEYENNE/SIERRA SL Vinyl Bench Seat Cloth Bench Seat		STD	VUU1	VDD1	VRR1	VQQ1	VSS1						
			CUU1	CDD1	CRR1	CQQ1	CSS1						
SCOTTSDALE/SIERRA SLE Cloth Bench Seat Custom Vinyl Bench Seat Custom Vinyl Bucket Seat		Z62	CUU1	CDD1	CRR1	CQQ1	CSS1						
			XUU1	XDD1	XRR1	XQQ1	XSS1						
				XDD2	XRR2		XSS2						
SILVERADO/SIERRA SLX Custom Cloth Bench Seat Custom Vinyl Bench Seat Custom Cloth Bucket Seat Custom Vinyl Bucket Seat		YE9	LUU1	LDD1	LRR1	LQQ1	LSS1						
			XUU1	XDD1	XRR1	XQQ1	XSS1						
				LDD2	LRR2	LQQ2	LSS2						
				XDD2	XRR2		XSS2						
EXTERIOR COLORS w/ZY1 & ZY2 PAINT	Color Code 1	Color Code 2	INTERIOR & EXTERIOR COMBINATIONS SHOWN ARE THE ONLY COMBINATIONS AVAILABLE				DK BLUE	DK BROWN	COPPER BEIGE	GOLD	SILVER	VERMILLION	
BLACK, SABLE (METALLIC)	18	18		X		X				X			
BLACK, SABLE (METALLIC)	18	18							X				
BLACK, SABLE (METALLIC)	18	18			X						X		
BLACK, SABLE (METALLIC)	18	18	X										
Gold, Adobe (Metallic)	18	52						X	X				
Quicksilver, (Metallic)	18	96				X				X			
Red, Flame*	18	70			X						X		
BLUE, ICED (METALLIC)	22	22		X		X				X			
Blue, Pacific (Metallic)	22	30		X		X				X			
Quicksilver, (Metallic)	22	96		X		X				X			
White, Summit	22	50		X		X				X			
BLUE, PACIFIC (METALLIC)	30	30		X		X					X		
BLUE, PACIFIC (METALLIC)	30	30							X				
Blue, Iced (Metallic)*	30	22		X		X				X			
Quicksilver, (Metallic)	30	96		X		X				X			
White, Summit*	30	50		X						X			
White, Summit*	30	50							X				
BRANDYWINE (METALLIC)	95	95							X				
BRANDYWINE (METALLIC)	95	95			X						X		
Black, Sable (Metallic)	95	18			X						X		
Quicksilver, (Metallic)	95	96			X					X			
White, Summit*	95	50			X						X		
BROWN, SPICE (METALLIC)	32	32	X						X				
Gold, Adobe (Metallic)	32	52	X						X				
Sandstone, (Metallic)	32	58	X					X	X				
GOLD, ADOBE (METALLIC)	52	52	X					X	X				
Black, Sable (Metallic)	52	18						X	X				
Brown, Spice (Metallic)	52	32	X						X				
QUICKSILVER, (METALLIC)	96	96		X	X	X					X		
Black, Sable (Metallic)	96	18				X					X		
Blue, Pacific (Metallic)	96	30		X			X						
Blue, Iced (Metallic)*	96	22		X			X						
Brandywine, (Metallic)	96	95			X						X		
Red, Flame*	96	70			X						X		
RED, FLAME	70	70			X	X					X		
Black, Sable (Metallic)	70	18			X						X		
Black, Sable (Metallic)	70	18				X			X				
Quicksilver, (Metallic)	70	96				X			X				
Quicksilver, (Metallic)	70	96			X						X		
White, Summit*	70	50			X						X		
White, Summit*	70	50				X			X				
SANDSTONE (METALLIC)	58	58					X	X					
SANDSTONE (METALLIC)	58	58	X					X	X				
Black, Sable (Metallic)	58	18	X					X	X				
Brown, Spice (Metallic)	58	32	X				X	X	X				
WHITE, SUMMIT	50	50		X		X	X						
WHITE, SUMMIT	50	50	X				X		X				
WHITE, SUMMIT	50	50			X						X		
Blue, Pacific (Metallic)	50	30		X			X						
Blue, Iced (Metallic)*	50	22		X			X						
Brandywine, (Metallic)	50	95			X						X		
Brown, Spice (Metallic)	50	32				X			X				
Quicksilver, (Metallic)	50	96			X						X		
Red, Flame*	50	70			X						X		

*N/A K3500 models

C/K EXTENDED CAB PICKUP

INTERIOR AND EXTERIOR COLOR AVAILABILITY CHART

WITH ZY1 AND ZY2 PAINT

PLEASE NOTE: Below are the interior trim color and exterior paint combinations recommended by Chevrolet/GMC. They are the only available interior and exterior combinations allowed.

TRIM LEVEL		INTERIOR COLORS									
Seat Type		Decor	Blue	Garnet	Saddle						
CHEYENNE/SIERRA SL Vinyl Bench Seat		STD	VDD1	VRR1	VSS1						
#Vinyl Split Bench Seat			VDD3	VRR3	VSS3						
SCOTTSDALE/SIERRA SLE Custom Vinyl Bench Seat		Z62	XDD1	XRR1	XSS1						
#Custom Vinyl Split Bench Seat			XDD3	XRR3	XSS3						
#Custom Vinyl Bucket Seat			XDD2	XRR2	XSS2						
SILVERADO/SIERRA SLX #Custom Cloth Split Bench Seat		YE9	LDD3	LRR3	LSS3						
#Custom Vinyl Split Bench Seat			XDD3	XRR3	XSS3						
#Custom Cloth Bucket Seat			LDD2	LRR2	LSS2						
#Custom Vinyl Bucket Seat			XDD2	XRR2	XSS2						
EXTERIOR COLORS w/ZY1 & ZY2 PAINT		Color Code 1	Color Code 2	INTERIOR & EXTERIOR COMBINATIONS SHOWN ARE THE ONLY COMBINATIONS AVAILABLE			D85 STRIPING CHART RECOMMENDED COMBINATIONS STRIPE COLORS				
				DK BLUE	DK BROWN	COPPER BEIGE	GOLD	SILVER	VERMILLION		
BLACK, SABLE (METALLIC)	18	18	X					X			
BLACK, SABLE (METALLIC)	18	18		X			X				
BLACK, SABLE (METALLIC)	18	18		X						X	
Gold, Adobe (Metallic)	18	52					X				
Red, Flame★	18	70		X						X	
BLUE, ICED (METALLIC)	22	22	X					X			
Blue, Pacific (Metallic)	22	30	X					X			
Quicksilver, (Metallic)	22	96	X					X			
White, Summit★	22	50	X					X			
BLUE, PACIFIC (METALLIC)	30	30	X							X	
BLUE, PACIFIC (METALLIC)	30	30		X			X				
Blue, Iced (Metallic)★	30	22	X					X			
Quicksilver, (Metallic)	30	96	X					X			
White, Summit★	30	50	X					X			
White, Summit★	30	50		X			X				
BRANDYWINE (METALLIC)	95	95					X				
BRANDYWINE (METALLIC)	95	95		X						X	
Black, Sable (Metallic)	95	18		X						X	
Quicksilver, (Metallic)	95	96		X				X			
White, Summit★	95	50		X				X		X	
BROWN, SPICE (METALLIC)	32	32					X				
Gold, Adobe (Metallic)	32	52					X				
GOLD, ADOBE (METALLIC)	52	52					X				
Black, Sable (Metallic)	52	18					X				
QUICKSILVER, (METALLIC)	96	96	X	X						X	
Blue, Pacific (Metallic)	96	30	X		X						
Blue, Iced (Metallic)★	96	22	X		X						
Brandywine, (Metallic)	96	95		X						X	
Red, Flame★	96	70		X						X	
RED, FLAME	70	70		X						X	
Black, Sable (Metallic)	70	18		X						X	
Black, Sable (Metallic)	70	18					X				
Quicksilver, (Metallic)	70	96					X				
Quicksilver, (Metallic)	70	96		X						X	
White, Summit★	70	50		X						X	
White, Summit★	70	50					X				
SANDSTONE (METALLIC)	58	58					X				
Brown, Spice (Metallic)	58	32					X				
WHITE, SUMMIT	50	50	X								
WHITE, SUMMIT	50	50		X				X			
WHITE, SUMMIT	50	50		X						X	
Blue, Pacific (Metallic)	50	30	X		X						
Blue, Iced (Metallic)★	50	22	X		X						
Brandywine, (Metallic)	50	95		X						X	
Brown, Spice (Metallic)	50	32					X				
Quicksilver, (Metallic)	50	96		X						X	
Red, Flame★	50	70		X						X	

★ N/A K3500 models

#Requires AM7 Folding Rear Seat

PRELIMINARY INFORMATION—SUBJECT TO CHANGE

C/K REGULAR CAB PICKUP

INTERIOR AND EXTERIOR COLOR AVAILABILITY CHART

C/K1500-2500 AND C3500 MODELS ONLY

WITH ZY3 AND ZY4 PAINT

PLEASE NOTE: Below are the interior trim color and exterior paint combinations recommended by Chevrolet/GMC. They are the only available interior and exterior combinations allowed.

TRIM LEVEL Seat Type	Decor	INTERIOR COLORS						
		Beige	Blue	Garnet	Gray	Saddle		
CHEYENNE/SIERRA SL Vinyl Bench Seat	STD	VUU1	VDD1	VRR1	VQQ1	VSS1		
		CUU1	CDD1	CRR1	CQQ1	CSS1		
SCOTSDALE/SIERRA SLX Cloth Bench Seat	Z62	CUU1	CDD1	CRR1	CQQ1	CSS1		
		XUU1	XDD1	XRR1	XQQ1	XSS1		
		XUU1	XDD2	XRR2	XQQ1	XSS2		
SILVERADO/SIERRA SLE Custom Cloth Bench Seat	YE9	LUU1	LDD1	LRR1	LQQ1	LSS1		
		XUU1	XDD1	XRR1	XQQ1	XSS1		
		XUU1	XDD2	XRR2	LQQ2	LSS2		
		XUU1	XDD2	XRR2	LQQ2	XSS2		
EXTERIOR COLORS w/ZY3, & ZY4 PAINT	Color Code 1	Color Code 2	INTERIOR & EXTERIOR COMBINATIONS SHOWN ARE THE ONLY COMBINATIONS AVAILABLE					STRIPE COLOR
BLACK, SABLE (Metallic)/ Gold, Adobe (Metallic)	18	52					X	Gold/Black
BLACK, SABLE (Metallic)/ Red, Flame	18	70			X			Vermillion/Dark Red
BLACK, SABLE (Metallic)/Quicksilver	18	96				X		Vermillion/Silver
BLUE, ICED (Metallic)/ Blue, Pacific (Metallic)	22	30		X			X	Light Blue/Dark Blue
BLUE, ICED (Metallic)/ Quicksilver (Metallic)	22	96		X			X	Light Blue/Dark Blue
BLUE, ICED (Metallic)/ White, Summit	22	50		X			X	Light Blue/Dark Blue
BLUE, PACIFIC (Metallic)/ Blue, Iced (Metallic)	30	22		X			X	Light Blue/Dark Blue
BLUE, PACIFIC (Metallic)/ Quicksilver, (Metallic)	30	96		X			X	Vermillion/Silver
BLUE, PACIFIC (Metallic)/ White, Summit	30	50		X				Light Blue/Dark Blue
BLUE, PACIFIC (Metallic)/ White, Summit	30	50					X	Gold/Black
BRANDYWINE/Black, Sable (Metallic)	95	18			X			Vermillion/Dark Red
BRANDYWINE/Quicksilver (Metallic)	95	96	X		X			Vermillion/Silver
BRANDYWINE/White, Summit	95	50			X			Vermillion/Dark Red
BROWN, SPICE (Metallic)/ Gold, Adobe (Metallic)	32	52	X				X	Doeskin/Carmine
BROWN, SPICE (Metallic)/ Sandstone (Metallic)	32	58	X					Doeskin/Carmine
GOLD, ADOBE (Metallic)/ Black, Sable (Metallic)	52	18					X	Doeskin/Carmine
GOLD, ADOBE (Metallic)/ Brown, Spice (Metallic)	52	32	X				X	Doeskin/Carmine
QUICKSILVER (Metallic)/ Black, Sable (Metallic)	96	18				X		Vermillion/Silver
QUICKSILVER (Metallic)/ Blue, Pacific (Metallic)	96	30		X				Light Blue/Dark Blue
QUICKSILVER (Metallic)/ Blue, Iced (Metallic)	96	22		X				Light Blue/Dark Blue
QUICKSILVER (Metallic)/ Brandywine (Metallic)	96	95			X			Vermillion/Silver
QUICKSILVER (Metallic)/ Red, Flame	96	70			X			Vermillion/Silver
RED, FLAME/Black, Sable	70	18					X	Gold/Black
RED, FLAME/Black, Sable	70	18			X			Vermillion/Dark Red
RED, FLAME/Quicksilver (Metallic)	70	96			X			Vermillion/Dark Red
RED, FLAME/Quicksilver (Metallic)	70	96			X		X	Vermillion/Silver
RED, FLAME/White, Summit	70	50			X			Vermillion/Dark Red
RED, FLAME/White, Summit	70	50			X		X	Gold/Black
SANDSTONE (Metallic)/ Black, Sable (Metallic)	58	18	X					Doeskin/Carmine
SANDSTONE (Metallic)/ Brown, Spice (Metallic)	58	32	X				X	Doeskin/Carmine
WHITE, SUMMIT/Blue Pacific (Metallic)	50	30		X				Light Blue/Dark Blue
WHITE, SUMMIT/Blue, Iced (Metallic)	50	22		X				Light Blue/Dark Blue
WHITE, SUMMIT/Brown, Spice (Metallic)	50	32					X	Doeskin/Carmine
WHITE, SUMMIT/Brandywine (Metallic)	50	95			X			Vermillion/Dark Red
WHITE, SUMMIT/Red, Flame	50	70			X			Vermillion/Silver
WHITE, SUMMIT/Quicksilver (Metallic)	50	96			X			Vermillion/Silver

PRELIMINARY INFORMATION—SUBJECT TO CHANGE

C/K EXTENDED CAB PICKUP

INTERIOR AND EXTERIOR COLOR AVAILABILITY CHART

C/K1500-2500 AND C3500 MODELS ONLY

WITH ZY3 AND ZY4 PAINT

PLEASE NOTE: Below are the interior trim color and exterior paint combinations recommended by Chevrolet/GMC. They are the only available interior and exterior combinations allowed.

TRIM LEVEL		Decor	INTERIOR COLORS			
Seat Type			Blue	Garnet	Saddle	
CHEYENNE/SIERRA SL Vinyl Bench Seat		STD	VDD1	VRR1	VSS1	
#Vinyl Split Bench Seat			VDD3	VRR3	VSS3	
SCOTSDALE/SIERRA SLX Custom Vinyl Bench Seat		Z62	XDD1	XRR1	XSS1	
#Custom Vinyl Split Bench Seat			XDD3	XRR3	XSS3	
#Custom Vinyl Bucket Seat			XDD2	XRR2	XSS2	
SILVERADO/SIERRA SLE #Custom Cloth Split Bench Seat		YE9	LDD3	LRR3	LSS3	
#Custom Vinyl Split Bench Seat			XDD3	XRR3	XSS3	
#Custom Cloth Bucket Seat			LDD2	LRR2	LSS2	
#Custom Vinyl Bucket Seat			XDD2	XRR2	XSS2	
EXTERIOR COLORS w/ZY3, & ZY4 PAINT	Color Code 1	Color Code 2	INTERIOR & EXTERIOR COMBINATIONS SHOWN ARE THE ONLY COMBINATIONS AVAILABLE			STRIPE COLOR
BLACK, SABLE (Metallic)/ Gold, Adobe (Metallic)	18	52			X	Gold/Black
BLACK, SABLE (Metallic)/ Red, Flame	18	70		X		Vermillion/Dark Red
BLUE, ICED (Metallic)/ Blue, Pacific (Metallic)	22	30	X		X	Light Blue/Dark Blue
BLUE, ICED (Metallic)/ Quicksilver (Metallic)	22	96	X			Light Blue/Dark Blue
BLUE, ICED (Metallic)/ White, Summit	22	50	X			Light Blue/Dark Blue
BLUE, PACIFIC (Metallic)/ Blue, Iced (Metallic)	30	22	X			Light Blue/Dark Blue
BLUE, PACIFIC (Metallic)/ Quicksilver (Metallic)	30	96	X			Vermillion/Silver
BLUE, PACIFIC (Metallic)/ White, Summit	30	50	X			Light Blue/Dark Blue
BLUE, PACIFIC (Metallic)/ White, Summit	30	50			X	Gold/Black
BRANDYWINE/Black, Sable (Metallic)	95	18		X		Vermillion/Dark Red
BRANDYWINE/Quicksilver (Metallic)	95	96		X		Vermillion/Silver
BRANDYWINE/White, Summit	95	50		X		Vermillion/Dark Red
BROWN, SPICE (Metallic)/ Gold, Adobe (Metallic)	32	52			X	Doeskin/Carmine
GOLD, ADOBE (Metallic)/ Black, Sable (Metallic)	52	18			X	Doeskin/Carmine
GOLD, ADOBE (Metallic)/ Brown, Spice (Metallic)	52	32			X	Doeskin/Carmine
QUICKSILVER (Metallic)/ Blue, Pacific (Metallic)	96	30	X			Light Blue/Dark Blue
QUICKSILVER (Metallic)/ Blue, Iced (Metallic)	96	22	X			Light Blue/Dark Blue
QUICKSILVER (Metallic)/ Brandywine (Metallic)	96	95		X		Vermillion/Silver
QUICKSILVER (Metallic)/ Red, Flame	96	70		X		Vermillion/Silver
RED, FLAME/Black, Sable	70	18			X	Gold/Black
RED, FLAME/Black, Sable	70	18		X		Vermillion/Dark Red
RED, FLAME/Quicksilver (Metallic)	70	96		X		Vermillion/Dark Red
RED, FLAME/Quicksilver (Metallic)	70	96			X	Vermillion/Silver
RED, FLAME/White, Summit	70	50		X		Vermillion/Dark Red
RED, FLAME/White, Summit	70	50			X	Gold/Black
SANDSTONE (Metallic)/ Brown, Spice (Metallic)	58	32			X	Doeskin/Carmine
WHITE, SUMMIT/Blue Pacific (Metallic)	50	30	X			Light Blue/Dark Blue
WHITE, SUMMIT/Blue, Iced (Metallic)	50	22	X			Light Blue/Dark Blue
WHITE, SUMMIT/Brown, Spice (Metallic)	50	32			X	Doeskin/Carmine
WHITE, SUMMIT/Brandywine (Metallic)	50	95		X		Vermillion/Dark Red
WHITE, SUMMIT/Red, Flame	50	70		X		Vermillion/Silver
WHITE, SUMMIT/Quicksilver (Metallic)	50	96		X		Vermillion/Silver

#Requires AM7 Folding Rear Seat

PRELIMINARY INFORMATION—SUBJECT TO CHANGE

C/K REGULAR CAB PICKUP
INTERIOR AND EXTERIOR COLOR AVAILABILITY CHART
K3500 MODEL ONLY
WITH ZY3 AND ZY4 PAINT

PLEASE NOTE: Below are the interior trim color and exterior paint combinations recommended by Chevrolet/GMC. They are the only available interior and exterior combinations allowed.

TRIM LEVEL				INTERIOR COLORS					STRIPE COLOR
Seat Type				Decor	Beige	Blue	Garnet	Gray	
CHEYENNE/SIERRA SL				STD					
Vinyl Bench Seat					VUU1	VDD1	VRR1	VQQ1	VSS1
Cloth Bench Seat					CUU1	CDD1	CRR1	CQQ1	CSS1
SCOTTSDALE/SIERRA SLX				Z62					
Cloth Bench Seat					CUU1	CDD1	CRR1	CQQ1	CSS1
Custom Vinyl Bench Seat					XUU1	XDD1	XRR1	XQQ1	XSS1
Custom Vinyl Bucket Seat						XDD2	XRR2		XSS2
SILVERADO/SIERRA SLE				YE9					
Custom Cloth Bench Seat					LUU1	LDD1	LRR1	LQQ1	LSS1
Custom Vinyl Bench Seat					XUU1	XDD1	XRR1	XQQ1	XSS1
Custom Cloth Bucket Seat						LDD2	LRR2	LQQ2	LSS2
Custom Vinyl Bucket Seat						XDD2	XRR2		XSS2
EXTERIOR COLORS w/ZY3 & ZY4 PAINT	Two-Tone Available	Color Code 1	Color Code 2	INTERIOR & EXTERIOR COMBINATIONS SHOWN ARE THE ONLY COMBINATIONS AVAILABLE					STRIPE COLOR
BLACK, SABLE (Metallic)/ Gold, Adobe (Metallic)	ZY4 only	18	52					X	Gold/Black
BLACK, SABLE (Metallic)/ Quicksilver	All	18	96				X		Vermillion/Silver
BLACK, SABLE (Metallic)/ Red, Flame	ZY4 only	18	70			X			Vermillion/Dark Red
BLUE, ICED (Metallic)/ Blue, Pacific (Metallic)	ZY3 only	22	30		X		X		Light Blue/Dark Blue
BLUE, ICED (Metallic)/ Quicksilver (Metallic)	ZY3 only	22	96		X		X		Light Blue/Dark Blue
BLUE, PACIFIC (Metallic)/ Blue, Iced (Metallic)	ZY4 only	30	22		X		X		Light Blue/Dark Blue
BLUE, PACIFIC (Metallic)/ Quicksilver (Metallic)	All	30	96		X		X		Vermillion/Silver
BLUE, PACIFIC (Metallic)/ White, Summit	ZY4 only	30	50		X				Light Blue/Dark Blue
BLUE, PACIFIC (Metallic)/ White, Summit	ZY4 only	30	50					X	Gold/Black
BRANDYWINE/ Black, Sable (Metallic)	All	95	18			X			Vermillion/Dark Red
BRANDYWINE/ Quicksilver (Metallic)	All	95	96	X		X			Vermillion/Silver
BRANDYWINE/White, Summit	ZY4 only	95	50			X			Vermillion/Dark Red
BROWN, SPICE (Metallic)/ Gold, Adobe (Metallic)	ZY4 only	32	52	X				X	Doeskin/Carmine
BROWN, SPICE (Metallic)/ Sandstone (Metallic)	ZY4 only	32	58	X					Doeskin/Carmine
GOLD, ADOBE (Metallic)/ Black, Sable (Metallic)	ZY3 only	52	18					X	Doeskin/Carmine
GOLD, ADOBE (Metallic)/ Brown, Spice (Metallic)	ZY3 only	52	32	X					Doeskin/Carmine
QUICKSILVER (Metallic)/ Black, Sable (Metallic)	All	96	18				X		Vermillion/Silver
QUICKSILVER (Metallic)/ Blue, Iced (Metallic)	All	96	22		X				Light Blue/Dark Blue
QUICKSILVER (Metallic)/ Blue, Pacific (Metallic)	All	96	30		X				Light Blue/Dark Blue
QUICKSILVER (Metallic)/ Brandywine (Metallic)	All	96	95			X			Vermillion/Silver
QUICKSILVER (Metallic)/ Red, Flame	ZY4 only	96	70			X			Vermillion/Silver
RED, FLAME/Black, Sable	ZY3 only	70	18					X	Gold/Black
RED, FLAME/Black, Sable	ZY3 only	70	18			X			Vermillion/Dark Red
RED, FLAME/ Quicksilver (Metallic)	ZY3 only	70	96			X			Vermillion/Dark Red
RED, FLAME/ Quicksilver (Metallic)	ZY3 only	70	96					X	Vermillion/Silver
SANDSTONE (Metallic)/ Black, Sable (Metallic)	ZY3 only	58	18	X					Doeskin/Carmine
SANDSTONE (Metallic)/ Brown, Spice (Metallic)	ZY3 only	58	32	X				X	Doeskin/Carmine
WHITE, SUMMIT/ Blue, Iced (Metallic)	ZY3 only	50	22		X				Light Blue/Dark Blue
WHITE, SUMMIT/ Blue Pacific (Metallic)	ZY3 only	50	30		X				Light Blue/Dark Blue
WHITE, SUMMIT/ Brown, Spice (Metallic)	ZY3 only	50	32					X	Doeskin/Carmine
WHITE, SUMMIT/ Brandywine (Metallic)	ZY3 only	50	95			X			Vermillion/Dark Red
WHITE, SUMMIT/ Quicksilver (Metallic)	ZY3 only	50	96			X			Vermillion/Silver

PRELIMINARY INFORMATION — SUBJECT TO CHANGE

C/K EXTENDED CAB PICKUP
INTERIOR AND EXTERIOR COLOR AVAILABILITY CHART
K3500 MODELS ONLY
WITH ZY3 AND ZY4 PAINT

PLEASE NOTE: Below are the interior trim color and exterior paint combinations recommended by Chevrolet/GMC. They are the only available interior and exterior combinations allowed.

TRIM LEVEL Seat Type	Decor	INTERIOR COLORS					
		Blue	Garnet	Saddle			
CHEYENNE/SIERRA SL Vinyl Bench Seat #Vinyl Split Bench Seat	STD	VDD1 VDD3	VRR1 VRR3	VSS1 VSS3			
SCOTTSDALE/SIERRA SLX Custom Vinyl Bench Seat #Custom Vinyl Split Bench Seat #Custom Vinyl Bucket Seat	Z62	XDD1 XDD3 XDD2	XRR1 XRR3 XRR2	XSS1 XSS3 XSS2			
SILVERADO/SIERRA SLE #Custom Cloth Split Bench Seat #Custom Vinyl Split Bench Seat #Custom Cloth Bucket Seat #Custom Vinyl Bucket Seat	YE9	LDD3 XDD3 LDD2 XDD2	LRR3 XRR3 LRR2 XRR2	LSS3 XSS3 LSS2 XSS2			
EXTERIOR COLORS w/ZY3, & ZY4 PAINT	Two-Tone Available	Color Code 1	Color Code 2	INTERIOR & EXTERIOR COMBINATIONS SHOWN ARE THE ONLY COMBINATIONS AVAILABLE			STRIPE COLOR
BLACK, SABLE (Metallic)/Gold, Adobe (Metallic)	ZY4 only	18	52	X		X	Gold/Black
BLACK, SABLE (Metallic)/Red, Flame	ZY4 only	18	70		X		Vermillion/Dark Red
BLUE, ICED (Metallic)/Blue, Pacific (Metallic)	ZY3 only	22	30	X			Light Blue/Dark Blue
BLUE, ICED (Metallic)/Quicksilver (Metallic)	ZY3 only	22	96	X			Light Blue/Dark Blue
BLUE, PACIFIC (Metallic)/Blue, Iced (Metallic)	ZY4 only	30	22	X			Light Blue/Dark Blue
BLUE, PACIFIC (Metallic)/Quicksilver (Metallic)	All	30	96	X			Vermillion/Silver
BLUE, PACIFIC (Metallic)/White, Summit	ZY4 only	30	50	X			Light Blue/Dark Blue
BLUE, PACIFIC (Metallic)/White, Summit	ZY4 only	30	50			X	Gold/Black
BRANDYWINE/Black, Sable (Metallic)	All	95	18		X		Vermillion/Dark Red
BRANDYWINE/Quicksilver (Metallic)	All	95	96		X		Vermillion/Silver
BRANDYWINE/White, Summit	ZY4 only	95	50		X		Vermillion/Dark Red
BROWN, SPICE (Metallic)/Gold, Adobe (Metallic)	ZY4 only	32	52			X	Doeskin/Carmine
GOLD, ADOBE (Metallic)/Black, Sable (Metallic)	ZY3 only	52	18			X	Doeskin/Carmine
QUICKSILVER (Metallic)/Blue, Iced (Metallic)	ZY4 only	96	22	X			Light Blue/Dark Blue
QUICKSILVER (Metallic)/Blue, Pacific (Metallic)	All	96	30	X			Light Blue/Dark Blue
QUICKSILVER (Metallic)/Brandywine (Metallic)	All	96	95		X		Vermillion/Silver
QUICKSILVER (Metallic)/Red, Flame	ZY4 only	96	70		X		Vermillion/Silver
RED, FLAME/Black, Sable	ZY3 only	70	18			X	Gold/Black
RED, FLAME/Black, Sable	ZY3 only	70	18		X		Vermillion/Dark Red
RED, FLAME/Quicksilver (Metallic)	ZY3 only	70	96		X		Vermillion/Dark Red
RED, FLAME/Quicksilver (Metallic)	ZY3 only	70	96			X	Vermillion/Silver
SANDSTONE (Metallic)/Brown, Spice (Metallic)	ZY3 only	58	32			X	Doeskin/Carmine
WHITE, SUMMIT/Blue, Pacific (Metallic)	ZY3 only	50	30	X			Light Blue/Dark Blue
WHITE, SUMMIT/Brandywine (Metallic)	ZY3 only	50	95		X		Vermillion/Dark Red
WHITE, SUMMIT/Brown, Spice (Metallic)	ZY3 only	50	32			X	Doeskin/Carmine
WHITE, SUMMIT/Quicksilver (Metallic)	ZY3 only	50	96		X		Vermillion/Silver

#Requires AM7 Folding Rear Seat.

PRELIMINARY INFORMATION—SUBJECT TO CHANGE

C/K PICKUP

SOLID AND TWO-TONE* EXTERIOR COLOR COMBINATIONS

The application of paint for solid and two-tone exterior color combinations is shown below.

Solid color paint (ZY1) is standard on all models. All painted areas of the cab, front end sheet metal, and box are the same color. Outlined block "Chevrolet/GMC" decal lettering is applied to the tailgate. (A bright trim plate with lettering is applied on Fleetside/Wideside models when the Silverado/Sierra SLX Model Option is ordered.)

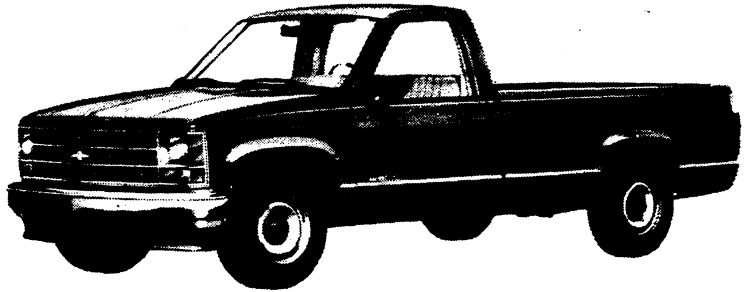

Conventional two-tone (ZY2) paint colors are available only on single rear wheel Fleetside/Wideside Pickup models. Color code 1 is applied to the areas above the lower styling crease line (including the cab roof). Color code 2 is applied to the areas below. Outlined block "Chevrolet/GMC" decal lettering is applied to the tailgate. (A bright trim plate with lettering is applied on Fleetside/Wideside models when the Silverado/Sierra SLX Model Option is ordered.)

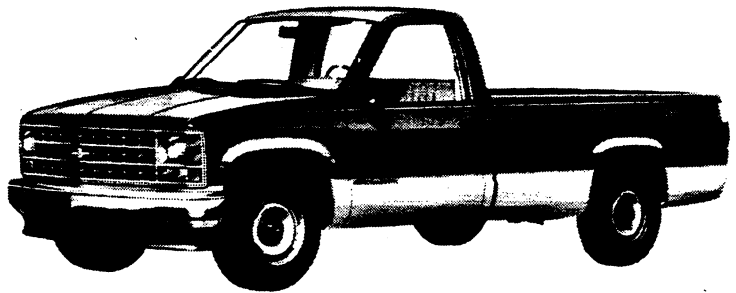

Special two-tone (ZY3) paint colors are available only on single rear wheel Fleetside/Wideside Pickup models and includes a multi-stripe decal applied over the paint break at the belt line. Color code 1 is applied to the areas above the decal (including the cab roof). Color code 2 is applied to the areas below. Outlined block "Chevrolet/GMC" decal lettering is applied to the tailgate. (A bright trim plate with lettering is applied on Fleetside/Wideside models when the Silverado/Sierra SLX Model Option is ordered.)

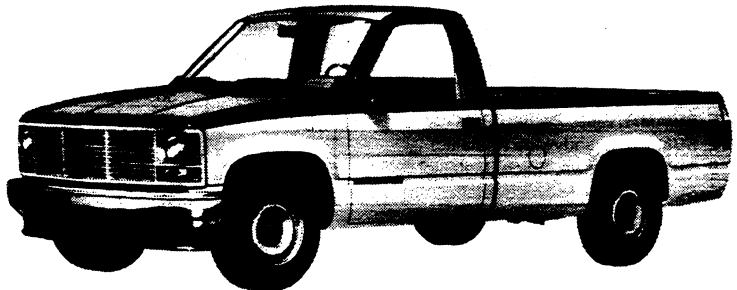

Deluxe two-tone (ZY4) paint colors are available only on single rear wheel Fleetside/Wideside Pickup models and include the belt line decal described in Special two-tone. The cab roof, hood and pickup box above the belt line decal, as well as the area below the lower styling crease line are painted Color Code 1. The areas between the decal and the lower crease line are painted Color Code 2. Outlined block "Chevrolet/GMC" decal lettering is applied to the tailgate. (A bright trim plate with lettering is applied on Fleetside/Wideside models when the Silverado/Sierra SLX Model Option is ordered.)

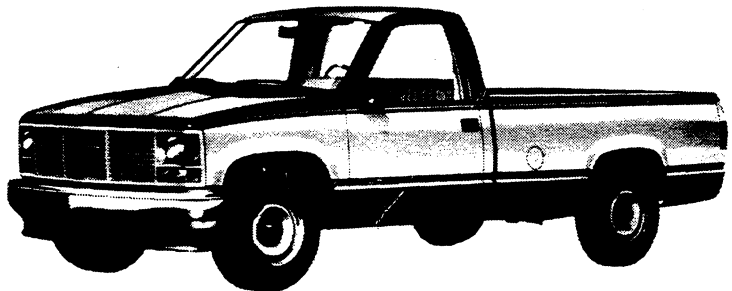

*Optional at extra cost

PRELIMINARY INFORMATION—SUBJECT TO CHANGE

C/K PICKUP

SILVERADO/SIERRA SLE MODEL OPTION—RPO YE9

This option includes all items in the Scottsdale/Sierra SLX model option plus the additions or substitutions listed below

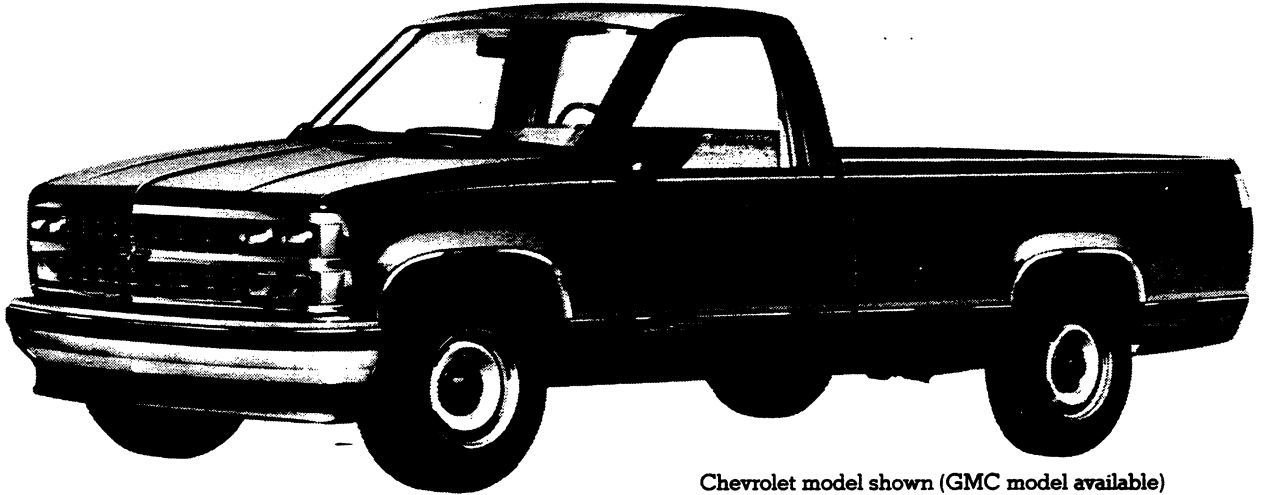

Chevrolet model shown (GMC model available)

EXTERIOR

- **Bright Appearance Items:**

- "Silverado/Sierra SLE" nameplates on upper rear side quarter panels
- Chrome-trimmed grille
- "Chevrolet/GMC" letters nameplate on tailgate applique panel (Fleetside/Wideside only)
- Bright applique panel fitted over central area of tailgate (Fleetside/Wideside only)
- Wheel-opening lip moldings (except K3 models) (Fleetside/Wideside models with single rear wheels only)

- **Bumper Rub Strips:** Black with bright trim
- **Cab-to-Fender Insulators:** Gasoline models only
- **Hood Insulator**
- **Horn:** Additional, electric, high note
- **Moldings:** Black body side with bright trim
- **Special Headlamps:** Halogen, rectangular; dual RH and LH

INTERIOR

- **Cab-to-Fender Insulators**
- **Cigarette Lighter:** In ashtray
- **Cowl Panel Trim:** Color-keyed carpet on cowl side panels with insulator
- **Door Trim Panels:** Two-tone soft vinyl over plastic with integral armrests, map pocket, door closing assist straps, and Silverado/SLE emblems
- **Floor Covering:** Color-keyed carpeting and sill plates
- **Hood Insulator**
- **Insulation:** On cab back panel
- **Seats:**

Regular Cabs—Choice of Custom Vinyl or Custom Cloth bench seat. Also available at extra cost: Custom vinyl or custom cloth front bucket seats

Extended Cabs—Choice of Custom Vinyl or Custom Cloth split front bench seat with RH easy-entry feature. Also available at extra cost: 1) Custom vinyl or custom cloth front bucket seats with RH easy-entry feature; and 2) Matching Custom Vinyl or Custom Cloth rear folding bench seat.

See Interior and Exterior Color Selection Chart for color and trim availability

- **Steering Wheel:** Custom 4-spoke
- **Sunshades:** RH & LH cloth covered with storage strap on LH unit
- **Trim Panels:** Color-keyed carpet on cab back panel
- **Visor Mirror:** On RH sun visor

PRELIMINARY INFORMATION—SUBJECT TO CHANGE